



CS5T3-24B-3S-Tx-C

1.25Gbps Tx1550nm/Rx1310nm SMF 15km BiDi 1x9 Optical Transceiver

Data Sheet



DESCRIPTION

The CS5T3-24B-3S-Tx-C is a 1.25Gbps bi-directional optical transceiver designed for single-fiber communication over single mode fiber (SMF). Operating at TX 1550nm / RX 1310nm, this device enables efficient data transmission over a single strand of fiber and maintains reliable performance up to 15 kilometers.

FEATURES

- Compliant with IEEE 802.3 Gigabit Ethernet standard
- Industry standard 1×9 footprint
- SC connector
- Single power supply 3.3V
- Differential inputs and outputs
- Compatible with solder and aqueous wash processes
- Class 1 laser product compliant with EN 60825-1

APPLICATIONS

- Single mode core fiber backbone links up to 15km
- Gigabit Ethernet

ORDERING INFORMATION

PART NUMBER	TX	RX	INPUT/OUTPUT	SIGNAL DETECT	TEMPERATURE	LD TYPE
CS5T3-24B-3S-TC-C	1550nm	1310nm	AC/AC	LVTTL	0°C to 70°C	DFB
CS5T3-24B-3S-TI-C	1550nm	1310nm	AC/AC	LVTTL	-40°C to 85°C	DFB

ABSOLUTE MAXIMUM RATINGS

PARAMETER	SYMBOL	MIN	MAX	UNIT	NOTES
Storage Temperature	T _s	-40	85	°C	
Supply Voltage	V _{CC}	-0.5	4.0	V	
Input Voltage	V _{IN}	-0.5	V _{CC}	V	
Soldering Temperature	T _{SOLD}	-	260	°C	10 seconds on leads

RECOMMENDED OPERATING CONDITIONS

PARAMETER	SYMBOL	MIN	MAX	UNIT	NOTES
Case Operating Temperature	T _C	0	70	°C	
		-40	85		
Supply Voltage	V _{CC}	3.1	3.5	V	
Supply Current	I _{TX} + I _{RX}	-	300	mA	

TRANSMITTER ELECTRO-OPTICAL CHARACTERISTICS

PARAMETER	SYMBOL	MIN	TYP.	MAX	UNIT	NOTES
Data Rate	B	-	1250	1300	Mbps	
Output Optical Power 9/125um fiber	P _{out}	-9	-	-3	dBm	Average
Extinction Ratio	ER	9	-	-	dB	
Center Wavelength	λ _C	1530	1550	1570	nm	
Spectral Width (-20dB)	Δλ	-	-	1	nm	
Side Mode Suppression Ratio	SMSR	30	-	-	dB	
Rise/Fall Time, 20%~80%	T _{r,f}	-	-	260	ps	
Output Eye		Compliant with IEEE802.3				
Transmitter Data Input Differential Voltage	V _{DIFF}	0.3	-	2.0	V	

RECEIVER ELECTRO-OPTICAL CHARACTERISTICS

PARAMETER	SYMBOL	MIN	TYP.	MAX	UNIT	NOTES
Data Rate	B	-	1250	1300	Mbps	
Optical Input Power-Maximum	P _{IN}	-3	-	-	dBm	BER<10 ⁻¹²
Optical Input Power-Minimum (Sensitivity)	P _{IN}	-	-	-21	dBm	BER<10 ⁻¹²
Operating Center Wavelength	λ _C	1260	-	1360	nm	
Return Loss	RL	-	-	-14	dB	λ=1260~1360nm
Signal Detect-Asserted	P _A	-	-	-21	dBm	Average
Signal Detect-Deasserted	P _D	-35	-	-	dBm	Average
Signal Detect-Hysteresis	P _A -P _D	0.5	-	-	dB	
Signal Detect Voltage (LVTTTL)-High	V _{OH}	V _{CC} -0.8	-	V _{CC}	V	
Signal Detect Voltage (LVTTTL)-Low	V _{OL}	0	-	0.5	V	
Crosstalk	CRT	-	-	-45	dB	
Data Output Rise, Fall Time (20~80%)	T _{r,f}	-	-	0.35	ns	
Data Output Differential Voltage	V _{DIFF}	0.6	-	1.2	V	



BLOCK DIAGRAM OF TRANSCEIVER

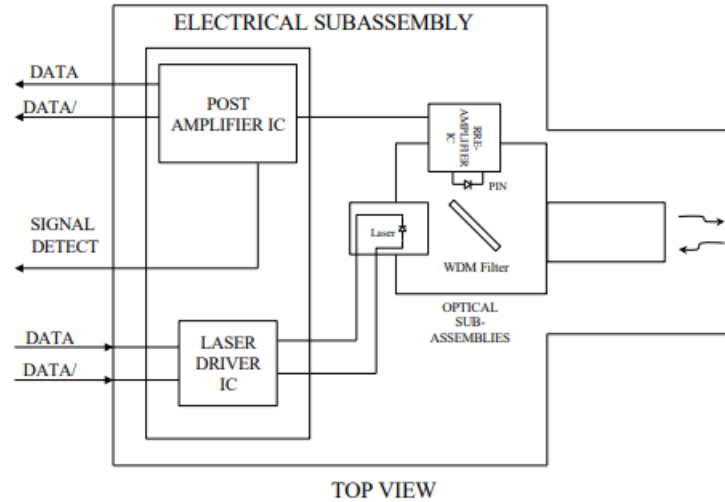

Transmitter and Receiver Optical Sub-Assembly Section - A 1550 nm InGaAsP laser and an InGaAs PIN photodiode integrate with an WDM filter to form a bi-directional single fiber optical subassembly (OSA). The laser of OSA is driven by a LD driver IC which converts differential input LVPECL logic signals into an analog laser driving current. The photodiode of OSA is connected to a circuit providing post-amplification quantization, and optical signal detection.

Receiver Signal Detect - Signal Detect is a basic fiber failure indicator. This is a single-ended LVTTTL output. As the input optical power is decreased, Signal Detect will switch from high to low (deassert point) somewhere between sensitivity and the no light input level. As the input optical power is increased from very low levels, Signal Detect will switch back from low to high (assert point).

CONNECTION DIAGRAM

Pin-Out

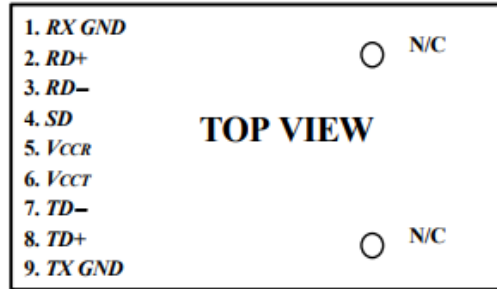

PIN	SYMBOL	DESCRIPTION
1	<i>RX GND</i>	Receiver Signal Ground. Directly connect this pin to the receiver ground plane.
2	<i>RD+</i>	Receiver Data Output Internally ac coupled. Terminate this differential data output with a 50Ω line and a 50Ω load at the follow-on device (See recommended circuit schematic)
3	<i>RD-</i>	Receiver Data Output-Bar Internally ac coupled. Terminate this differential data output with a 50Ω line and a 50Ω load at the follow-on device (See recommended circuit schematic)
4	<i>SD</i>	Signal Detect. Normal optical input levels to the receiver result in a logic “1” output, <i>V_{OH}</i> , asserted. Low input optical levels to the receiver result in a fault condition indicated by a logic “0” output <i>V_{OL}</i> , deasserted Signal Detect is a LVTTTL output.
5	<i>V_{CCR}</i>	Receiver Power Supply. Provide +3.3 Vdc via the recommended receiver power supply filter circuit. Locate the power supply filter circuit as close as possible to the <i>V_{CCR}</i> pin.
6	<i>V_{CCT}</i>	Transmitter Power Supply. Provide +3.3 Vdc via the recommended transmitter power supply filter circuit. Locate the power supply filter circuit as close as possible to the <i>V_{CCT}</i> pin.
7	<i>TD-</i>	Transmitter Data In-Bar. Internally ac coupled. The input stage is internally biased and 50Ω terminated. (See recommended circuit schematic)
8	<i>TD+</i>	Transmitter Data In. Internally ac coupled. The input stage is internally biased and 50Ω terminated. (See recommended circuit schematic)
9	<i>TX GND</i>	Transmitter Signal Ground. Directly connect this pin to the transmitter signal ground plane. Directly connect this pin to the transmitter ground plane.



RECOMMENDED CIRCUIT SCHEMATIC

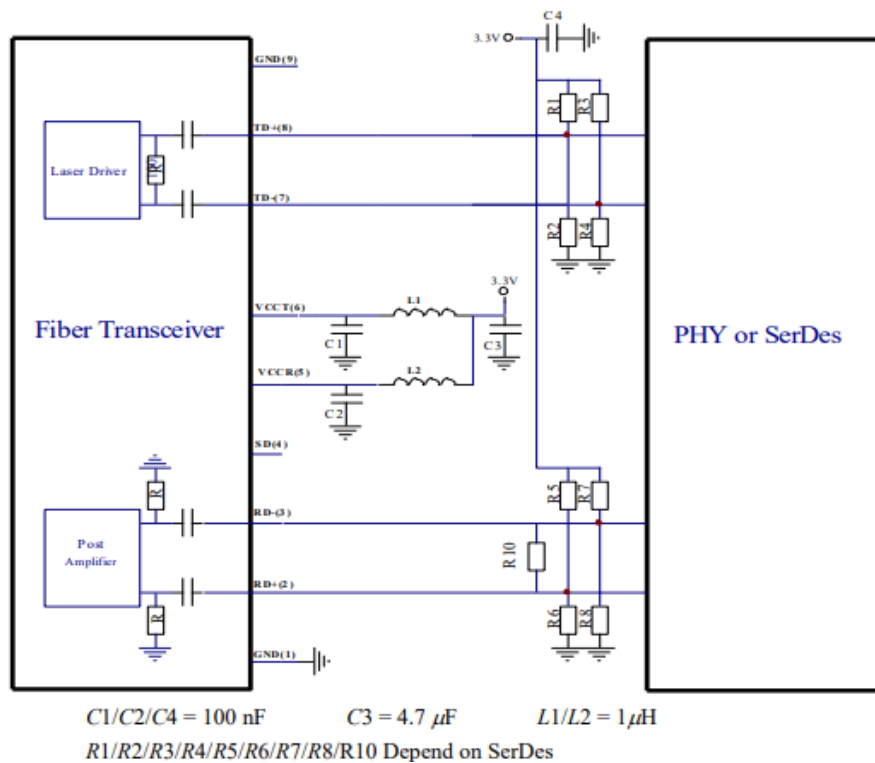

In order to get proper functionality, a recommended circuit is provided in above recommended circuit schematic. When designing the circuit interface, there are a few fundamental guidelines to follow.

- (1) The differential data lines should be treated as 50 Ω Micro strip or strip line transmission lines. This will help to minimize the parasitic inductance and capacitance effects. Locate termination at the received signal end of the transmission line. The length of these lines should be kept short and of equal length.
- (2) For the high speed signal lines, differential signals should be used, not single-ended signals, and these differential signals need to be loaded symmetrically to prevent unbalanced currents which will cause distortion in the signal.
- (3) Multi layer plane PCB is best for distribution of V_{CC} , returning ground currents, forming transmission lines and shielding, Also, it is important to suppress noise from influencing the fiber-optic transceiver performance, especially the receiver circuit.
- (4) A separate proper power supply filter circuits shown in Figure for the transmitter and receiver sections. These filter circuits suppress V_{CC} noise over a broad frequency range, this prevents receiver sensitivity degradation due to V_{CC} noise.
- (5) Surface-mount components are recommended. Use ceramic bypass capacitors for the 0.1 μF capacitors and a surface-mount coil inductor for 1 μH inductor. Ferrite beads can be used to replace the coil inductors when using quieter V_{CC} supplies, but a coil inductor is recommended over a ferrite bead. All power supply components need to be placed physically next to the V_{CC} pins of the receiver and transmitter.
- (6) Use a good, uniform ground plane with a minimum number of holes to provide a low-inductance ground current return for the power supply currents.

RECOMMENDED BOARD LAYOUT HOLE PATTERN

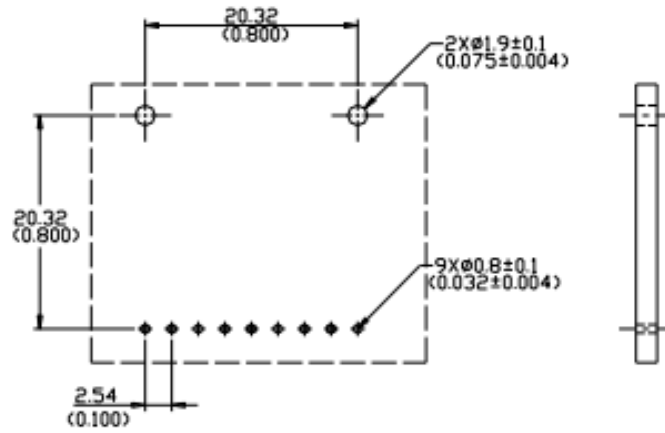

Unit : mm(inches)

DRAWING DIMENSIONS

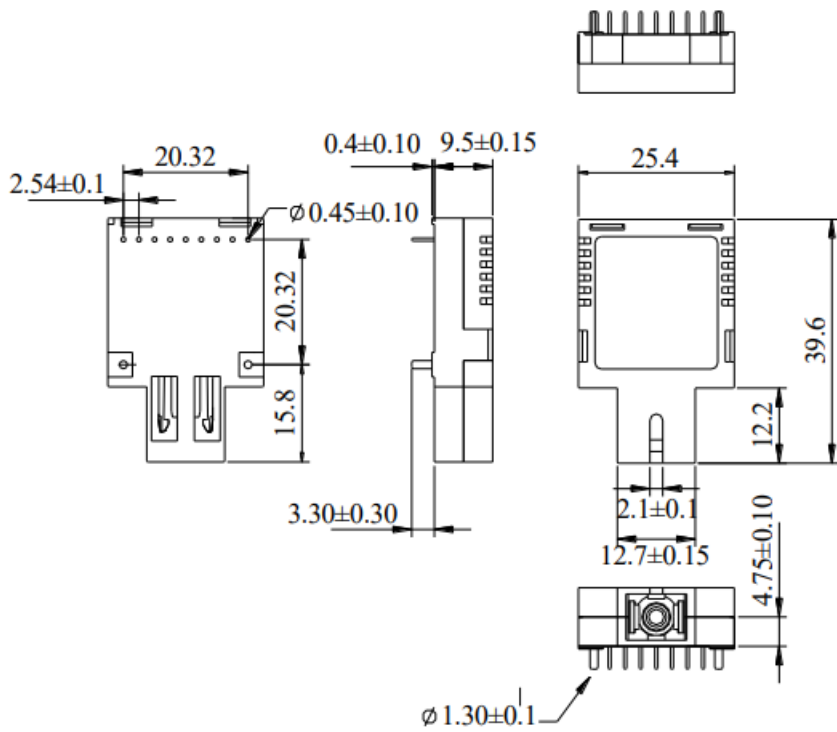

ALL DIMENSIONS ARE ± 0.20 mm UNLESS OTHERWISE SPECIFIED

Unit : mm



ADDITIONAL NOTES

- Avoid eye or skin exposure to laser radiation.
- The device is sensitive to electro-static discharge (ESD). The device should be handled with ESD proof tools. To assemble the device on PCB, proper grounding is required to prevent ESD.
- Specifications are subject to change without notice.

