



635nm 30mW Laser Diode, TO-18 (ø5.6mm) Package LD635A30C14

Data Sheet

Features

- 635nm AlGaInP Visible Laser Diode
- Optical output power: 30mW CW
- Operating temperature: +40°C
- High visibility
- High ESD level
- Package: TO-18, ø5.6mm

Applications

- Industrial laser markers
- Survey and engineering instruments
- High visibility LD display
- Lighting show

Specifications

ABSOLUTE MAXIMUM RATINGS				
PARAMETER	SYMBOL	CONDITION	RATING	UNIT
Light output power	P _O	CW	35	mW
Reverse voltage (LD)	V _{RL}	-	2	V
Reverse voltage (PD)	V _{RD}	-	30	V
Forward current (PD)	I _{FD}	-	10	mA
Case temperature	T _C	-	-10 to +40	°C
Storage temperature	T _S	-	-40 to +85	°C

ELECTRICAL AND OPTICAL CHARACTERISTICS (T _C = 25 °C)						
PARAMETER	SYMBOL	MIN.	TYP.	MAX.	UNIT	CONDITIONS
Peak wavelength	λ	630	640	645	nm	P _O = 30mW
Threshold current	I _{th}	-	50	70	mA	
Operating current	I _{op}	-	100	120	mA	P _O = 30mW
Operating voltage	V _{op}	-	2.3	2.7	V	P _O = 30mW
Differential efficiency	η	0.3	0.6	1.2	mW/mA	P _O = 25-30mW
Monitor current	I _m	0.1	0.25	0.5	mA	P _O = 30mW, V _{RD} = 5V
Parallel divergence angle	Θ	5	8	12	deg	P _O = 30mW
Perpendicular divergence angle	Θ _⊥	25	33	38	deg	
Parallel FFP deviation angle	ΔΘ	-3	0	+3	deg	
Perpendicular FFP deviation angle	ΔΘ _⊥	-3	0	+3	deg	
Emission point accuracy	Δx Δy Δz	-80	0	+80	um	

Typical Characteristics

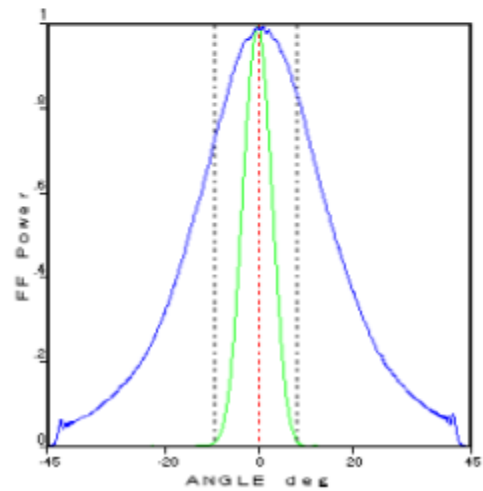
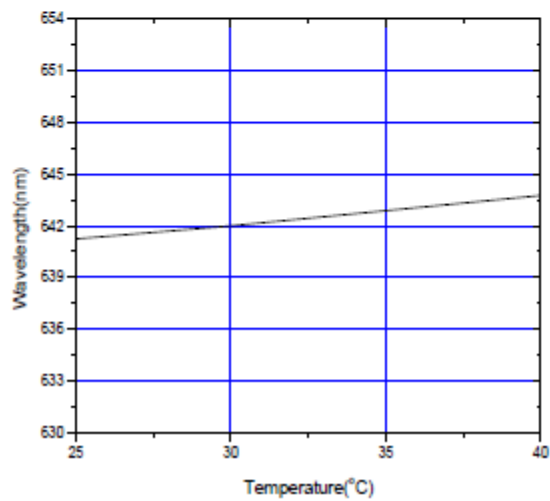
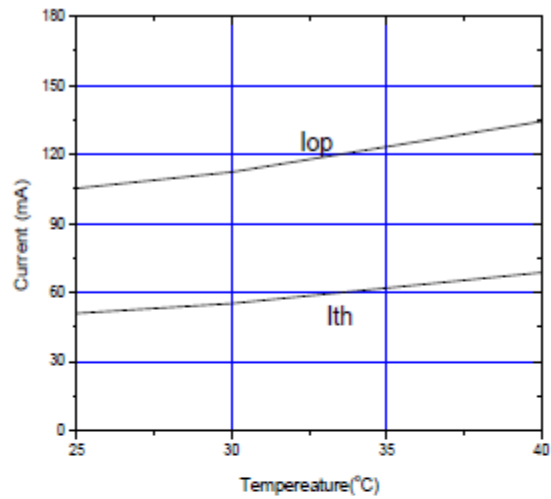
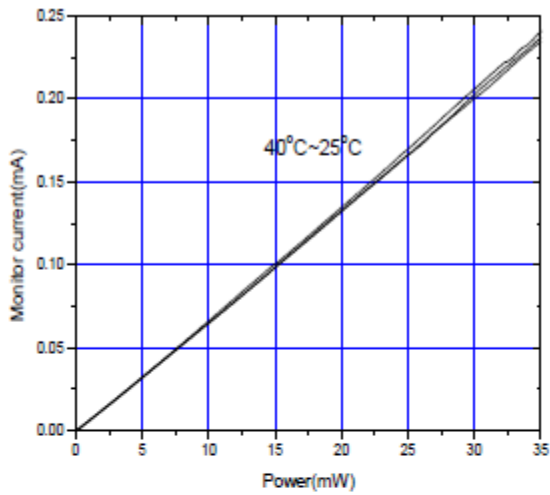
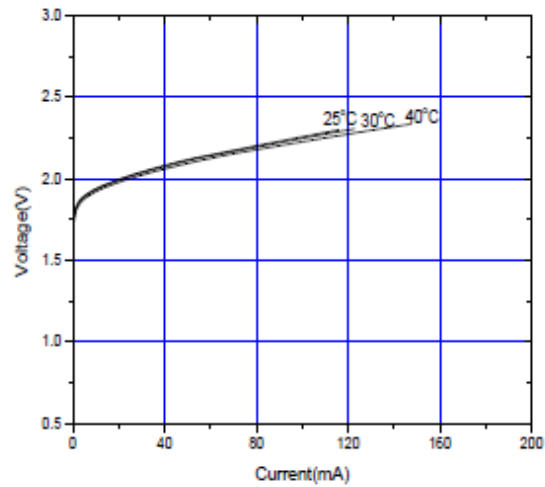
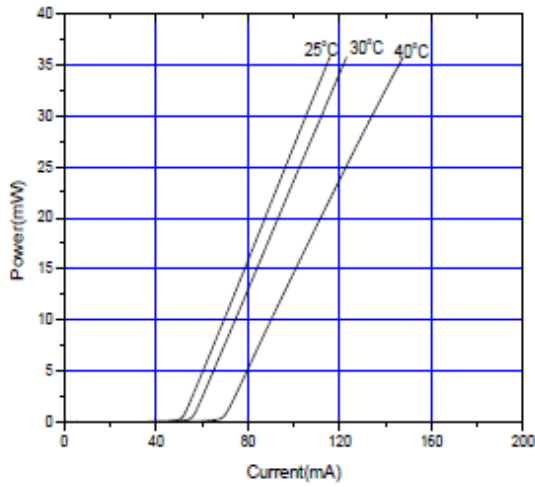

Mechanical Outline (unit: mm)

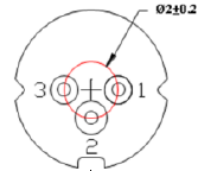
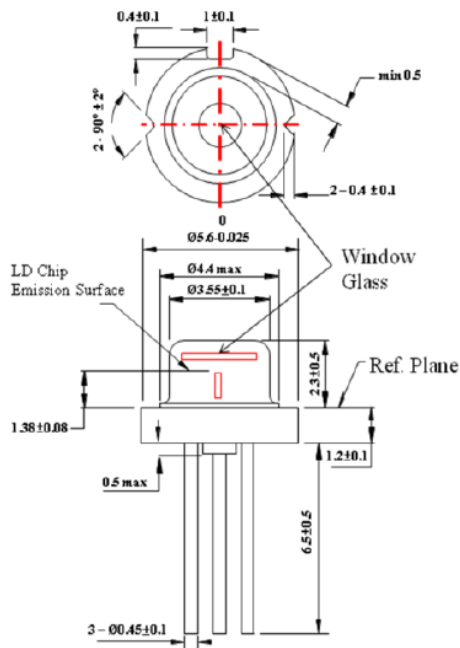

PIN CONFIGURATION

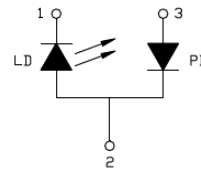

Additional Notes

- Do not operate the device above maximum ratings. Doing so may cause unexpected and permanent damage to the device.
- Take precautions to avoid electrostatic discharge and/or momentary power spikes. A change in the characteristics of the laser or premature failure may result.
- Proper heat sinking of the device assures stability and lifetime. Always ensure that maximum operating temperatures are not exceeded.
- Observing visible or invisible laser beams with human eye directly, or indirectly, can cause permanent damage. Use a camera to observe the laser.
- No laser device should be used in any application or situation where life or property is at risk in the event of device failure.
- Specifications are subject to change without notice. Ensure that you have the latest specification by contacting us prior to purchase or use of the product.