



635nm 20mW Laser Diode, TO-18 (ø5.6mm) Package LD635A20C14

Data Sheet

Features

- 635nm AlGaInP Visible Laser Diode
- Optical output power: 20mW CW
- Operating temperature: 40°C
- High visibility
- Small perpendicular divergence angle
- Package: TO-18, ø5.6mm

Applications

- Industrial laser markers
- Survey and engineering instruments
- High visibility LD display

Specifications

ABSOLUTE MAXIMUM RATINGS				
PARAMETER	SYMBOL	CONDITION	RATING	UNIT
Light output power	P_O	CW	30	mW
Reverse voltage (LD)	V_{RL}	-	2	V
Reverse voltage (PD)	V_{RD}	-	30	V
Forward current (PD)	I_{FD}	-	10	mA
Case temperature	T_C	-	-10 to +40	°C
Storage temperature	T_S	-	-40 to +85	°C

ELECTRICAL AND OPTICAL CHARACTERISTICS (TC = 25 °C)						
PARAMETER	SYMBOL	MIN.	TYP.	MAX.	UNIT	CONDITIONS
Peak wavelength	λ	630	639	645	nm	$P_O = 20\text{mW}$
Threshold current	I_{th}	-	40	50	mA	
Operating current	I_{op}	-	75	85	mA	$P_O = 20\text{mW}$
Operating voltage	V_{op}	-	2.2	2.7	V	$P_O = 20\text{mW}$
Differential efficiency	η	0.4	0.6	0.8	mW/mA	$P_O = 10\text{-}20\text{mW}$
Monitor current	I_m	0.05	0.2	0.5	mA	$P_O = 20\text{mW}$, $V_{RD} = 5\text{V}$
Parallel divergence angle	$\Theta_{//}$	6	8	11	deg	$P_O = 20\text{mW}$
Perpendicular divergence angle	Θ_{\perp}	28	33	36	deg	
Parallel FFP deviation angle	$\Delta \Theta_{//}$	-3	0	+3	deg	
Perpendicular FFP deviation angle	$\Delta \Theta_{\perp}$	-3	0	+3	deg	
Emission point accuracy	$\Delta x \Delta y \Delta z$	-80	0	+80	um	

Typical Characteristics

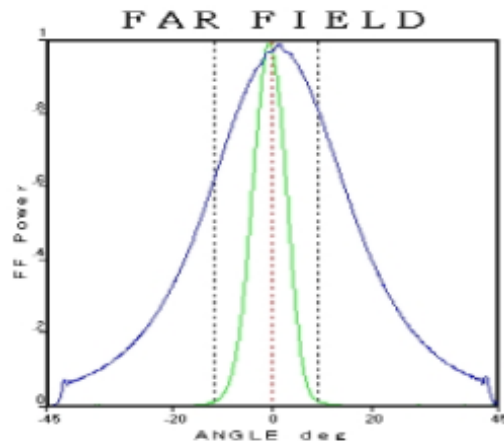
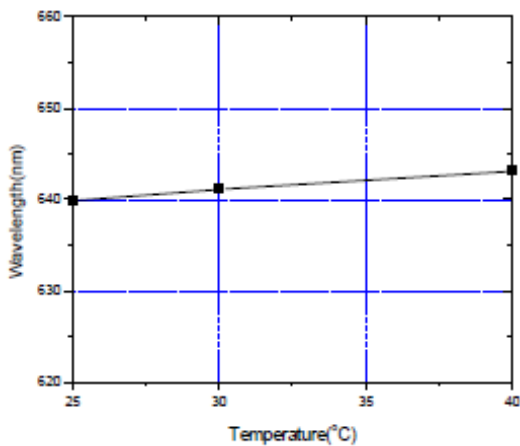
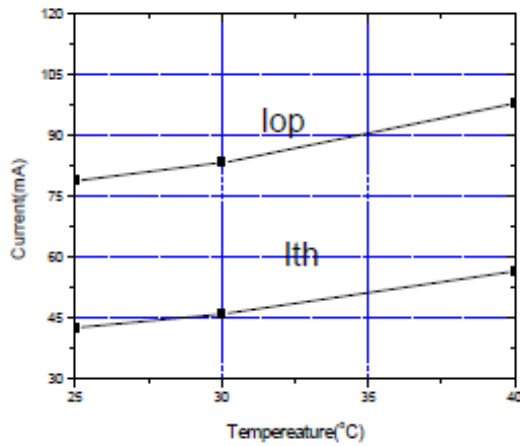
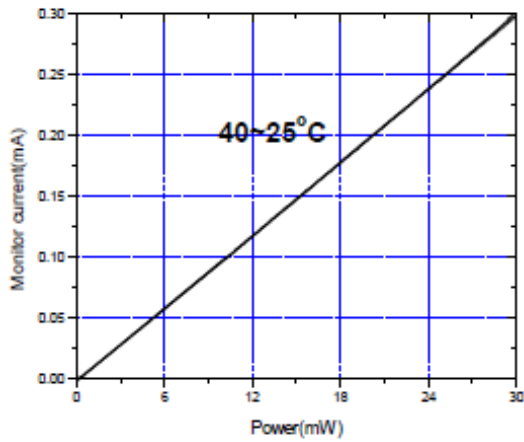
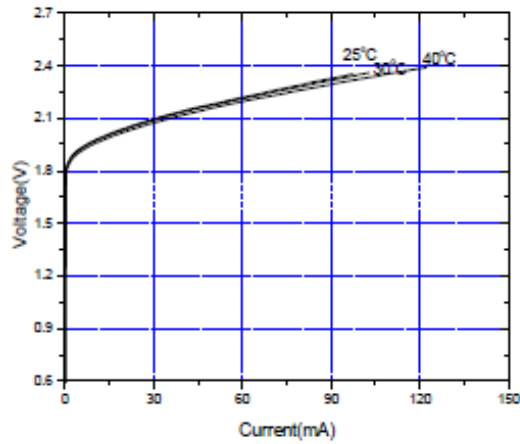
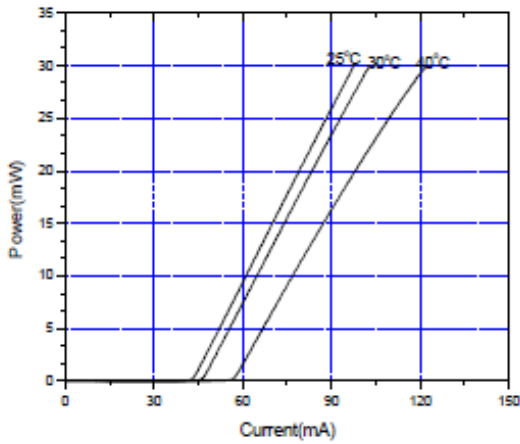

Mechanical Outline (unit: mm)

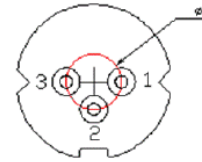
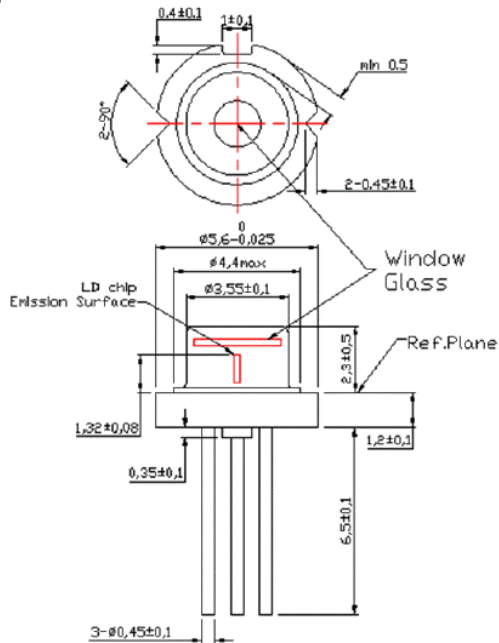

PIN CONFIGURATION

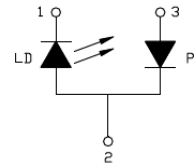

Additional Notes

- Do not operate the device above maximum ratings. Doing so may cause unexpected and permanent damage to the device.
- Take precautions to avoid electrostatic discharge and/or momentary power spikes. A change in the characteristics of the laser or premature failure may result.
- Proper heat sinking of the device assures stability and lifetime. Always ensure that maximum operating temperatures are not exceeded.
- Observing visible or invisible laser beams with human eye directly, or indirectly, can cause permanent damage. Use a camera to observe the laser.
- No laser device should be used in any application or situation where life or property is at risk in the event of device failure.
- Specifications are subject to change without notice. Ensure that you have the latest specification by contacting us prior to purchase or use of the product.