



CW Diode Laser System

DLSD Series



Overview

The DLSD series is a family of UV and visible diode lasers that can deliver up to 4000 mW output power. The laser series is available in fourteen wavelengths and features high power, compact design, long operating lifetime, easy operation, and FDA-compliant system with driver. The DLSD 375/488nm series laser is widely used in medical imaging, flow cytometry, DNA sequencing, and many other applications. The DLSD 445/447/450/635/637/640/642nm series laser is used in measurement, communication, and spectrum analysis. The DLSD 454/460/462/465/470nm series laser is used in laser projection, stage lighting, biomedical applications, metrology, etc.

Features

- UV-Visible wavelengths
- CW operating mode
- Optical output power 100mW to 4000mW
- Ultra-compact design
- FDA compliant

Applications

- Medical imaging
- Flow cytometry
- DNA sequencing
- Measurement
- Spectrum analysis
- Communication
- Laser projection
- Stage lighting
- Biomedical application
- Metrology

375-454 nm Specifications

Parameter	DLSD375	DLSD445		DLSD447		DLSD450		DLSD454		
Wavelength	375 nm	445 nm		447 nm		450 nm		454 nm		
Wavelength tolerance	±5 nm	±5 nm		±5 nm		±5 nm		±5 nm		
Output power	>500 mW, >800 mW	>3500 mW, >4000 mW		>3500 mW, >4000 mW		>3500 mW, >4000 mW		>2000 mW, >3000 mW		
Operating mode	CW	CW		CW		CW		CW		
Power stability (rms, over 4 hours)	<1%	<1%		<1%		<1%		<2%, <1%		
Polarization direction	Horizontal + Vertical	Horizontal/Vertical	Horizontal + Vertical	Horizontal/Vertical	Horizontal + Vertical	Horizontal/Vertical	Horizontal + Vertical	Horizontal/Vertical	Horizontal + Vertical	
Beam diameter at aperture (1/e ²)	~4.0x4.5 mm	~4.7x2.7 mm	~2.7x2.7 mm	~4.7x2.7 mm	~2.7x2.7 mm	~4.7x2.7 mm	~2.7x2.7 mm	~4.7x2.7 mm	~2.7x2.7 mm	
Beam divergence, full angle	~1.5 mrad	~1.4x0.2 mrad		~1.4x0.2 mrad		~1.4x0.2 mrad		~1.4x0.2 mrad		
Warm-up time	<5 min	<5 min		<5 min		<5 min		<5 min		
Operating temperature	10-35°C	10-35°C		10-35°C		10-35°C		10-35°C		
Modulation option	TTL/Analog: 1Hz-1kHz, 1kHz-10kHz, 10kHz-30kHz									
Expected lifetime	10,000 hours									
Warranty period	10 months									

Remarks:

- Specifications of the CW laser is based on the laser performance at full power output after the specified warmup period. The stability of output power may change when output power is adjusted at a different power level.
- Specifications are subject to change without notice.

460-488 nm Specifications

Parameter	DLSD460		DLSD462		DLSD465		DLSD470		DLSD488	
Wavelength	460 nm		462 nm		465 nm		470 nm		488 nm	
Wavelength tolerance	±5 nm		±5 nm		±5 nm		±10 nm		±5 nm	
Output power	>2000 mW, >3000 mW		>2000 mW, >3000 mW		>2000 mW, >3000 mW		>2000 mW, >3000 mW		>100 mW	
Operating mode	CW		CW		CW		CW		CW	
Power stability (rms, over 4 hours)	<2%, <1%		<2%, <1%		<2%, <1%		<2%, <1%		<2%, <1%	
Polarization direction	Horizontal/Vertical	Horizontal + Vertical	Horizontal/Vertical	Horizontal + Vertical	Horizontal/Vertical	Horizontal + Vertical	Horizontal/Vertical	Horizontal + Vertical	Horizontal/Vertical	Horizontal + Vertical
Beam diameter at aperture (1/e ²)	~4.7x2.7 mm	~2.7x2.7 mm	~4.7x2.7 mm	~2.7x2.7 mm	~4.7x2.7 mm	~2.7x2.7 mm	~4.7x2.7 mm	~2.7x2.7 mm	~2.0x3.5 mm	~1.0x3.5 mm
Beam divergence, full angle	~1.4x0.2 mrad		~1.4x0.2 mrad		~1.4x0.2 mrad		~1.4x0.2 mrad		<1.0x0.6 mrad	
Warm-up time	<5 min		<5 min		<5 min		<5 min		<5 min	
Operating temperature	10-35°C		10-35°C		10-35°C		10-35°C		10-35°C	
Modulation option	TTL/Analog: 1Hz-1kHz, 1kHz-10kHz, 10kHz-30kHz									
Expected lifetime	10,000 hours									
Warranty period	10 months									

Remarks:

- Specifications of the CW laser is based on the laser performance at full power output after the specified warmup period. The stability of output power may change when output power is adjusted at a different power level.
- Specifications are subject to change without notice.

635-642 nm Specifications

Parameter	DLSD635	DLSD637		DLSD640		DLSD642	
Wavelength	635 nm	637 nm		640 nm		642 nm	
Wavelength tolerance	±10 nm	±5 nm		±5 nm		±5 nm	
Output power	>1000 mW	>300 mW, >500 mW		>300 mW, >500 mW		>300 mW, >500 mW	
Operating mode	CW	CW		CW		CW	
Power stability (rms, over 4 hours)	<2%, <1%	<2%, <1%		<2%, <1%		<2%, <1%	
Polarization direction	Horizontal + Vertical	Horizontal/ Vertical	Horizontal + Vertical	Horizontal/ Vertical	Horizontal + Vertical	Horizontal/ Vertical	Horizontal + Vertical
Beam diameter at aperture (1/e ²)	5.0x3.8 mm	~3.5x1.8 mm	~2.8x2.3 mm	~3.5x1.8 mm	~2.8x2.3 mm	~3.5x1.8 mm	~2.8x2.3 mm
Beam divergence, full angle	<1.6x0.2 mrad	<1.0 mrad		<1.0 mrad		<1.0 mrad	
Warm-up time	<5 min	<5 min		<5 min		<5 min	
Operating temperature	10-35°C	10-35°C		10-35°C		10-35°C	
Modulation option	TTL/Analog: 1Hz-1kHz, 1kHz-10kHz, 10kHz-30kHz						
Expected lifetime	10,000 hours						
Warranty period	10 months						

Remarks:

- Specifications of the CW laser is based on the laser performance at full power output after the specified warmup period. The stability of output power may change when output power is adjusted at a different power level.
- Specifications are subject to change without notice.

DLSD Series Laser Head Dimensions

Unit: mm

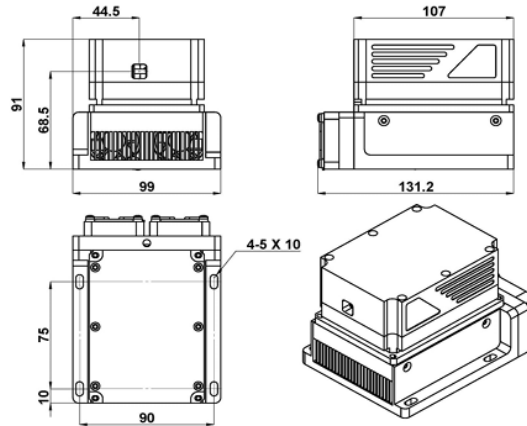

Parameter	DLSD Series
Dimensions	131.2(L)×99(W) ×91(H) mm ³
Weight	1.6 kg
Beam height from base plate	68.5 mm

DLSD Series Power Supply Dimensions

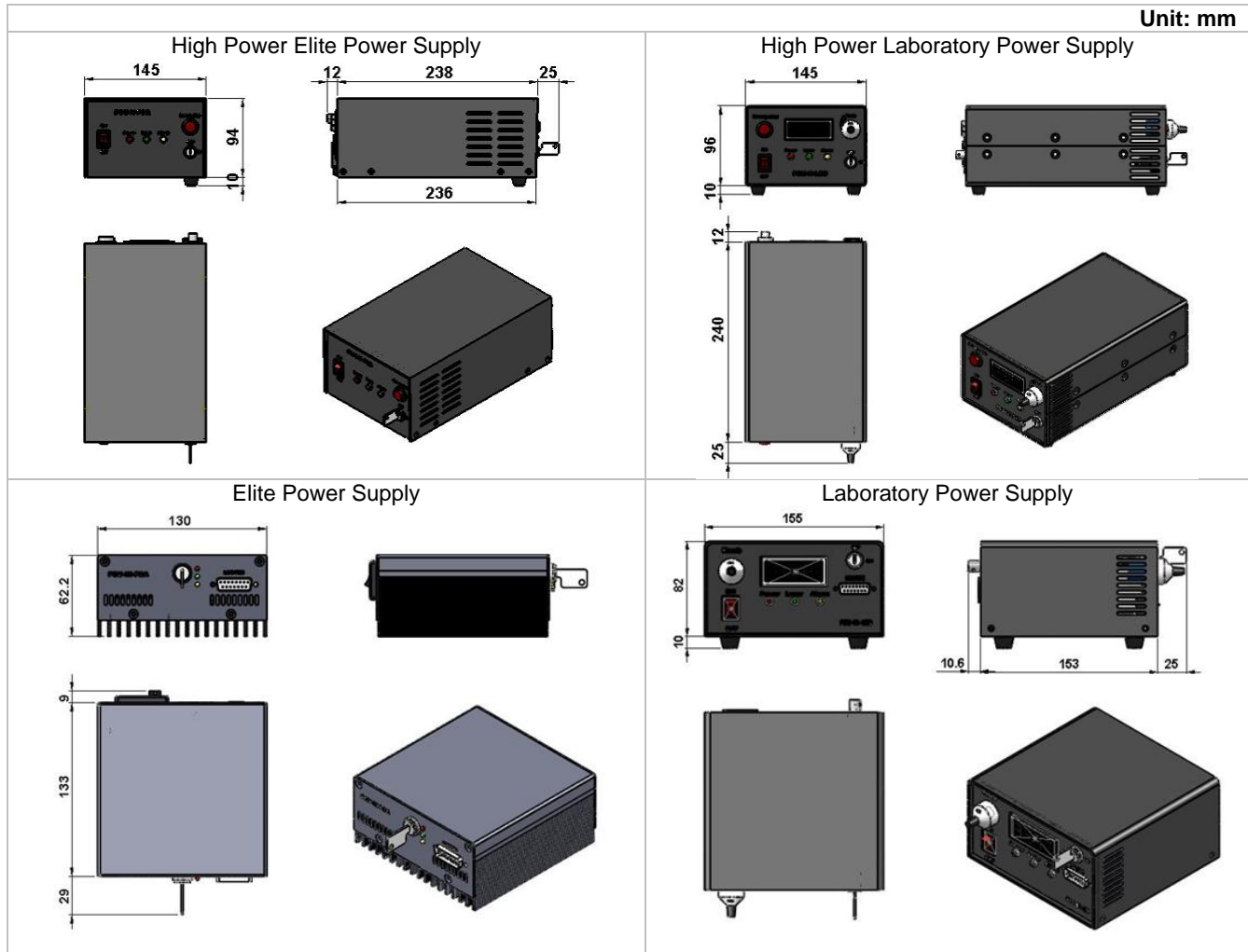

Parameter	High Power Elite Power Supply (375, 445, 447, 450, 454, 460, 462, 465, 470, 488 nm)	High Power Laboratory Power Supply (375, 445, 447, 450, 454, 460, 462, 465, 470, 488 nm)
Dimensions	275(L) x145(W) x104(H) mm ³	277(L) x145(W) x106(H) mm ³
Weight	2.1 kg	2.3 kg
Input voltage	85-264VAC	85-264VAC
Feature	Standard	Adjustable power
Parameter	Elite Power Supply (635, 637, 640, 642 nm)	High Power Laboratory Power Supply (635, 637, 640, 642 nm)
Dimensions	171(L) x130(W) x62.2(H) mm ³	188.6(L) x155(W) x92(H) mm ³
Weight	1.2 kg	1.5 kg
Input voltage	85-264VAC	85-264VAC
Feature	Standard	Adjustable power

Ordering Information

For more information, please contact Lasermate directly at sales@lasermate.com.

Part Number Configuration DLSD[1][2][3][4][5][6]						
DLSD = Laser Model Series	[1] = Wavelength	[2] = Output Power	[3] = Power Supply	[4] = Power Stability	[5] = Modulation	[6] = Polarization Direction
		100= >100mW 200= >200mW 300= >300mW 500= >500mW 1W= >1000mW 2W= >2000mW 3W= >3000mW 3H= >3500mW 4W= >4000mW	H=High Power Elite Power Supply M=High Power Laboratory Power Supply E=Elite Power Supply L=Laboratory Power Supply	2=<2% D=<1%	0=None T1=TTL 1Hz-1kHz T2=TTL 1kHz-10kHz T3=TTL 10kHz-30kHz A1=Analog 1Hz-1kHz A2=Analog 1kHz-10kHz A3=Analog 10kHz-30kHz	H= Horizontal V = Vertical M= Horizontal + Vertical

Note: The above specifications are subject to change without notice.