

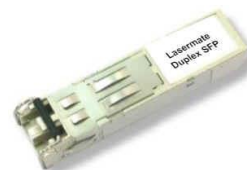

# 155Mbps 1310nm MMF 2km SFP Optical Transceiver with Duplex LC Connector

CM13L-03F-3S-Tx-L



## DESCRIPTION

The CM13L-03F-3S-Tx-L duplex SFP (Small Form Pluggable) optical transceivers are high performance, cost effective optical transceiver modules for serial optical data communications application specified for a data rate of 155 Mb/s. The SFP transceiver module provides 2km transmission distance over multi-mode fiber at nominal wavelength of 1310nm. The optical transceiver is RoHS compliant.

## FEATURES

- RoHS compliant
- Compliant with Fast ethernet standard
- Compatible with SONET/SDH application
- Industry standard small form pluggable (SFP) package
- Hot pluggable
- Single power supply 3.3V
- Duplex LC optical connection
- Differential LVPECL inputs and outputs
- TTL signal detect indicator
- Class 1 laser product compliant with EN 60825-1
- Input/Output: AC/AC
- Up to 2km over multimode fiber

## APPLICATIONS

- Distributed multi-processing
- Switch to switch interface
- High speed I/O for file server
- Bus extension application
- Channel extender, data storage
- Fast Ethernet / OC3

## PRODUCT OVERVIEW

PART NUMBER	OPERATING TEMPERATURE
CM13L-03F-3S-TC-L	-10°C to 70°C
CM13L-03F-3S-TI-L	-40°C to 85°C

**ABSOLUTE MAXIMUM RATINGS**

PARAMETER	SYMBOL	MIN	MAX	UNIT
Storage Temperature	T <sub>S</sub>	-40	85	°C
Supply Voltage	V <sub>CC</sub>	-0.5	4.0	V
Input Voltage	V <sub>IN</sub>	-0.5	V <sub>CC</sub>	V
Output Current	I <sub>O</sub>	-	50	mA
Operating Current	I <sub>OP</sub>	-	400	mA

**RECOMMENDED OPERATING CONDITIONS**

PARAMETER	SYMBOL	MIN	MAX	UNIT	NOTES
Case Operating Temperature	T <sub>C</sub>	-10	70	°C	CM13L-03F-3S-TC-L
		-40	85		CM13L-03F-3S-TI-L
Supply Voltage	V <sub>CC</sub>	3.1	3.5	V	
Supply Current	I <sub>TX</sub> + I <sub>RX</sub>	-	300	mA	

**TRANSMITTER ELECTRO-OPTICAL CHARACTERISTICS (V<sub>CC</sub> = 3.1V to 3.5V, T<sub>C</sub> = -10°C to 70°C, -40°C to 85°C)**

PARAMETER	SYMBOL	MIN	TYP.	MAX	UNIT
Data Rate	B	10	155	200	Mbps
Average Output Optical Power 62.5/125um fiber	P <sub>out</sub>	-20	-	-14	dBm
Average Output Optical Power 50/125um fiber	P <sub>out</sub>	-23.5	-	-14	dBm
Extinction Ratio	ER	10	-	-	dB
Center Wavelength	λ <sub>C</sub>	1270	1310	1380	nm
Spectral Width (FWHM)	Δλ		Fig 1		nm
Rise/Fall Time (10~90%)	T <sub>r,f</sub>	-	-	3	ns
Differential Input Voltage	V <sub>DIFF</sub>	0.4	-	2.0	V

**Figure 1 – LED spectral width limit**

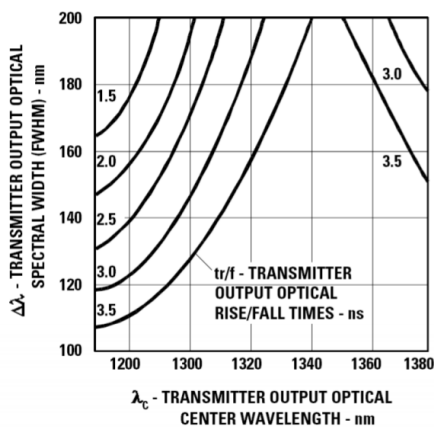

**RECEIVER ELECTRO-OPTICAL CHARACTERISTICS (V<sub>CC</sub> = 3.1V to 3.5V, T<sub>C</sub> = -10°C to 70°C, -40°C to 85°C)**

PARAMETER	SYMBOL	MIN	TYP.	MAX	UNIT	NOTES
Data Rate	B	10	155	200	Mbps	
Optical Input Power-Maximum	P <sub>IN</sub>	-8	-	-	dBm	Note 1
Receiver Input Power-Minimum (Sensitivity)	P <sub>IN</sub>	-	-	-31	dBm	Note 1
Operating Center Wavelength	λ <sub>C</sub>	1260	-	1600	nm	
Loss of Signal-Asserted	P <sub>A</sub>	-	-	-32	dBm	Average
Loss of Signal-Deasserted	P <sub>D</sub>	-47	-	-	dBm	Average
Loss of Signal-Hysteresis	P <sub>A</sub> -P <sub>D</sub>	0.5	-	-	dB	
Data Output Rise, Fall time (10~90%)	T <sub>r,f</sub>	-	1	2	ns	
Differential Output Voltage	V <sub>DIFF</sub>	0.5	-	1.8	V	
Receiver Loss of Signal Output Voltage-Low	RX_LOS <sub>L</sub>	0	-	0.5	V	
Receiver Loss of Signal Output Voltage-High	RX_LOS <sub>H</sub>	2.4	-	V <sub>CC</sub>	V	

**Note 1:** The input data is at 155.52 Mbps, 223–1 PRBS data pattern with 72 “1”s and 72 “0”s inserted per the ITU-T recommendation G.958 Appendix 1. The receiver is guaranteed to provide output data with Bit Error Rate (BER) better than or equal to 1 × 10<sup>-10</sup>.

**BLOCK DIAGRAM OF TRANSCEIVER**

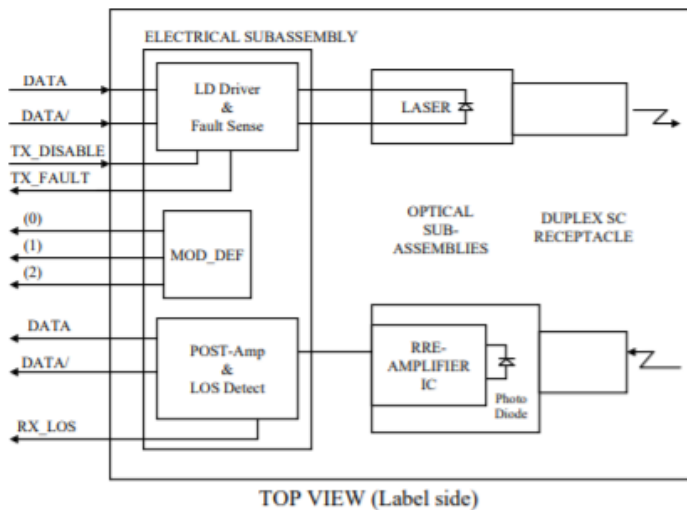

**Transmitter Section** - The transmitter section consists of a 1310 nm LED in an eye safe optical subassembly (OSA) which mates to the fiber cable. The laser OSA is driven by a LD driver IC which converts differential input LVPECL logic signals into an analog laser driving current.

**TX\_DISABLE** - The TX\_DISABLE signal is high (TTL logic “1”) to turn off the laser output. The laser will turn on when TX\_DISABLE is low (TTL logic “0”).

**Receiver Section** - The receiver utilizes an InGaAs PIN photodiode mounted together with a trans-impedance preamplifier IC in an OSA. This OSA is connected to a circuit providing post-amplification quantization, and optical signal detection.

**Receive Loss (RX\_LOS)** - The RX\_LOS is high (logic “1”) when there is no incoming light from the companion transceiver. This signal is normally used by the system for the diagnostic purpose. The signal is operated in TTL level.

**DIMENSIONS**

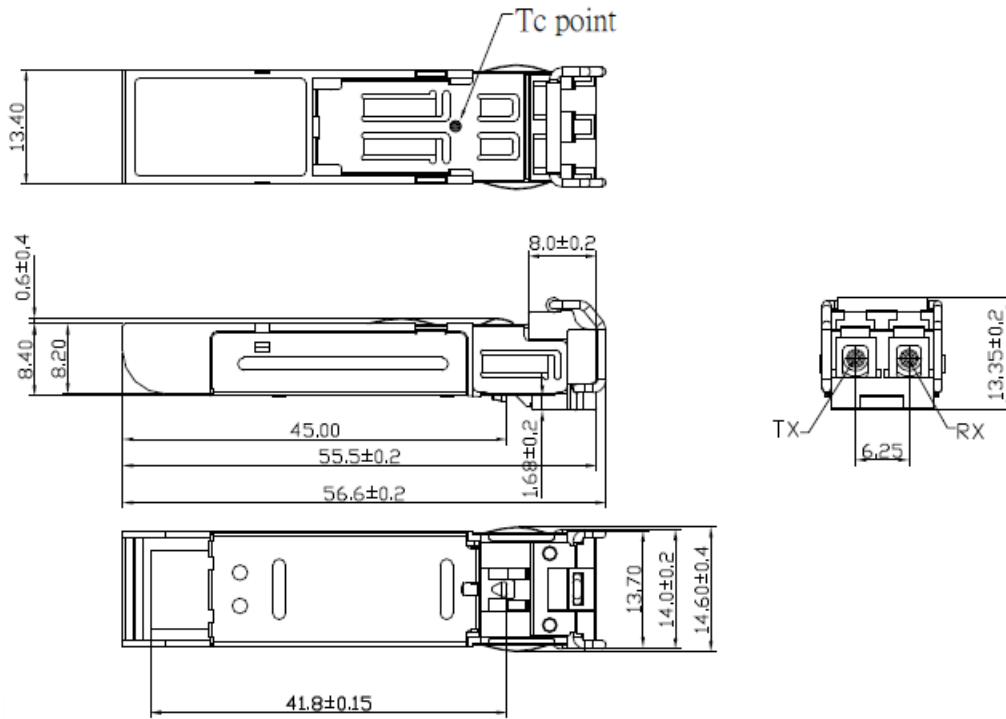

**DIMENSIONS ARE IN MILLIMETERS**

**ALL DIMENSIONS ARE  $\pm 0.1$ mm UNLESS OTHERWISE SPECIFIED**

Unit: mm

SFP HOST BOARD MECHANICAL LAYOUT

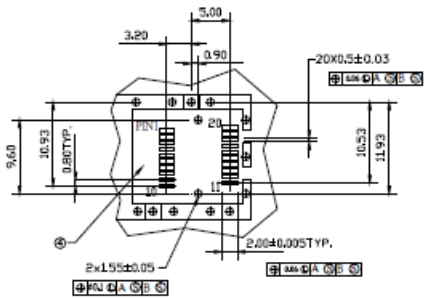
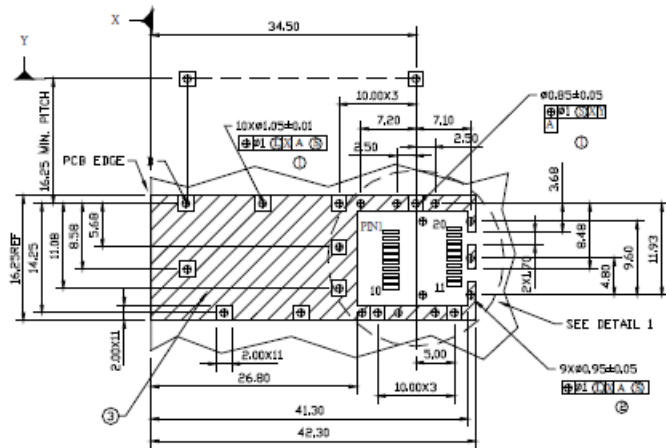

DETAIL 1

LEGEND

- 1.PADS AND VIAS ARE CHASSIS GROUND
- 2.THROUGH HOLES, PLATING OPTIONAL
- 3.HATCHED AREA DENOTES COMPONENT AND TRACE KEEPOUT(EXCEPT CHASSIS GROUND)
- 4.AREA DENOTES COMPONENT KEEPOUT (TRACES ALLOWED)

DIMENSIONS ARE IN MILLIMETERS

ASSEMBLY DRAWING

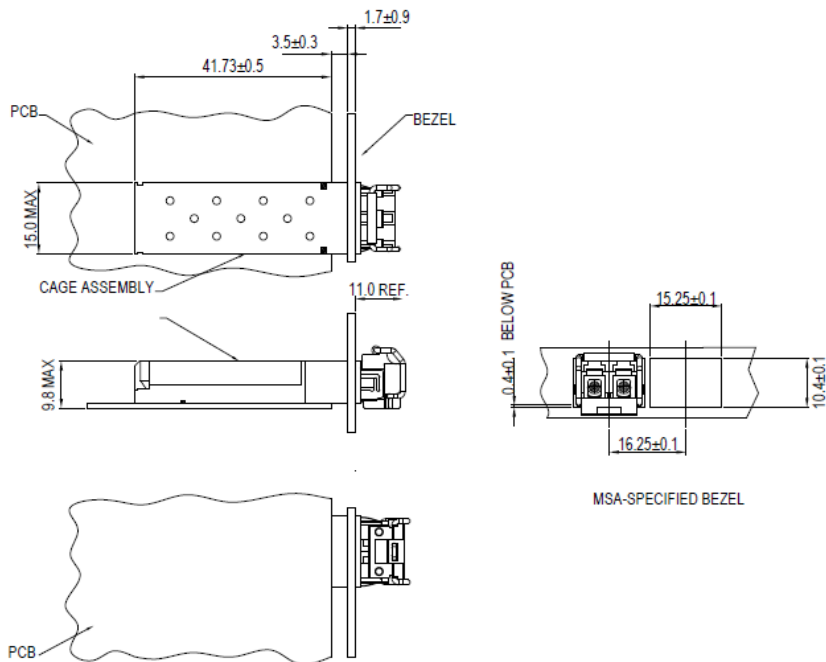

DIMENSIONS ARE IN MILLIMETERS

Unit: mm

**PIN ASSIGNMENT**

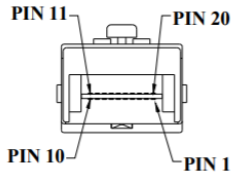

PIN	SIGNAL NAME	DESCRIPTION	PIN	SIGNAL NAME	DESCRIPTION
1	T <sub>GND</sub>	Transmit Ground	11	R <sub>GND</sub>	Receiver Ground
2	TX_FAULT	Transmit Fault	12	RX-	Receive Data Bar, Differential, ac coupled
3	TX_DISABLE	Transmit Disable	13	RX+	Receive Data, Differential, ac coupled
4	MOD_DEF (2)	SDA Serial Data Signal	14	R <sub>GND</sub>	Receiver Ground
5	MOD_DEF (1)	SCL Serial Clock Signal	15	V <sub>CCR</sub>	Receiver Power Supply
6	MOD_DEF (0)	TTL Low	16	V <sub>CCT</sub>	Transmitter Power Supply
7	RATE SELECT	Open Circuit	17	T <sub>GND</sub>	Transmitter Ground
8	RX_LOS	Receiver Loss of Signal, TTL High, open collector	18	TX+	Transmit Data, Differential, ac coupled
9	R <sub>GND</sub>	Receiver Ground	19	TX-	Transmit Data Bar, Differential, ac coupled
10	R <sub>GND</sub>	Receiver Ground	20	T <sub>GND</sub>	Transmitter Ground

**ADDITIONAL NOTES**

- Avoid eye or skin exposure to laser radiations.
- The device is sensitive to electro-static discharge (ESD). The device should be handled with ESD proof tools. To assemble the device on PCB, proper grounding is required to prevent ESD.
- Specifications are subject to change without notice.



**Lasermate Group, Inc.**  
 19608 Camino De Rosa  
 Walnut, CA 91789 USA  
 Tel: (909)718-0999  
 Fax: (909)718-0998  
[sales@lasermate.com](mailto:sales@lasermate.com)  
[www.lasermate.com](http://www.lasermate.com)