



PDT-A13P5-2GB3

2.5Gbps InGaAs PIN plus AGC Pre-Amplifier Photodiode in TO-46 Package, 5-pin

Overview

The Lasermate PDT-A13P5-2GB3 is a high-speed, high sensitivity 2.5Gb/s InGaAs photodetector integrated with a transimpedance amplifier (TIA) in a 5-pin TO-46 package with short cap lens, specifically designed for 1310nm/1550nm band optical fiber communications.

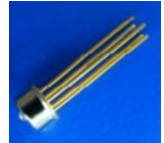

Features

- 1310nm/1550nm InGaAs PINTIA 5 pin TO
- Industry standard TO-46 package with short cap lens and tab-less
- Photocurrent monitoring available
- Single power supply +3.3V

Applications

- Optimized for fiber optic application
- Design for long wavelength 2.5Gbps applications

Specifications

Electro-Optical Characteristics (Typical values are at + 3.3V@25°C)						
Parameters	Symbol	Min.	Typ.	Max.	Unit	Conditions
Power Supply	V _{CC}	3.0	3.3	3.6	V	
Supply Current	I _{CC}		48	60	mA	No loads
Differential Responsivity	R _d	14		30	mV/uW	λ=1310nm, R _{load} =100ohm, P=-23dBm
Single Ended Responsivity	R _s	7		15	mV/uW	λ=1310nm, R _{load} =50ohm, P=-23dBm
Small-Signal Bandwidth	BW	1.4			GHz	
Low-Frequency Cut Off	LF		80		kHz	
Rise/Fall Time (20-80%)	tr/tf		170	200	ps	P=-23dBm, λ=1310nm
Saturation Power	P _{sat}	0			dBm	
Single Ended Output Impedance	R _o		50		ohm	
Wavelength	λ	1260		1620	nm	
Sensitivity				-25	dBm	λ=1310nm, @2488.32Mbps, PRBS23, ER=10dB, BER=10 ⁻¹⁰

Absolute Maximum Ratings					
Parameters	Min.	Max.	Unit	Conditions	
Storage Temperature	-40	100	°C		
Operating Temperature	-40	85	°C		
Lead Solder Temperature		260	°C	10 seconds	

Typical Characteristics

Eye Diagram

R_{load} = 50ohm, P = -23dBm @2488.32Mbps, 1310nm, PRBS 23.

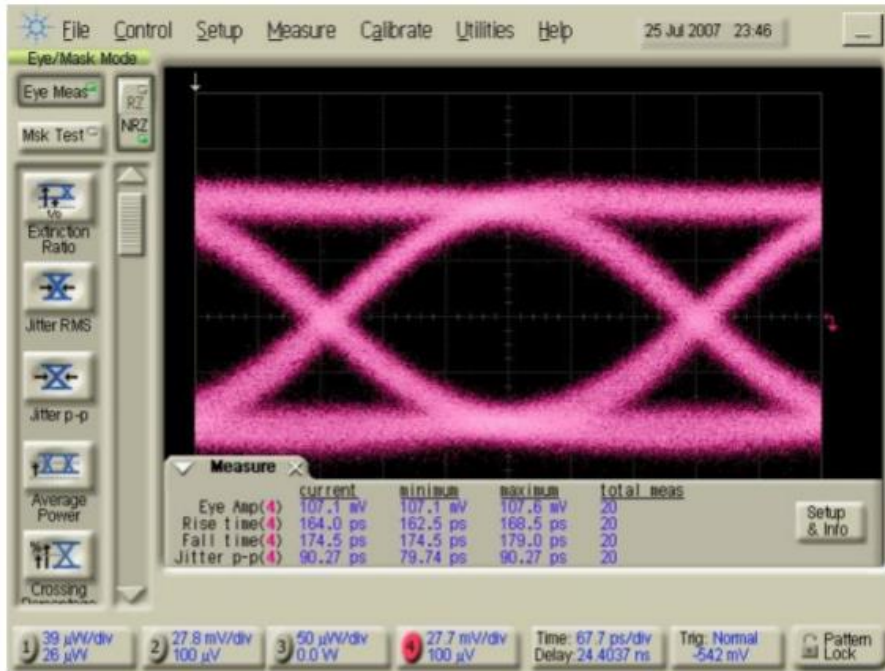

tr=164.0ps, tf=174.5ps, Jitter p-p=90.27ps

Outline Dimensions (unit: mm)

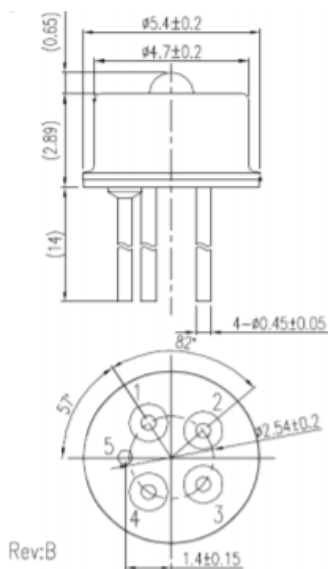

Pinout:

1. Dout
2. Vcc
3. Isink
4. Dout
5. Gnd

Note: Specifications are subject to change without notice.