



## PDT-A13P4-1GB3

### 1.25Gbps InGaAs PIN plus AGC Pre-Amplifier Photodiode in TO-46 Package, 4-pin

#### Overview

The Lasermate PDT-A13P4-1GB3 is a high-speed, high sensitivity 1.25Gb/s InGaAs photodetector integrated with a transimpedance amplifier (TIA) in a 4-pin TO-46 package with short cap lens, specifically designed for 1310nm/1550nm band optical fiber communications.

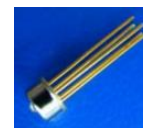

#### Features

- 1310nm/1550nm InGaAs PINTIA 4 pin TO
- Industry standard TO-46 package with short cap lens and tab-less
- Single power supply +3.3V

#### Applications

- Optimized for fiber optic application
- Design for long wavelength 1.25Gbps applications

#### Specifications

Electro-Optical Characteristics (Typical values are at + 3.3V@25°C)						
Parameters	Symbol	Min.	Typ.	Max.	Unit	Conditions
Power Supply	V <sub>cc</sub>	3.0	3.3	3.6	V	
Supply Current	I <sub>cc</sub>		22	30	mA	No loads
Differential Responsivity	R <sub>d</sub>	14		30	mV/uW	λ=1310nm, R <sub>load</sub> =100ohm, P=-26dBm
Single Ended Responsivity	R <sub>s</sub>	7		15	mV/uW	λ=1310nm, R <sub>load</sub> =50ohm, P=-26dBm
Small-Signal Bandwidth	BW	700			MHz	
Low-Frequency Cut Off	LF			100	kHz	
Rise/Fall Time (20-80%)	tr/tf			400	ps	P=-26dBm, T <sub>A</sub> =25°C
Saturation Power	P <sub>sat</sub>	0			dBm	
Single Ended Output Impedance	R <sub>o</sub>		50		ohm	
Wavelength	λ	1260		1620	nm	
Sensitivity				-28	dBm	λ=1310nm, @1244.16Mbps, PRBS7, ER=10dB, BER=10 <sup>-10</sup>

Absolute Maximum Ratings					
Parameters	Min.	Max.	Unit	Conditions	
Storage Temperature	-40	100	°C		
Operating Temperature	-40	85	°C		
Lead Solder Temperature		260	°C	10 seconds	

## Typical Characteristics

### Eye Diagram

R<sub>load</sub> = 50ohm, P = -26dBm@1244.16Mbps, 1310nm, PRBS 7

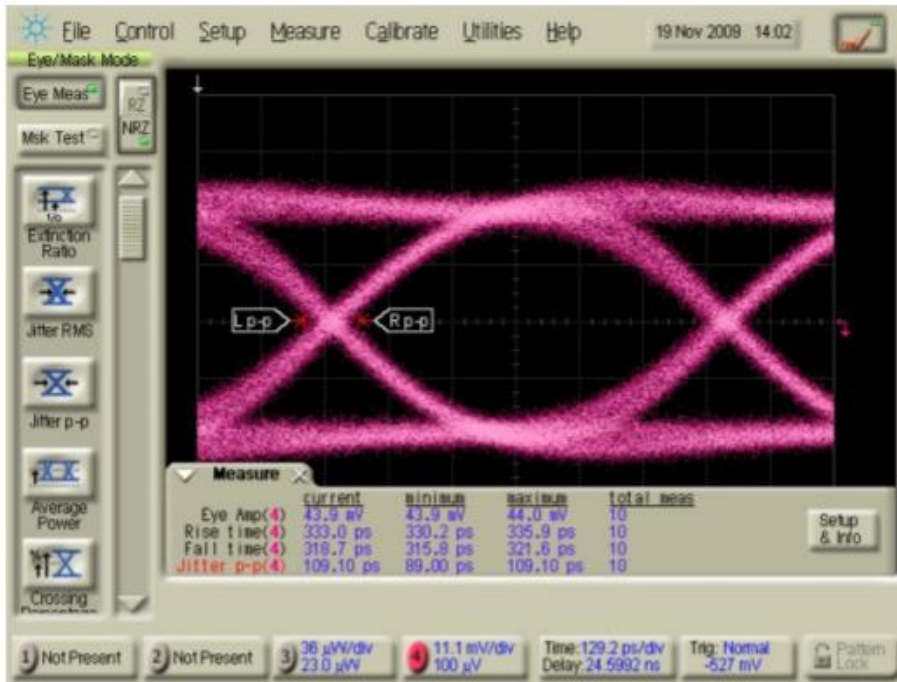

tr=333.0ps, tf=318.7ps, Jitter p-p=109.1ps

### Outline Dimensions (unit: mm)

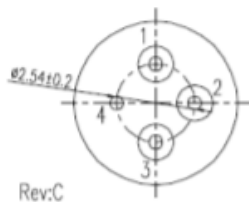
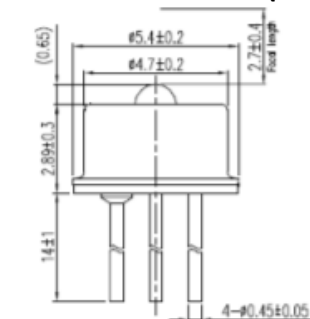

#### Pinout:

1. Vcc
2. Dout
3. Dout
4. Gnd

Note: Specifications are subject to change without notice.