



PDA-A13x3-2G

2.5GHz 1310nm/1550nm Analog InGaAs PIN Photodiode in TO-46 Package, 3-pin

Overview

The Lasermate PDA-A13A3-2G is an Analog InGaAs photodiode designed for analog optical links with bandwidth up to 2.5GHz.



Features

- InGaAs PIN PD 3 pin TO for Analog application
- Industry standard TO-46 package with cap lens and tab-less
- High responsivity at 1310nm and 1550nm
- Low inter-modulation distortion

Applications

- Optimized for fiber optic application
- Suitable for CATV application

Specifications

Electro-Optical Characteristics						
Parameters	Symbol	Min.	Typ.	Max.	Unit	Conditions
Responsivity	R	0.8	0.9		A/W	$\lambda=1310\text{nm}$, $V_R=5\text{V}$
		0.9	1			$\lambda=1550\text{nm}$, $V_R=5\text{V}$
Dark Current	I_D		0.1	1	nA	$V_R=5\text{V}$, $T_A=25^\circ\text{C}$
Breakdown Voltage	V_{BD}	25	50		V	$I_R=10\mu\text{A}$
Second Order Inter-Modulation Distortion	IMD2		-75	-70	dBc	$\lambda=1310\text{nm}$ ⁽¹⁾
			-75	-70		$\lambda=1550\text{nm}$ ⁽¹⁾
Third Order Inter-Modulation Distortion	IMD3		-85	-80	dBc	$\lambda=1310\text{nm}$ ⁽¹⁾
			-85	-80		$\lambda=1550\text{nm}$ ⁽¹⁾
Capacitance	C		0.56	0.7	pF	$V_R=5\text{V}$, $f=1\text{MHz}$
Bandwidth	BW	2.5	3.2			$V_R=5\text{V}$

(1) IMD2 measured at $V_R = 12\text{V}$, $P_{\text{avg}} = 0\text{dBm}$, $\text{OMI} = 0.7$, $R_{\text{load}} = 50\Omega$, $f_1+f_2 = 850\text{MHz}$, $f_1-f_2 = 50\text{MHz}$. All are measured at 25°C .

Absolute Maximum Ratings					
Parameters	Min.	Max.	Unit	Conditions	
Storage Temperature	-40	125	$^\circ\text{C}$		
Operating Temperature	-40	85	$^\circ\text{C}$		
Lead Solder Temperature		260	$^\circ\text{C}$	10 seconds	
Forward Current		10	mA		
Reverse Voltage		20	V		

Typical Characteristics

Fig. 1 Typical Dark Current and Forward Current

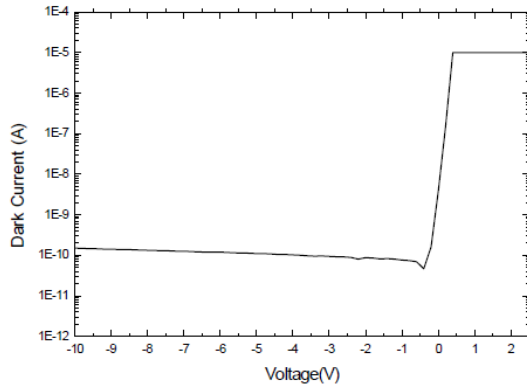

Fig. 2 Typical Photo-Current

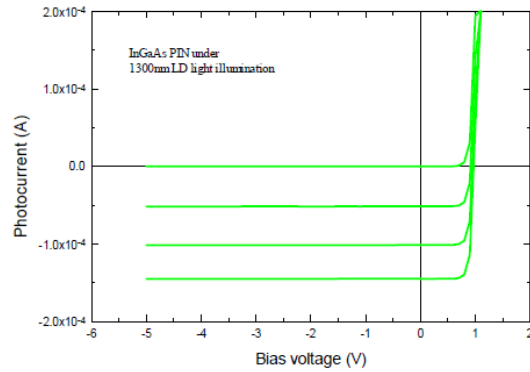

Fig. 3 Typical Breakdown Curve

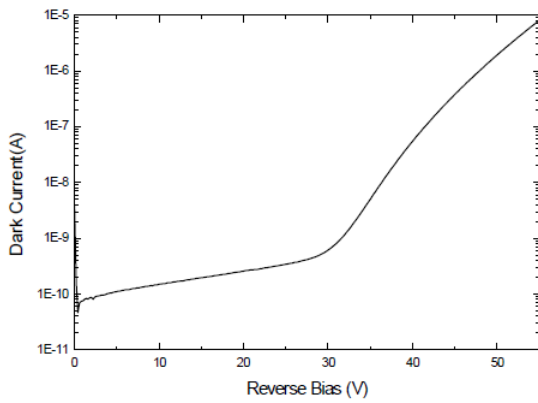
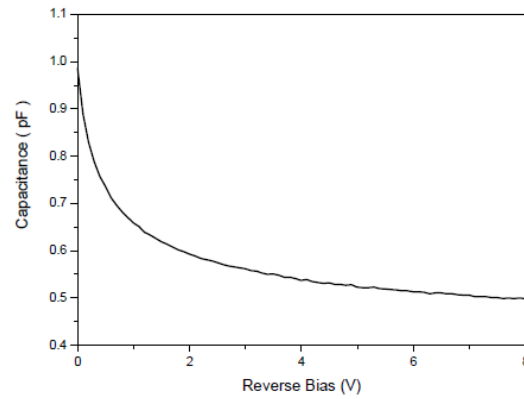
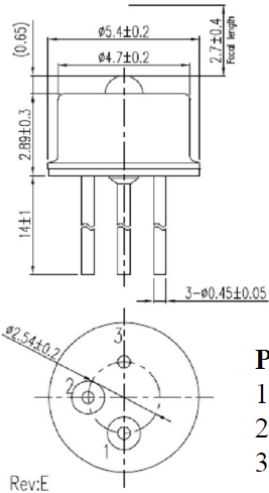

Fig. 4 Typical C-V Curve



Outline Dimensions (unit: mm)

PDA-A13A3-2G



PDA-A13B3-2G

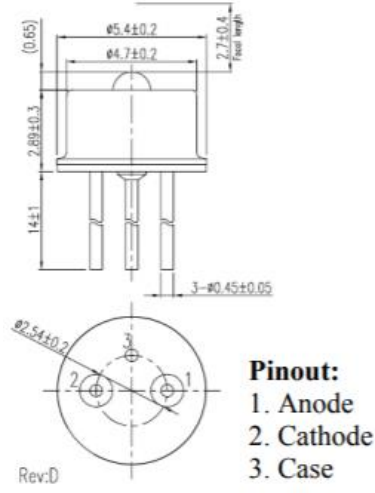

Note: Specifications are subject to change without notice.