

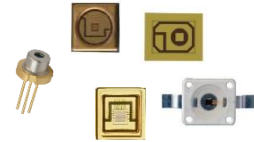

## 850nm 1000mW CW VCSEL Diode

### VCx-850C1WA



### Description

The Lasermate VCx-850C1WA is an 850nm wavelength, 1000mW output power, CW operating mode, Vertical Cavity Surface Emitting Laser (VCSEL) diode. Available in different package types, the VCSEL features single longitudinal mode, low wavelength drift, low threshold current, and easy collimation. Ideal for 3D sensor, proximity sensor, IR illumination, medical application, range finder sensor.

### Features

- 850nm VCSEL Diode
- Output power: 1000mW
- Single longitudinal mode
- Low wavelength drift
- Oxide isolation technology
- Low threshold current
- Small emission area
- Easy to collimate

### Applications

- 3D sensors
- Proximity sensor
- IR illumination
- Medical application
- Range finder sensor

### Product Overview

The following table lists the available part numbers, as well as the package type of each of the part numbers.

Part Number	Package
VC35A-850C1WA	3535 Package, Substrate AlN
VC70C-850C1WA	7060 Package, Substrate CuAg

**Specifications**

Absolute Maximum Ratings				
Parameters	Symbol	Rating	Unit	Conditions
Case Operating Temperature	Top	-40 to 85	°C	
Storage Temperature	Tstg	-40 to 105	°C	
Reflow Soldering Temperature	Tsol	260	°C	5 seconds
Reverse Voltage	Vr	5	V	
Maximum Continuous Current	I <sub>max</sub>	3	A	
ESD Exposure (Human Body) Model	ESD	2k-4k (Class 2)	V	
ESD Exposure (Machine) Model	ESD	200-400 (Class B)	V	

Notes:

- Stresses greater than those listed under “Absolute Maximum Ratings” may cause permanent damage to the device. This is a stress rating only and functional operation of the device at these or other conditions above those indicated in the operations section for expanded periods of time may affect reliability.
- In its maximum rating diode laser operation could damage its performance or cause potential safety hazard such as equipment failure.
- Electrostatic discharge is the main reason for laser fault of the diode. Take effective precautions against ESD. When dealing with laser diodes, use wrist strap, grounding work surface and strict antistatic technology.

Electro-Optical Characteristics (T <sub>op</sub> =25°C, CW mode)						
Parameters	Symbol	Min.	Typ.	Max.	Unit	Conditions
Optical Output Power	P <sub>o</sub>	-	1000	-	mW	I <sub>F</sub> =1.2A
Threshold Current	I <sub>th</sub>	-	0.15	-	A	
Forward Current	I <sub>F</sub>	-	1.2	-	A	
Slope Efficiency	η	-	1.0	-	W/A	P <sub>o</sub> =1000mW
Power Conversion Efficiency	PCE	-	36	-	%	I <sub>F</sub> =1.2A
Peak Wavelength	λ <sub>P</sub>	840	850	860	nm	I <sub>F</sub> =1.2A
Laser Forward Voltage	V <sub>F</sub>	-	2.18	-	V	I <sub>F</sub> =1.2A
Series Resistance	R <sub>S</sub>	-	0.5	-	Ω	I <sub>F</sub> =1.2A
Beam Divergence	FWHM <sub>B</sub>	-	20	-	deg	
Wavelength Temperature Drift	Δλ <sub>P</sub> / ΔT	-	-	0.07	nm/°C	I <sub>F</sub> =1.2A
Emission Area			470x470		mm <sup>2</sup>	
No. of Emission Aperture			113			

Note: Electro-optical characteristic with a package or diffuser would require further evaluation. Values are based on limited sample size and estimated values.

**Typical Characteristics**

LIV Graph

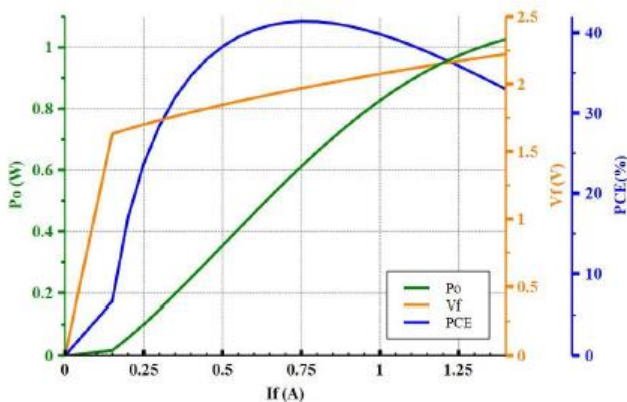

Intensity vs. Wavelength

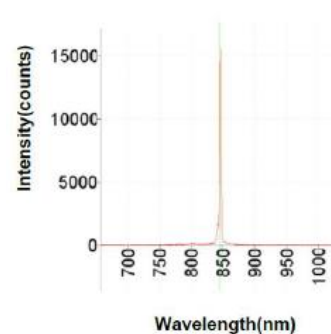

**Outline Dimensions (unit: mm)**

VC35A-850C1WA (3535 SMD Package, Substrate AlN)

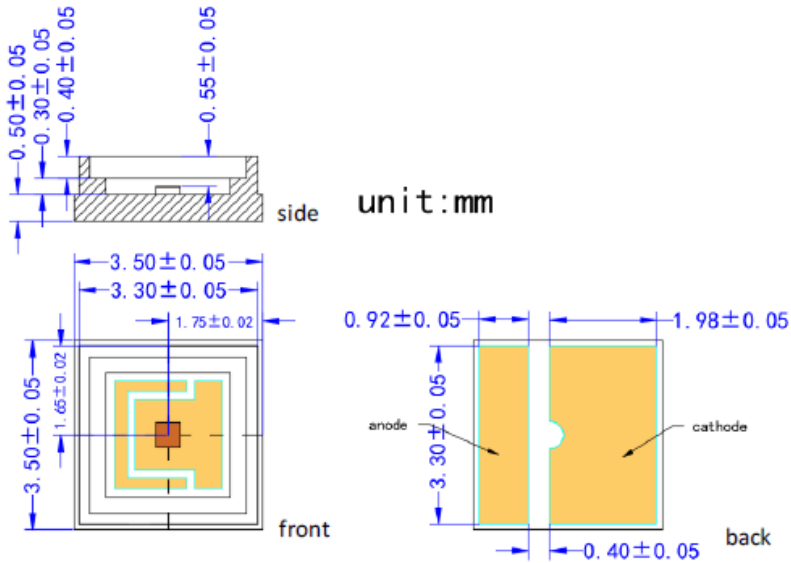

VC70C-850C1WA (7060 SMD Package, Substrate CuAg)

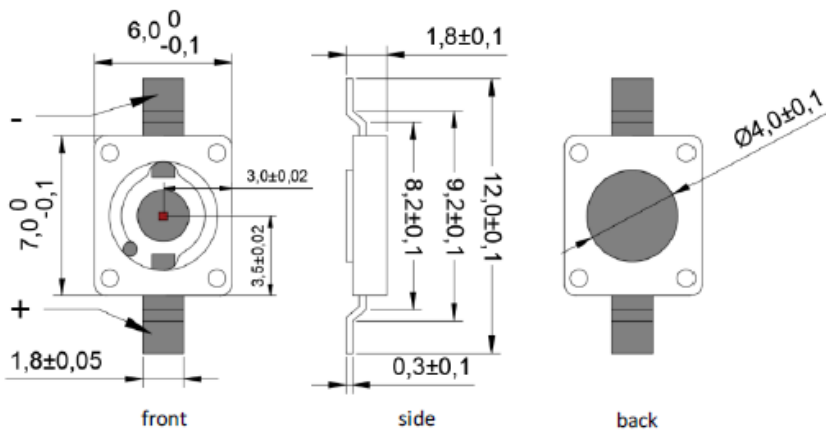

## SMT Reflow Soldering Curve

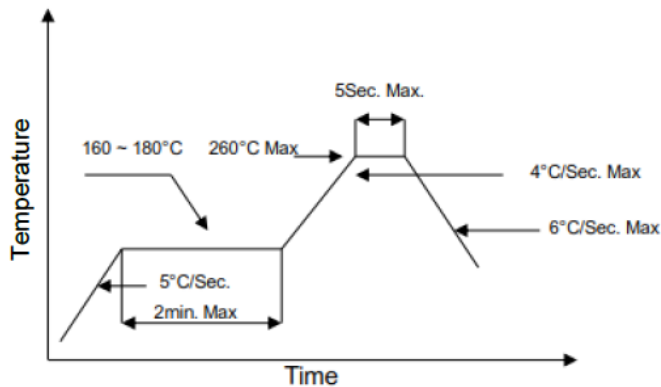

Note: Reflow soldering can be operated only one time. During the temperature ramp-up, no forces may be exerted on the LD which would deform or damage them. After soldering is completed, please do not process until the product temperature ramps down to room temperature.

## Additional Notes

1. Please use solder paste to cure the laser diode.
2. Please make sure that the heat of VCSEL diode has been completely conducted to metal shell to avoid affecting the optical power output.
3. This VCSEL diode can be only used in constant voltage and current.
4. Please do not aim the laser at people or animals.
5. You may observe the laser spot through an image monitoring equipment.
6. Please do not touch VCSEL diode surface by naked hands or squeeze the sealant on VCSEL diode surface. It may cause wrong optical angle and distorted laser spot, and even damage the VCSEL diode.
7. Please use ceramic suction nozzle to absorb the VCSEL diode, so as to avoid VCSEL diode sticking to the nozzle.
8. Please add a 0.02s blowing action after locating the laser diode to aluminum substrate.
9. Specifications are subject to change without notice.



**Lasermate Group, Inc.**  
 19608 Camino De Rosa  
 Walnut, CA 91789 USA  
 Tel: (909)718-0999  
 Fax: (909)718-0998  
[sales@lasermate.com](mailto:sales@lasermate.com)  
[www.lasermate.com](http://www.lasermate.com)