



VCT-A98A31-3

1.25/2.5Gbps 980nm VCSEL TO-46, Ball Lens

Description

The Lasermate VCT-A98A31-3 is a 980nm wavelength, Vertical Cavity Surface Emitting Laser (VCSEL) diode in TO-46 package with ball lens designed for use in 1.25/2.5Gbps datacom applications.



Features

- 980nm wavelength range
- High data rate 1.25/2.5Gbps
- High reliability
- Low current and voltage
- Ball lens type TO-46 can package

Applications

- High speed Data communications
- Fiber channel

Specifications

Absolute Maximum Ratings				
Parameters	Min.	Max.	Unit	Conditions
Storage Temperature	-40	100	°C	
Operating Temperature	0	85	°C	
Lead Solder Temperature		260	°C	10 seconds
Continuous Forward Current		12	mA	
Continuous Reverse Voltage		5	V	10uA

Electro-Optical Characteristics (T _a =25°C unless otherwise stated)						
Parameters	Symbol	Min.	Typ.	Max.	Unit	Conditions
Threshold Current	I _{th}		1.5		mA	CW
Slope Efficiency	η	0.2	0.3	0.5	W/A	I _f =6mA
Optical Output Power	P _o		1.5		mW	I _f =6mA
Peak Wavelength	λ _p	970	980	990	nm	I _f =6mA
Spectral Bandwidth (RMS)	Δλ			0.85	nm	I _f =6mA
Beam Divergence	Θ	14		30	°	P _o =1.5mW, (Full width, 1/e ²)
Operating Voltage	V _f		1.6	2.0	V	I _f =6mA
Breakdown Voltage	V _b		-10		V	
Dynamic Resistance	R _d	20	35	55	Ohm	I _f =6mA

Thermal Characteristics						
Parameters	Symbol	Min.	Typ.	Max.	Unit	Conditions
I _{th} Temperature Variation	ΔI _{th}		1.5		mA	T _a =0 to 85°C
η Temperature Coefficient	Δη/ΔT		-0.5		%/°C	T _a =0 to 85°C, I _f =6mA
λ Temperature Coefficient	Δλ/ΔT		0.06		nm/°C	T _a =0 to 85°C, I _f =6mA

Outline Dimensions (unit: mm)

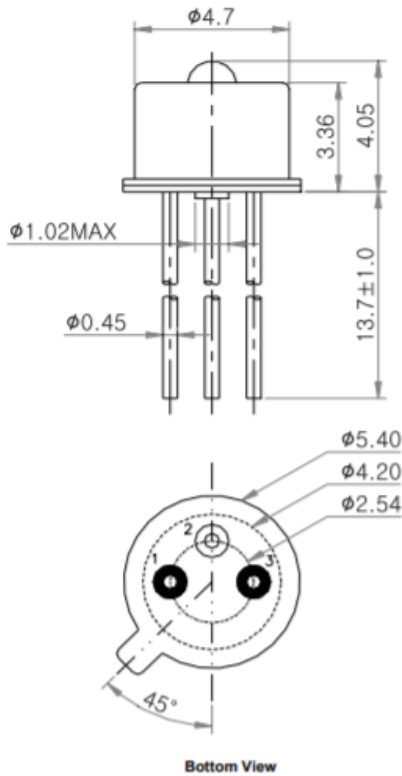

Pin Configuration

Pin Number	Function
1	VCSEL Anode
2	NC
3	VCSEL Cathode

Additional Notes

- The inherent design of this component causes it to be sensitive to electrostatic discharge (ESD). To prevent ESD-induced damage and/or degradation to equipment, take normal ESD precautions when handling this product.
- Specifications are subject to change without notice.