



T15F-PYZ-WM-D 1550nm Coaxial FP Pigtail Laser Diode

Overview

The Lasermate T15F-PYZ-WM-D is a 1550nm wavelength, Fabry-Perot laser diode in pigtailed package with output power up to >2mW, and capable of reaching 2.5Gbps data rate operation. The laser is designed for use in telecommunication applications.



Features

- 1550nm MQW-FP laser diode (LD)
- Data Rate: 155Mbps up to 2.5Gbps
- Uncooled operation at -40 to 85°C
- Hermetically sealed active component
- Built-in InGaAs monitor PIN photodiode (PD)

Packaging

- Fiber pigtailed with optional FC/ST/SC/LC connector

Applications

- ATM/SONET OC-3/OC-12/OC-24
- SDH STM-1/STM-4/STM-8
- Stable emitting source at specific wavelength

Ordering Information

Read Model No.	T15F-PYZ-WM-D
T15F = Laser	1550nm FP laser
P = Package	Pigtailed with 9/125um SM fiber
Y = Connector	None (NO) ; FC/PC (FC) ; SC/PC (SC) ; ST/PC (ST) ; LC/PC (LC) ; FC/APC (FA) ; SC/APC (CA) ; ST/APC (TA)
Z = Output power	>0.2mW (S) ; >0.5mW (M) ; >1mW (H) ; >2mW (2)
W = Pin configuration	A pinout (A) ; B pinout (B) ; C pinout (C)
M = Mount	No flange (0) ; Horizontal mount (1)
D = Data rate	1.25Gbps (1G) ; 2.5Gbps (2G)



Specifications

Absolute Maximum Ratings				
Parameters	Symbol	Value	Unit	Conditions
Storage temperature	Tstg	-40 to +85	°C	
Operating case temperature	Top	-40 to +85	°C	
Peak optical output power	Po	3	mW	
Forward current (LD)	I _{FLD}	100	mA	
Reverse voltage (LD)	V _{RLD}	2	V	
Reverse current (PD)	I _{RPD}	5	mA	
Reverse voltage (PD)	V _{RPD}	15	V	
Soldering temperature	Stemp	260	°C	10 seconds

Electro-Optical Characteristics (CW @ T _c = 25°C unless otherwise noted)						
Parameters	Symbol	Min.	Typ.	Max.	Unit	Conditions
Central wavelength	λ_c	1520	1550	1570	nm	CW, Pf
Spectral width	$\Delta\lambda$	-	2	3	nm	Pf
Threshold current	I _{th}	-	10	15	mA	CW
Fiber output power	Pf	0.2			mW	CW, I _f =I _{th} +20mA
		0.5				
		1.0				
		2.0				
Operating voltage	V _{op}	-	1.1	1.5	V	Pf
Rise time / Fall time	t _r /t _f	-	0.15	0.3	nsec	I _b = I _{th} , 20%~80%
Monitor current	I _m	100	-	1000	uA	Pf, V _{rp} =5V
Monitor dark current	I _d	-	0.1	100	nA	V _{rp} =5V
Monitor capacitance	C	-	10	20	pF	V _{rp} =5V, f=1MHz
Tracking error*	Δ Pf/ Pf	-	±1.0	±1.5	dB	APC, T _c =-40~+85°C

*I_m=constant @ Pf, T_c=25 °C

Fiber Pigtail Specifications						
Parameters	Symbol	Min.	Typ.	Max.	Unit	
Fiber type	Single Mode Fiber (Flame Retardant Hytrel Coating)					
Cladding diameter	D _{cl}	122	125	128	um	
Mode field diameter	D _{mf}	-	10	-	um	
Coating diameter	D _{bc}	-	0.9	1	mm	
Pigtail length*	L	0.9	1.0	1.1	m	
Bending radius	R _b	30	-	-	mm	
Connector	TBD					

*From the ferrule-end to the bottom of TO-header.

Outline Dimensions (unit: mm)

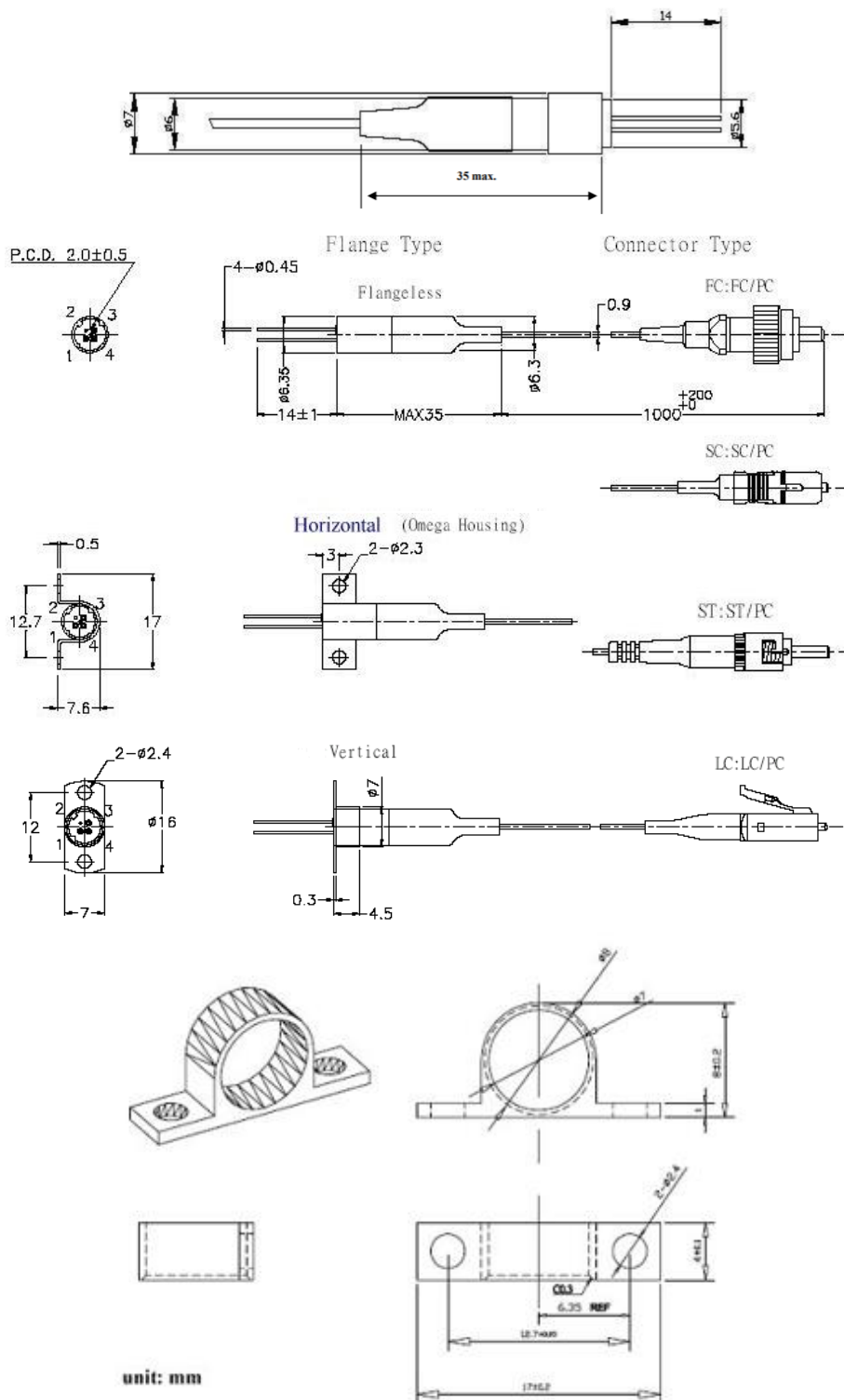

Pin Assignment

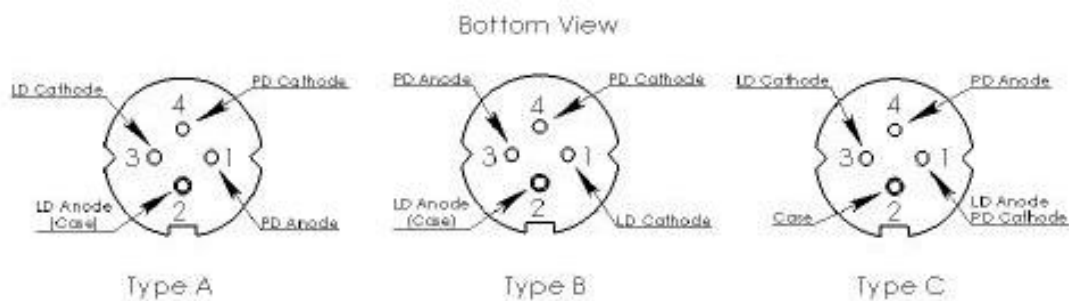

Pin Number	Type A	Type B	Type C
1	PD Anode	LD Cathode	LD Anode, PD Cathode
2	LD Anode (case)	LD Anode (case)	Case
3	LD Cathode	PD Anode	LD Cathode
4	PD Cathode	PD Cathode	PD Cathode

Additional Notes

- Avoid eye or skin exposure to laser radiations.
- The device is sensitive to electro-static discharge (ESD). The device should be handled with ESD proof tools. To assemble the device on PCB, proper grounding is required to prevent ESD.
- Specifications are subject to change without notice.