



LDV808QxWC

808nm QCW Conduction-Cooled Vertical Diode Laser Stack

Description

The LDV808QxWC is an 808nm wavelength, vertical stacked diode laser array providing 100W/bar, 200W/bar or 300W/bar QCW and generating output powers up to 6000W. The QCW diode laser array is conduction-cooled and requires no water cooling. The diode laser array is designed to provide the highest reliability and efficiency in pumping, industrial and medical applications.



Features

- 808nm Conduction-Cooled Vertical Stacked Array
- Containing up to 20 bars (Up to 300W CW/bar)
- High output power: Up to 6000W
- Spectral width: <5 nm
- High reliability, High efficiency

Applications

- Pumping
- Industrial
- Medical

Product Overview

The following table lists the available part numbers, as well as the total output power, output power per bar, number of bars, and cooling method of each of the part numbers.

Part Number	Total Output Power	Output Power per Bar	Number of Bars	Cooling Method
LDV808Q500WC	500W	100W	5	Conduction-Cooled
LDV808Q1000WC	1000W	100W	10	Conduction-Cooled
LDV808Q2000WC	2000W	100W	20	Conduction-Cooled
LDV808Q4000WC	4000W	200W	20	Conduction-Cooled
LDV808Q1500WC	1500W	300W	5	Conduction-Cooled
LDV808Q3000WC	3000W	300W	10	Conduction-Cooled
LDV808Q6000WC	6000W	300W	20	Conduction-Cooled



Specifications (T_C = 25°C)

Optical Characteristics									
Parameter	Symbol	Value							Unit
Center wavelength	λ_c	808							nm
Operation mode		QCW							-
Maximum output power	P_o	500	1000	2000	4000	1500	3000	6000	W
Output power/bar	P_o/bar	100	100	100	200	300	300	300	W
Bar quantity		5	10	20	20	5	10	20	-
Spectral width	$\Delta\lambda$	<5							nm
Wavelength Temperature coefficient		0.28							nm/°C
Pulse width		<500							μs
Duty ratio		≤4							%
Fast axis divergence	θ_{\perp}	<39							deg
Slow axis divergence	θ_{\parallel}	<10							deg
Electrical Characteristics									
Parameter	Symbol	Value							Unit
Threshold current	I_{th}	<25	<25	<25	<30	<30	<30	<30	A
Operating current	I_{op}	<110	<110	<110	<200	<300	<300	<300	A
Operating voltage/bar	V_{op}	<2.0	<2.0	<2.0	<2.0	<2.0	<2.0	<2.0	V
Thermal Characteristics									
Parameter	Symbol	Value							Unit
Operating temperature	T_{op}	15 to 35							°C
Storage temperature	T_{stg}	-10 to +60							°C

Mechanical Outline (unit: mm)

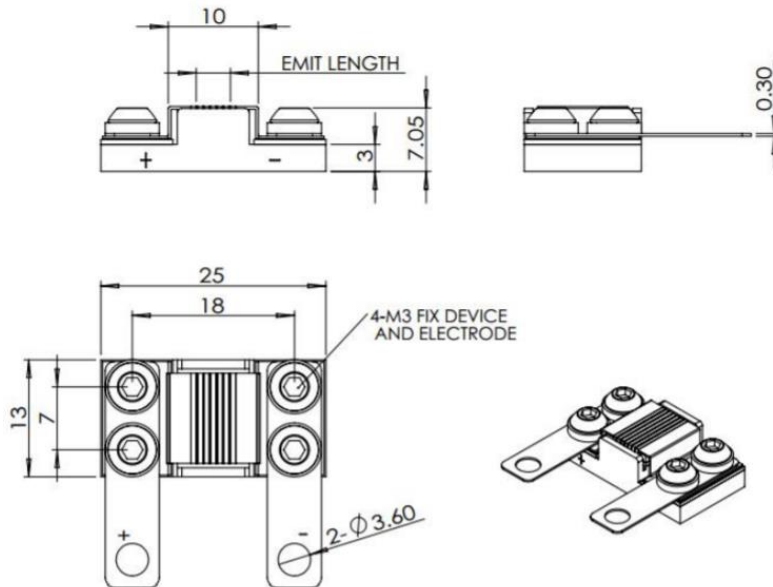

Notes

- Specifications are subject to change without notice. Ensure that you have the latest specification by contacting us prior to purchase or use of the product.
- Please make sure that the laser diode is operated under the temperature between 15 °C and 35 °C, as high temperature will increase threshold current, decrease exchange rate and accelerate the aging.
- Please take measures to avoid condensation, which will cause aging of laser diode.
- Take precautions to avoid electrostatic discharge and/or momentary power spikes. A change in the characteristics of the laser or premature failure may result.
- Observing visible or invisible laser beams with human eye directly, or indirectly, can cause permanent damage. Do not look directly into the laser output port.