



LDBxxxCxWC

CW Conduction-Cooled Single Laser Diode Bar (808nm, 915nm, 940nm, 980nm, 1064nm)

Description

The LDBxxxCxWC 808nm, 915nm, 940nm, 980nm and 1064nm conduction-cooled, high power laser diode bar offers up to 60 Watts CW. With its scalable power, the diode laser packaged bar can be used in a pumping, industrial and medical applications that require high-peak power. The compact package can be configured for enhanced brightness through stacking, scaled linearly or vertically for optimized light and material integration.



Features

- 808nm/915nm/940nm/980nm/1064nm Conduction-Cooled Packaged Diode Laser Bar
- High output power: Up to 60W CW
- High brightness
- Modular and compact design for ease of integration
- Packaged 10mm laser diode bar

Applications

- Pumping
- Industrial
- Medical
- Printing
- Scientific research



Specifications (T_c = 25°C)

Part Number	LDB808C20WC	LDB808C40WC	LDB808C60WC
Optical Characteristics			
Center wavelength (λ_c)	808 nm	808 nm	808 nm
Operation mode	CW	CW	CW
Output power (P _o)	20 W	40 W	60 W
Spectral width ($\Delta\lambda$)	<5 nm	<5 nm	<5 nm
Wavelength Temperature coefficient	0.28 nm/°C	0.28 nm/°C	0.28 nm/°C
Fast axis divergence (θ_{\perp})	<39 deg	<39 deg	<39 deg
Slow axis divergence (θ_{\parallel})	<10 deg	<10 deg	<10 deg
Electrical Characteristics			
Threshold current (I _{th})	<5 A	<7 A	<15 A
Operating current (I _{op})	<20 A	<40 A	<70 A
Operating voltage (V _{op})	<2.0 V	<2.0 V	<2.0 V
Thermal Characteristics			
Operating temperature (T _{op})	15 to 35 °C	15 to 35 °C	15 to 35 °C
Storage temperature (T _{stg})	-10 to +60 °C	-10 to +60 °C	-10 to +60 °C

Part Number	LDB915C60WC	LDB940C60WC	LDB980C60WC
Optical Characteristics			
Center wavelength (λ_c)	915 nm	940 nm	980 nm
Operation mode	CW	CW	CW
Output power (P _o)	60 W	60 W	60 W
Spectral width ($\Delta\lambda$)	<5 nm	<5 nm	<5 nm
Wavelength Temperature coefficient	0.28 nm/°C	0.28 nm/°C	0.28 nm/°C
Fast axis divergence (θ_{\perp})	<39 deg	<39 deg	<39 deg
Slow axis divergence (θ_{\parallel})	<10 deg	<10 deg	<10 deg
Electrical Characteristics			
Threshold current (I _{th})	<15 A	<15 A	<15 A
Operating current (I _{op})	<70 A	<70 A	<70 A
Operating voltage (V _{op})	<2.0 V	<2.0 V	<2.0 V
Thermal Characteristics			
Operating temperature (T _{op})	15 to 35 °C	15 to 35 °C	15 to 35 °C
Storage temperature (T _{stg})	-10 to +60 °C	-10 to +60 °C	-10 to +60 °C



Part Number	LDB1064C40WC
Optical Characteristics	
Center wavelength (λ_c)	1064 nm
Operation mode	CW
Output power (P_o)	40 W
Spectral width ($\Delta\lambda$)	<5 nm
Wavelength Temperature coefficient	0.28 nm/°C
Fast axis divergence (θ_{\perp})	<39 deg
Slow axis divergence (θ_{\parallel})	<10 deg
Electrical Characteristics	
Threshold current (I_{th})	<7 A
Operating current (I_{op})	<50 A
Operating voltage (V_{op})	<2.0 V
Thermal Characteristics	
Operating temperature (T_{op})	15 to 35 °C
Storage temperature (T_{stg})	-10 to +60 °C

Mechanical Outline (unit: mm)

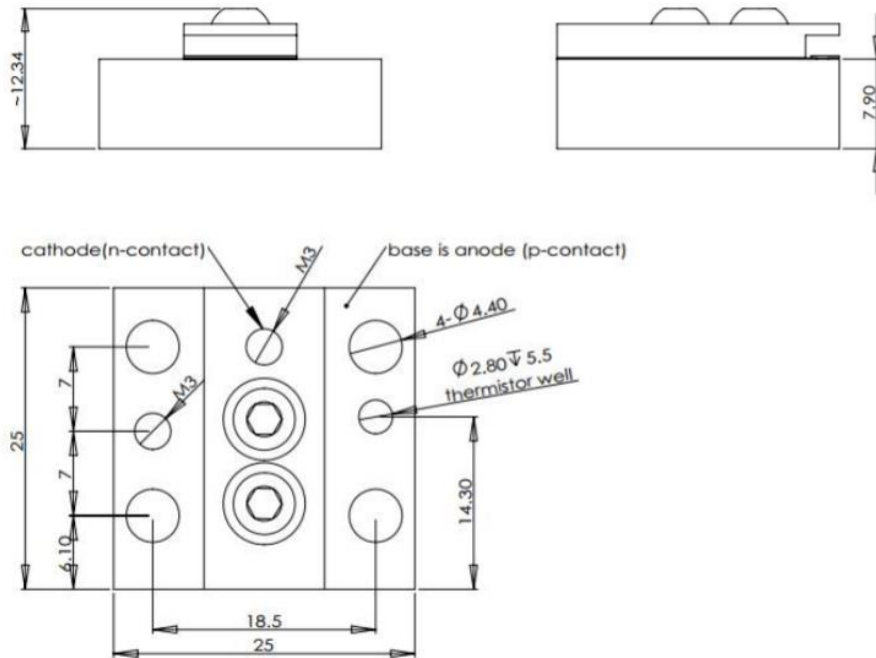

Notes

1. Specifications are subject to change without notice. Ensure that you have the latest specification by contacting us prior to purchase or use of the product.
2. Please make sure that the laser diode is operated under the temperature between 15 °C and 35 °C, as high temperature will increase threshold current, decrease exchange rate and accelerate the aging.
3. Please take measures to avoid condensation, which will cause aging of laser diode.
4. Take precautions to avoid electrostatic discharge and/or momentary power spikes. A change in the characteristics of the laser or premature failure may result.
5. Observing visible or invisible laser beams with human eye directly, or indirectly, can cause permanent damage. Do not look directly into the laser output port.