



## C15F-5A-C2G

### 1550nm FP Laser Diode TO-can with Ball Lens

#### Description

The Lasermate C15F-5A-C2G is a 1550nm wavelength, Fabry-Perot FP laser diode, TO-can, designed for use in telecommunication applications.

#### Features

- 1550nm InGaAsP/InP MQW-FP laser diode (LD)
- Uncooled and Hermetically sealed
- -40 to 85°C operating temperature
- High performance, high speed InGaAs monitor PIN photodiode (PD)
- Packaged in ball lens (2.0mm) TO-56 type

#### Applications

- SONET OC-12/OC-48
- SDH STM-4/STM-16
- Gigabit Ethernet
- Stable emitting source

#### Specifications

Absolute Maximum Ratings				
Parameters	Symbol	Value	Unit	Conditions
Storage temperature	Tstg	-40~+85	°C	
Operating case temperature	Top	-40~+85	°C	
Peak optical output power	Po	8	mW	
Forward current (LD)	I <sub>FLD</sub>	120	mA	
Reverse voltage (LD)	V <sub>RLD</sub>	2	V	
Reverse current (PD)	I <sub>RPD</sub>	2	mA	
Reverse voltage (PD)	V <sub>RPD</sub>	20	V	
Soldering temperature	Stemp	260	°C	10 seconds

Electro-Optical Characteristics (CW @ T <sub>c</sub> = 25°C unless otherwise noted)						
Parameters	Symbol	Min.	Typ.	Max.	Unit	Conditions
Threshold current	I <sub>th</sub>	—	10	15	mA	CW
Operating voltage	V <sub>op</sub>	—	1.1	1.5	V	CW, Pop=5mW
Operating current	I <sub>op</sub>	—	—	43	mA	Pop=5mW
Slope efficiency	η	0.20	0.28	—	mW/mA	CW, Pop=5mW
Peak wavelength	λ <sub>p</sub>	1515	1530	1550	nm	CW, Pop
Spectral width (RMS)	Δλ	—	2	3	nm	CW, Pop, K=1.0
Rise time	T <sub>r</sub>	—	—	200	ps	I <sub>b</sub> =I <sub>th</sub> , 20%~80%
Fall time	T <sub>f</sub>	—	—	200	ps	I <sub>b</sub> =I <sub>th</sub> , 20%~80%
Monitor current	I <sub>m</sub>	100	—	800	uA	Pop, V <sub>rp</sub> =5V
Monitor dark current	I <sub>d</sub>	—	—	100	nA	V <sub>rp</sub> = 5V
Monitor capacitance	C	—	6	10	pF	V <sub>rp</sub> = 5V, f=1MHZ
Focal Length	D <sub>f</sub>	6.2	6.5	6.8	mm	CW, P <sub>o</sub> =5mW, SMF

### Outline Dimensions (unit: mm)

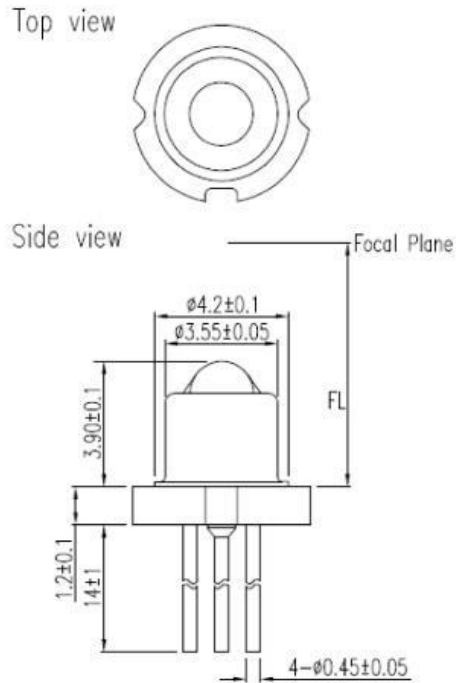

### Pin Assignment

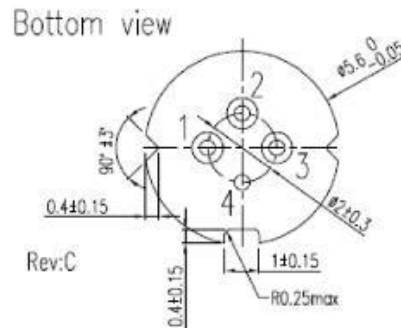

Pin Number	Function
1	LD Cathode
2	PD Anode
3	LD Anode, PD Cathode
4	Case

### Additional Notes

- Avoid eye or skin exposure to laser radiations.
- The device is sensitive to electro-static discharge (ESD). The device should be handled with ESD proof tools. To assemble the device on PCB, proper grounding is required to prevent ESD.
- Specifications are subject to change without notice.