



C13F-5A-C2G

1310nm FP Laser Diode TO-can with Ball Lens

Description

The Lasermate C13F-5A-C2G is a 1310nm wavelength, Fabry-Perot FP laser diode, TO-can, designed for use in telecommunication applications.

Features

- 1310nm InGaAsP/InP MQW-FP laser diode (LD)
- Uncooled and Hermetically sealed
- -40 to 85°C operating temperature
- High performance, high speed InGaAs monitor PIN photodiode (PD)
- Packaged in ball lens (2.0mm) TO-56 type

Applications

- SONET OC-12/OC-48
- SDH STM-4/STM-16
- Gigabit Ethernet
- Stable emitting source

Specifications

Absolute Maximum Ratings				
Parameters	Symbol	Value	Unit	Conditions
Storage temperature	Tstg	-40~+95	°C	
Operating case temperature	Top	-40~+85	°C	
Peak optical output power	Po	10	mW	
Forward current (LD)	I _{FLD}	120	mA	
Reverse voltage (LD)	V _{RLD}	2	V	
Reverse current (PD)	I _{RPD}	2	mA	
Reverse voltage (PD)	V _{RPD}	15	V	
Soldering temperature	Stemp	260	°C	10 seconds

Electro-Optical Characteristics (CW @ T _c = 25°C unless otherwise noted)						
Parameters	Symbol	Min.	Typ.	Max.	Unit	Conditions
Threshold current	I _{th}	—	9	13	mA	CW
Operating voltage	V _{op}	—	1.1	1.6	V	CW, Pop=5mW
Operating current	I _{op}	—	—	30	mA	Pop=5mW
Slope efficiency	η	0.35	—	—	mW/mA	CW, Pop=5mW
Peak wavelength	λ _p	1290	1310	1330	nm	CW, Pop
Spectral width (RMS)	Δλ	—	—	2.5	nm	CW, Pop, K=1.0
Fiber Coupling Power	P _f	1.0	—	—	mW	CW, P _o =5mW, SMF (10/125)
Focal Length	D _f	6.2	6.5	6.8	mm	CW, P _o =5mW, SMF (10/125)
Rise time	T _r	—	80	120	ps	I _b =I _{th} , 20%~80%
Fall time	T _f	—	100	150	ps	I _b =I _{th} , 20%~80%
Monitor current	I _m	70	—	800	uA	Pop, V _{rp} =5V
Monitor dark current	I _d	—	—	100	nA	V _{rp} = 5V
Monitor capacitance	C	—	—	15	pF	V _{rp} = 5V, f=1MHZ

Outline Dimensions (unit: mm)

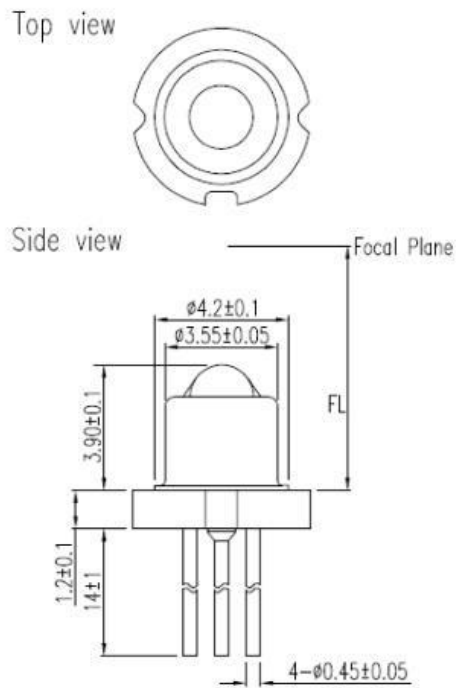

Pin Assignment

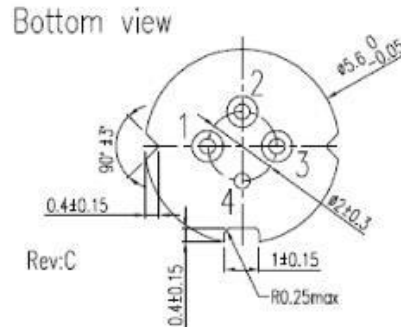

Pin Number	Function
1	LD Cathode
2	PD Anode
3	LD Anode, PD Cathode
4	Case

Additional Notes

- Avoid eye or skin exposure to laser radiations.
- The device is sensitive to electro-static discharge (ESD). The device should be handled with ESD proof tools. To assemble the device on PCB, proper grounding is required to prevent ESD.
- Specifications are subject to change without notice.