



VCCA4-85A14G

14Gb/s 850nm VCSEL Chip 1x4 Array

Description

The Lasermate VCCA4-85C14G is an 850nm wavelength, Vertical Cavity Surface Emitting Laser (VCSEL) chip array with 4 channels. The VCSEL chip array is designed for use in 14Gbps data rate operation.

Features

- Multi-mode 850nm VCSEL chip array
- High data rate up to 14Gbps
- 1x4 chip array
- Two top-side wire bond pads

Applications

- High speed Data communications
- Gigabit ethernet
- Fiber channel

Specifications

Absolute Maximum Ratings					
Parameters	Min.	Max.	Unit	Conditions	
Storage Temperature	-40	100	°C		
Operating Temperature	0	85	°C		
Continuous Forward Current		10	mA		
Continuous Reverse Voltage		5	V	10uA	

Electro-Optical Characteristics (T _a =25°C unless otherwise stated)						
Parameters	Symbol	Min.	Typ.	Max.	Unit	Conditions
Threshold Current	I _{th}		0.6	1.2	mA	CW
I _{th} Uniformity within Array	ΔI _{th} ^a			0.2	mA	CW
Slope Efficiency	η		0.5		W/A	I _f =6mA
Optical Output Power	P _o		3.0		mW	I _f =6mA
P _o Uniformity within Array	ΔP _o ^a			0.3	mW	I _f =6mA
Peak Wavelength	λ _p	840	850	860	nm	I _f =6mA at room temperature
Spectral Bandwidth (RMS)	Δλ			0.5	nm	I _f =6mA
Beam Divergence	Θ	14		30	°	I _f =6mA, (Full Width, 1/e ²)
Forward Voltage	V _f		2.2	2.5	V	I _f =6mA
Breakdown Voltage	V _b		-10		V	
Dynamic Resistance	R _d		80	100	Ohm	I _f =6mA
Small Signal Bandwidth	f _{-3dB}		12		GHz	I _f =6mA

Thermal Characteristics						
Parameters	Symbol	Min.	Typ.	Max.	Unit	Conditions
I _{th} Temperature Variation	ΔI _{th}		1.5		mA	T _a =0 to 85°C
η Temperature Coefficient	Δη/ΔT		-0.5		%/°C	T _a =0 to 85°C, I _f =6mA
λ Temperature Coefficient	Δλ/ΔT		0.06		nm/°C	T _a =0 to 85°C, I _f =6mA

Outline Dimensions

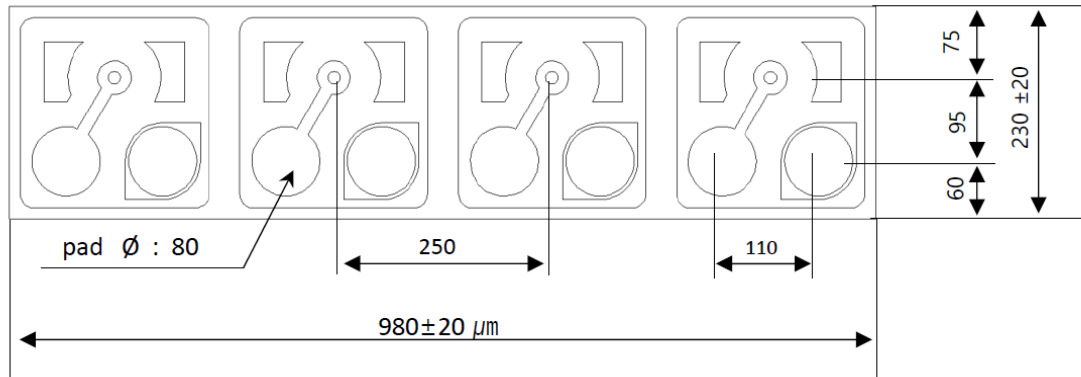

unit : μ m

Die Height : 150 \pm 15 μ m

Additional Notes

- The inherent design of this component causes it to be sensitive to electrostatic discharge (ESD). To prevent ESD-induced damage and/or degradation to equipment, take normal ESD precautions when handling this product.
- Specifications are subject to change without notice.