



T80E-XYZ-WM

808nm Single Mode Fiber Pigtailed Laser Diode, 9/125um SM Fiber, Multimode Beam



Description

The Lasermate T80E-XYZ-WM is an 808nm wavelength, fiber coupled laser diode offering up to 20mW output power through a 9/125um single mode fiber. The laser is designed for use in light source applications.

Features

- 808nm laser diode
- Operation at -10°C to +50 °C
- Built-in monitor photodiode
- Fiber optical output power >1mW and >20mW for 9/125um SM fiber

Packaging

- Fiber pigtailed with optional FC/SC/ST connector

Applications

- Light source

Product Overview

The following table lists the available part numbers, as well as the package, connector, output power, and optional mount of each of the part numbers.

Part Number	Package	Connector	Output Power	Pinout Configuration	Mount
T80E-PSC1-20	Pigtailed with 9/125um SM fiber	SC/PC	1mW	Common anode	No flange
T80E-PST1-20	Pigtailed with 9/125um SM fiber	ST/PC	1mW	Common anode	No flange
T80E-PFC1-20	Pigtailed with 9/125um SM fiber	FC/PC	1mW	Common anode	No flange
T80E-PSC1-21	Pigtailed with 9/125um SM fiber	SC/PC	1mW	Common anode	Horizontal mount
T80E-PST1-21	Pigtailed with 9/125um SM fiber	ST/PC	1mW	Common anode	Horizontal mount
T80E-PFC1-21	Pigtailed with 9/125um SM fiber	FC/PC	1mW	Common anode	Horizontal mount
T80E-PSC20-20	Pigtailed with 9/125um SM fiber	SC/PC	20mW	Common anode	No flange
T80E-PST20-20	Pigtailed with 9/125um SM fiber	ST/PC	20mW	Common anode	No flange
T80E-PFC20-20	Pigtailed with 9/125um SM fiber	FC/PC	20mW	Common anode	No flange
T80E-PSC20-21	Pigtailed with 9/125um SM fiber	SC/PC	20mW	Common anode	Horizontal mount
T80E-PST20-21	Pigtailed with 9/125um SM fiber	ST/PC	20mW	Common anode	Horizontal mount
T80E-PFC20-21	Pigtailed with 9/125um SM fiber	FC/PC	20mW	Common anode	Horizontal mount

Specifications

Absolute Maximum Ratings (T _c = 25°C)			
Parameter	Symbol	Rating	Unit
Operating Temperature	T _{op}	-10 to +50	°C
Storage Temperature	T _{stg}	-40 to +85	°C
LD Reverse Voltage	V _{RLD}	2	V
PD Reverse Voltage	V _{RPD}	30	V

Electrical-Optical Characteristics (T _c = 25°C)							
Parameter	Symbol	Min.	Typ.	Max	Unit	Conditions	
Lasing Wavelength	λ	800	808	820	nm		
Threshold current	For 1mW	I _{th}	-	25	-	mA	CW
	For 20mW		-	50	-		
Operating current	For 1mW	I _{op}	-	35	-	mA	
	For 20mW		-	120	-		
Operating voltage	For 1mW	V _{op}	-	2.2	2.5	Volt	
	For 20mW		-	2.0	2.4		
Optical output power	For 1mW	P _o	1			mW	9/125 μm SM fiber
	For 20mW		20				
Monitor current	I _m	10	-	500	μA		

Pin Configuration

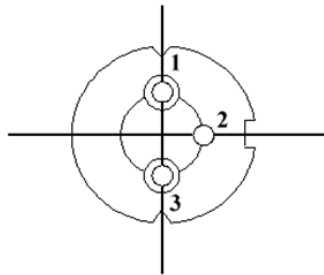

Bottom View

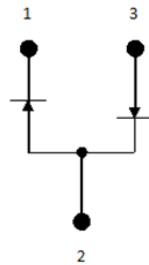

Pin	Function
1	Laser Diode Cathode
2	Laser Diode Anode, Photodiode Cathode
3	Photodiode Anode

Mechanical Outline (unit: mm)

Laser Diode

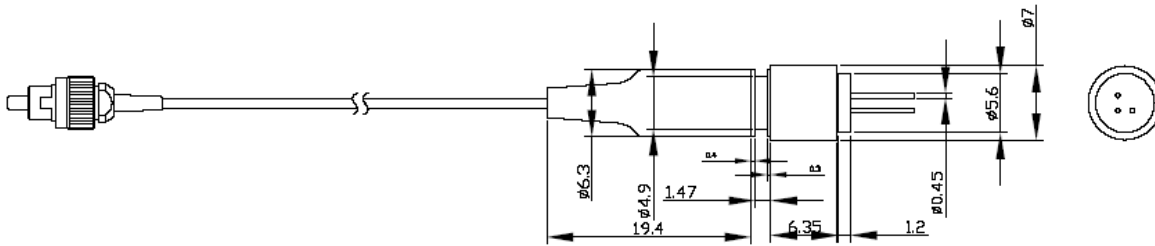

Horizontal Mount

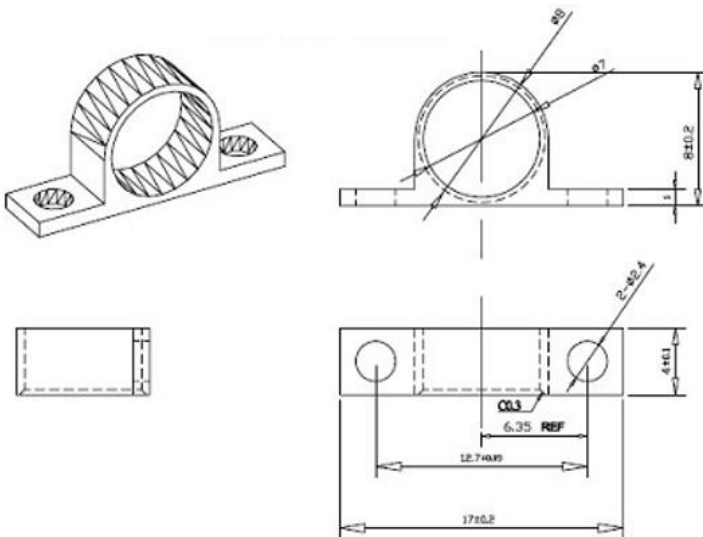

Additional Notes

- The laser diodes are designated solely as OEM components for incorporation into the customer's end products. Therefore, it is the customer's responsibility to comply with the appropriate requirements of FDA 21CFR, section 1040.10 and 1040.11 for complete laser products. For the code of FDA regulations, please refer to [FDA Performance Standards for Light-Emitting Products](#) for detailed information.
- Specifications are subject to change without notice.