



T63E-XYZ-WM

635nm Single Mode Fiber Pigtailed Laser Diode, 9/125um SM Fiber, Multimode Beam



Description

The Lasermate T63E-XYZ-WM is a 635nm wavelength, fiber coupled laser diode offering up to 2mW output power through a 9/125um SM fiber. The laser is designed for use in optical fiber checker and light source applications.

Features

- 635nm laser diode
- Operation at -10°C to +50°C
- Built-in monitor photodiode
- Fiber optical output power >1mW and >2mW for 9/125um SM fiber
- Common anode pinout

Packaging

- Fiber pigtailed with optional FC/SC/ST connector

Applications

- Design for optical fiber checker
- Light source

Product Overview

The following table lists the available part numbers, as well as the package, connector, output power, and optional mount of each of the part numbers.

Part Number	Package	Connector	Output Power	Pinout Configuration	Mount
T63E-PSC1-20	Pigtailed with 9/125um SM fiber	SC/PC	1mW	Common anode	No flange
T63E-PST1-20	Pigtailed with 9/125um SM fiber	ST/PC	1mW	Common anode	No flange
T63E-PFC1-20	Pigtailed with 9/125um SM fiber	FC/PC	1mW	Common anode	No flange
T63E-PSC1-21	Pigtailed with 9/125um SM fiber	SC/PC	1mW	Common anode	Horizontal mount
T63E-PST1-21	Pigtailed with 9/125um SM fiber	ST/PC	1mW	Common anode	Horizontal mount
T63E-PFC1-21	Pigtailed with 9/125um SM fiber	FC/PC	1mW	Common anode	Horizontal mount
T63E-PSC2-20	Pigtailed with 9/125um SM fiber	SC/PC	2mW	Common anode	No flange
T63E-PST2-20	Pigtailed with 9/125um SM fiber	ST/PC	2mW	Common anode	No flange
T63E-PFC2-20	Pigtailed with 9/125um SM fiber	FC/PC	2mW	Common anode	No flange
T63E-PSC2-21	Pigtailed with 9/125um SM fiber	SC/PC	2mW	Common anode	Horizontal mount
T63E-PST2-21	Pigtailed with 9/125um SM fiber	ST/PC	2mW	Common anode	Horizontal mount
T63E-PFC2-21	Pigtailed with 9/125um SM fiber	FC/PC	2mW	Common anode	Horizontal mount



Technical Specifications

Absolute Maximum Ratings (T _c = 25°C)			
Parameter	Symbol	Rating	Unit
Operating Temperature	T _{op}	-10 to +50	°C
Storage Temperature	T _{stg}	-40 to +85	°C
LD Reverse Voltage	V _{RLD}	2	V
PD Reverse Voltage	V _{RPD}	30	V

Electrical-Optical Characteristics (T _c = 25°C)							
Parameter	Symbol	Min.	Typ.	Max	Unit	Conditions	
Lasing Wavelength	λ	625	635	645	nm		
Threshold current	For 1mW	I _{th}	-	26	40	mA	CW
	For 2mW		-	35	-		
Operating current	For 1mW	I _{op}	-	30	-	mA	
	For 2mW		-	50	-		
Operating voltage	V _{op}	-	2.0	2.5	Volt		
Optical output power	For 1mW	P _o	1			mW	9/125 μm SM fiber
	For 2mW		2				
Monitor current	I _m	50	110	500	μA		

Pin Configuration

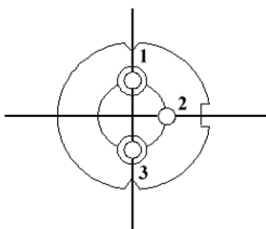

Bottom View

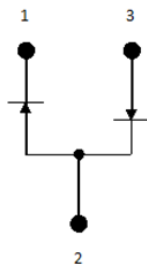

Pin	Function
1	Laser Diode Cathode
2	Laser Diode Anode, Photodiode Cathode
3	Photodiode Anode

Mechanical Outline (unit: mm)

Laser Diode

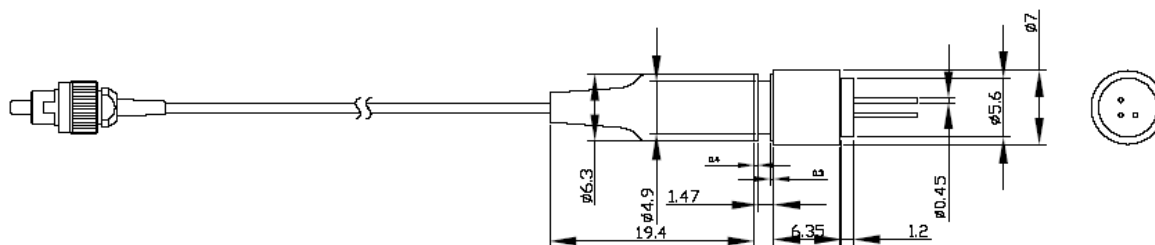

Horizontal Mount

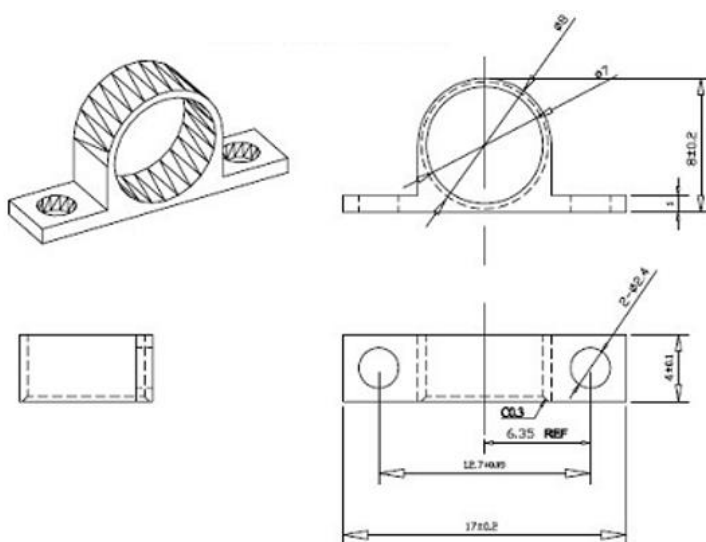

Additional Notes

- The laser diodes are designated solely as OEM components for incorporation into the customer's end products. Therefore, it is the customer's responsibility to comply with the appropriate requirements of FDA 21CFR, section 1040.10 and 1040.11 for complete laser products. For the code of FDA regulations, please refer to [FDA Performance Standards for Light-Emitting Products](#) for detailed information.
- Specifications are subject to change without notice.