



LD980-2W3x

High Power 980nm 2000mW FP Laser Diode in TO3 Package

Description

The Lasermate LD-980-2W3x is a high power 980nm, 2000mW Fabry-Perot laser diode in TO3 package. The laser diode is suitable as laser light source for many applications.

Features

- 980nm Infrared laser diode
- Optical output power: 2000mW CW
- High output power
- No monitor photodiode
- Package: TO3

Applications

- Solid-state laser pumping
- Medical usage
- Infrared sources for night vision
- Information recognition

Product Overview

| PART NUMBER | PACKAGE STYLE |
|-------------|----------------------------------|
| LD-980-2W3 | TO3 with removable metal cap |
| LD-980-2W3N | TO3 with non-removable metal cap |

Specifications (T_c = 25°C)

| PARAMETER | TYP. | UNIT |
|--|--------|-------|
| CW Output Power | 2000 | mW |
| Peak Wavelength λ | 980±10 | nm |
| Spectral Width $\Delta\lambda$ | ≤3 | nm |
| Threshold Current | ≤0.50 | A |
| Operating Current | ≤2.56 | A |
| Operating Voltage | ≤2.0 | V |
| Slope Efficiency | ≥0.90 | W/A |
| Beam Divergence $\theta_{\perp} \times \theta_{\parallel}$ | 40×10 | deg |
| Wavelength Temperature Coefficient | 0.4 | nm/°C |
| Emitting Area | 150×1 | μm |
| Series Resistance | ≤0.25 | Ω |
| Polarization | TE | |
| Package Style | TO3 | |

Absolute Maximum Ratings

| PARAMETER | TYP. | UNIT |
|-----------------------|-----------|------|
| Operating Temperature | 10 to 25 | °C |
| Storage Temperature | -10 to 60 | °C |
| Reverse Voltage | 2.0 | V |

Typical Characteristics

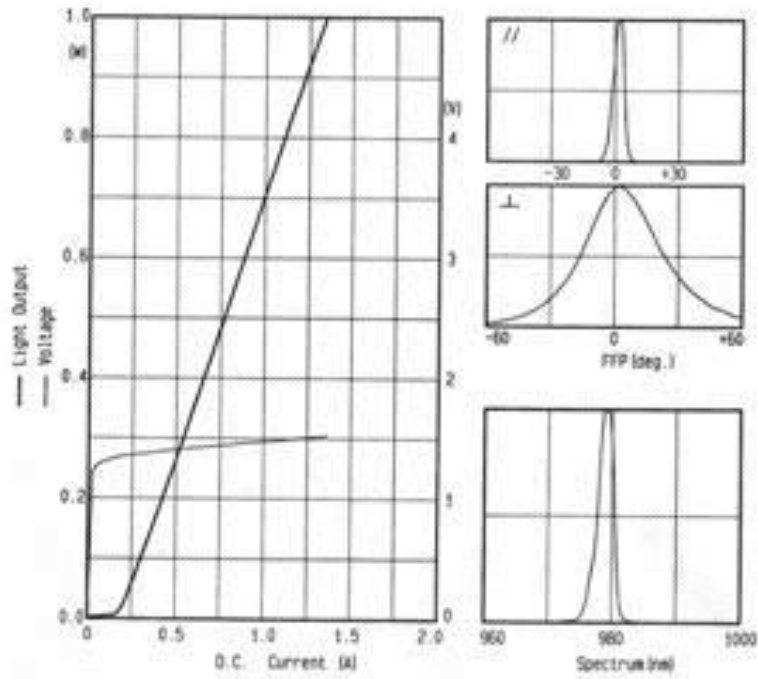

Mechanical Outline (unit: mm)

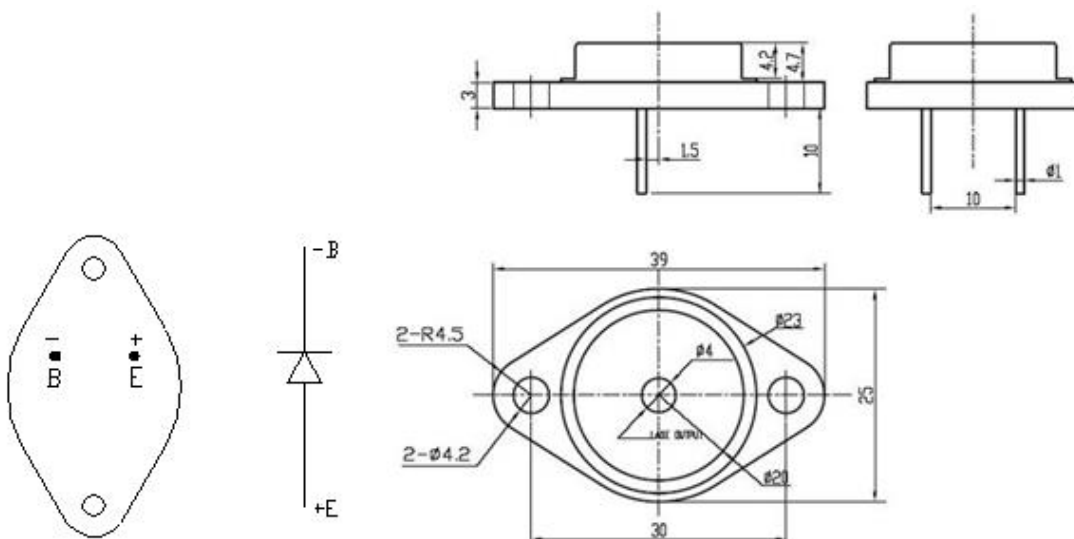



Additional Notes

- High power laser diodes are high energy laser devices. It is harmful to human body and health. Never look directly into the laser output port.
- High power laser diodes could operate in forward voltage. The reverse current and voltage should not be higher than 25 μ A and 3 V, respectively.
- Heavy humidity can get dew on the LD then damage the LD.
- The generated heat must be removed in time when the LD is working.
- The high temperature will affect the performance of the products. The lifetime can also be shortened by high temperature.
- The operating current and optical power of laser must not be higher than the given rate current and power. The excessive current would accelerate aging and shorten lifetime, even damage the LD.
- The semiconductor laser diode is a sensitive electronic device. Please observe precaution for handling electrostatic sensitive devices.
- Specifications are subject to change without notice. Ensure that you have the latest specification by contacting us prior to purchase or use of the product.