



## LD850A5C15

850nm 5mW 50°C CW Laser Diode in  $\varnothing$ 5.6mm TO-18 Can Package

## Description

The Lasermate LD850A5C15 is an 850nm, 5mW laser diode in a  $\varnothing$ 5.6mm, TO-can package and with operating temperature of 50°C. The laser diode is suitable as compact light source for many applications.

## Features

- 850nm Infrared laser diode
- Optical output power: 5mW CW
- Operating temperature: +50°C
- Low operation current
- Cost effective
- Package: TO-18 (dia. 5.6mm)

## Applications

- Bar code scanner
- Laser printer
- Military

## Absolute Maximum Ratings

PARAMETER	SYMBOL	RATING	UNIT
Optical output power	$P_O$	5	mW
Reverse voltage (LD)	$V_{RL}$	3.5	V
Reverse voltage (PD)	$V_{RD}$	30	V
Forward current (PD)	$I_{FD}$	10	mA
Operating temperature	$T_{opr}$	-10 to +50	°C
Storage temperature	$T_{stg}$	-40 to +85	°C

Electrical and Optical Characteristics ( $T_C = 25^\circ\text{C}$ )

PARAMETER	SYMBOL	MIN.	TYP.	MAX.	UNIT	CONDITIONS
Peak wavelength	$\lambda$	840	845	850	nm	$P_O = 5\text{mW}$
Threshold current	$I_{th}$	-	19	25	mA	
Operating current	$I_{op}$	-	26	35	mA	$P_O = 5\text{mW}$
Operating voltage	$V_{op}$	-	1.8	2.0	V	$P_O = 5\text{mW}$
Slope efficiency	$\eta$	0.5	0.9	1.1	mW/mA	$P_O = 3\text{-}5\text{mW}$
Monitor current	$I_m$	0.2	0.5	0.8	mA	$P_O = 5\text{mW}, V_{RD} = 5\text{V}$
Parallel divergence angle	$\Theta_{//}$	6	9	14	deg	$P_O = 5\text{mW}$
Perpendicular divergence angle	$\Theta_{\perp}$	27	32	36	deg	$P_O = 5\text{mW}$
Parallel FFP deviation angle	$\Delta \Theta_{//}$	-3	0	3	deg	$P_O = 5\text{mW}$
Perpendicular FFP deviation angle	$\Delta \Theta_{\perp}$	-3	0	3	deg	$P_O = 5\text{mW}$
Emission point accuracy	$\Delta x \Delta y$	-80	0	80	um	$P_O = 5\text{mW}$
Emission point accuracy	$\Delta z$	-40	0	40	um	$P_O = 5\text{mW}$



### Typical Characteristics

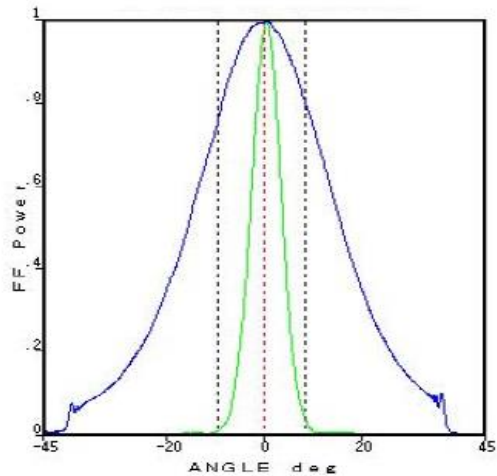
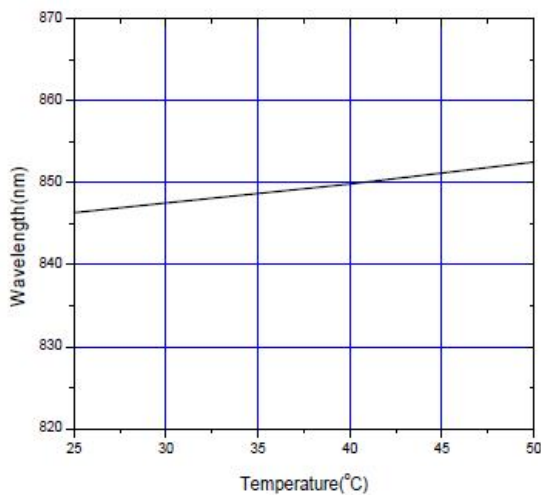
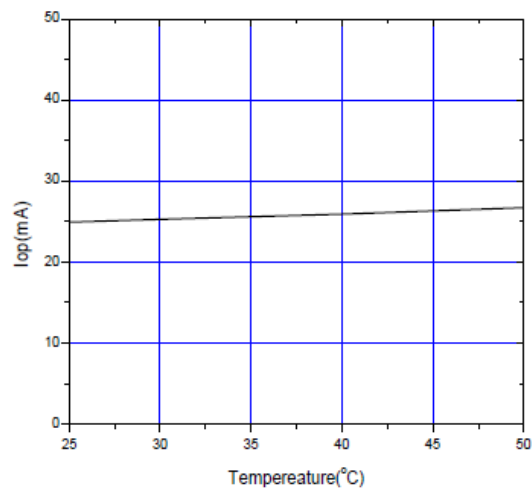
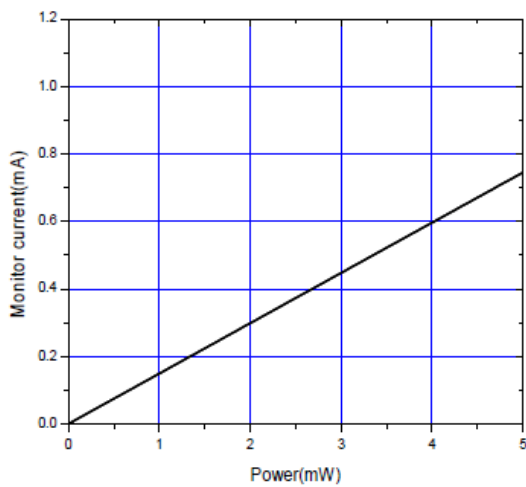
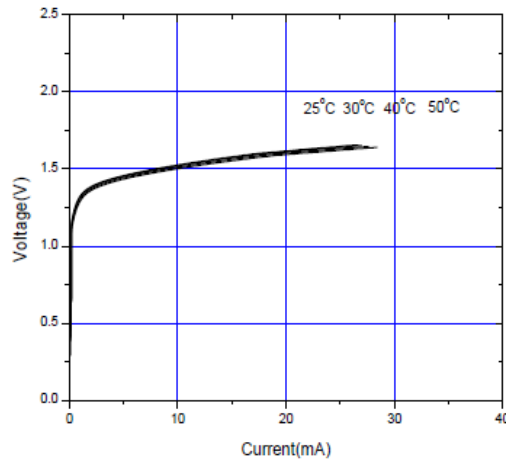
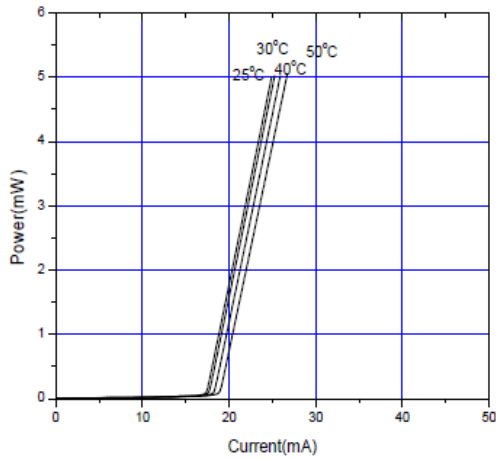

Mechanical Outline (unit: mm)

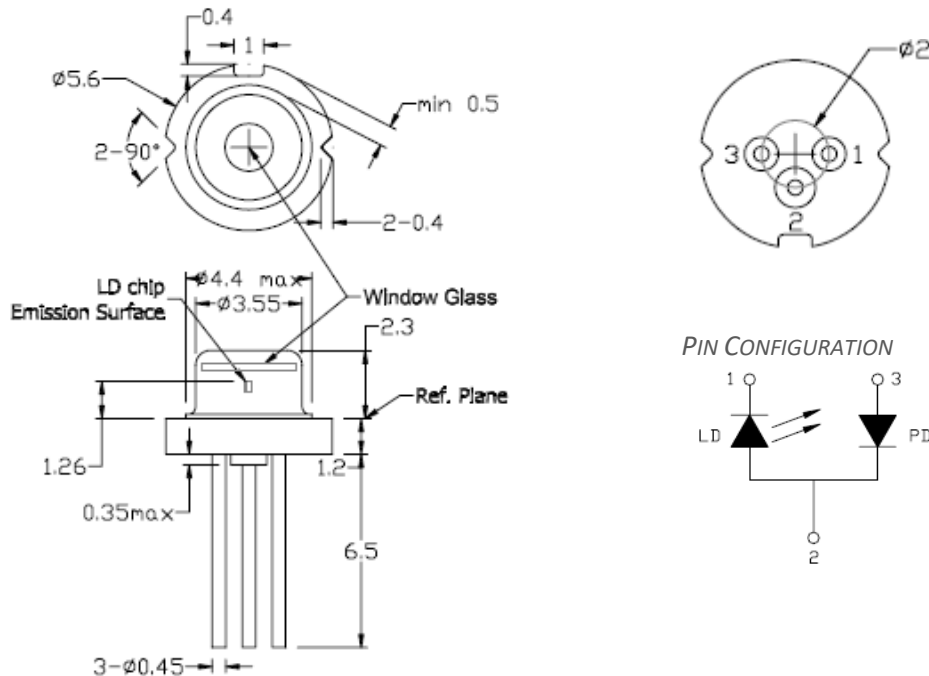

Additional Notes

- Do not operate the device above maximum ratings. Doing so may cause unexpected and permanent damage to the device.
- Take precautions to avoid electrostatic discharge and/or momentary power spikes. A change in the characteristics of the laser or premature failure may result.
- Proper heat sinking of the device assures stability and lifetime. Always ensure that maximum operating temperatures are not exceeded.
- Observing visible or invisible laser beams with human eye directly, or indirectly, can cause permanent damage. Use a camera to observe the laser.
- No laser device should be used in any application or situation where life or property is at risk in the event of device failure.
- Specifications are subject to change without notice. Ensure that you have the latest specification by contacting us prior to purchase or use of the product.