



LD830A100C16

830nm 100mW 60°C CW Laser Diode in ø5.6mm TO-18 Can Package

Description

The Lasermate LD830A100C16 is an 830nm, 100mW laser diode in a ø5.6mm, TO-can package and with operating temperature of 60°C. The laser diode is suitable as compact light source for many applications.

Features

- 830nm AlGaAs Infrared laser diode
- Optical output power: 100mW CW
- Operating temperature: +60°C
- High temperature operation
- Small far field angle
- Built-in photodiode for monitoring laser diode
- Package: TO-18 (dia. 5.6mm)

Applications

- Light source for sensor
- Industry

Absolute Maximum Ratings

PARAMETER	SYMBOL	CONDITION	RATING	UNIT
Optical output power	P_O	CW	110	mW
Reverse voltage (LD)	V_{RL}	-	2	V
Reverse voltage (PD)	V_{RD}	-	30	V
Forward current (PD)	I_{FD}	-	10	mA
Operating temperature	T_{opr}	-	-10 to +60	°C
Storage temperature	T_{stg}	-	-40 to +85	°C

Electrical and Optical Characteristics ($T_C = 25^\circ\text{C}$)

PARAMETER	SYMBOL	MIN.	TYP.	MAX.	UNIT	CONDITIONS
Lasing wavelength	λ_p	820	830	840	nm	$P_O = 100\text{mW}$
Threshold current	I_{th}	-	70	90	mA	$P_O = 100\text{mW}$
Operating current	I_{op}	-	180	200	mA	$P_O = 100\text{mW}$
Differential Efficiency	η	0.7	0.9	-	mW/mA	$P_O = 100\text{mW}$
Operating voltage	V_{op}	-	1.8	2.4	V	$P_O = 100\text{mW}$
Monitor current	I_m	-	0.8	-	mA	$P_O = 100\text{mW}, V_{RD} = 0\text{V}$
Parallel divergence angle	$\Theta_{//}$	5	8	12	deg	$P_O = 100\text{mW}$
Perpendicular divergence angle	Θ_{\perp}	-	15	20	deg	$P_O = 100\text{mW}$
Parallel FFP deviation angle	$\Delta \Theta_{//}$	-3	0	+3	deg	$P_O = 100\text{mW}$
Perpendicular FFP deviation angle	$\Delta \Theta_{\perp}$	-3	0	+3	deg	$P_O = 100\text{mW}$
Emission point accuracy	$\Delta x \Delta y \Delta z$	-80	0	+80	um	



Typical Characteristics

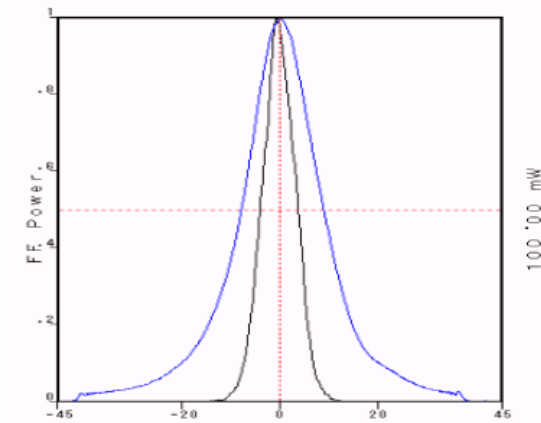
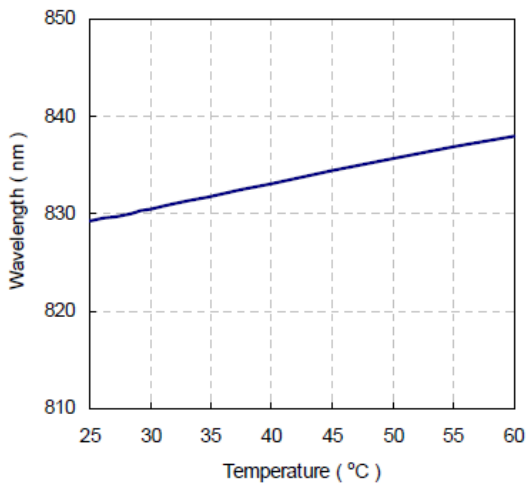
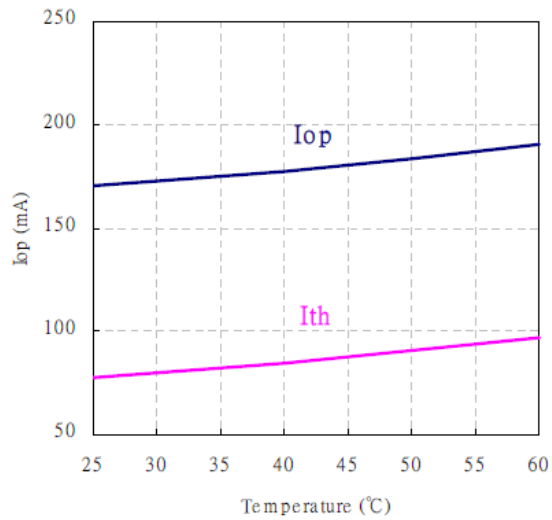
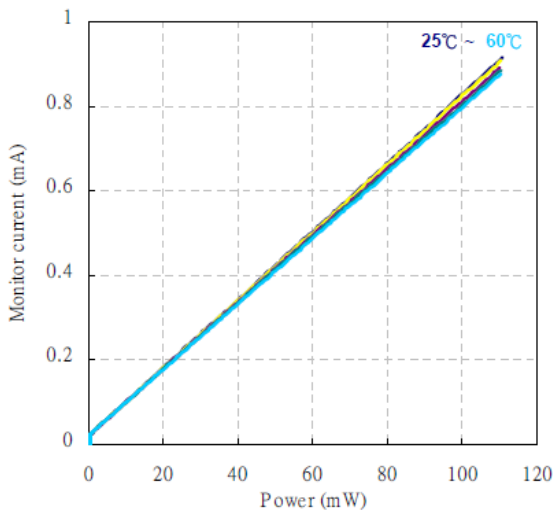
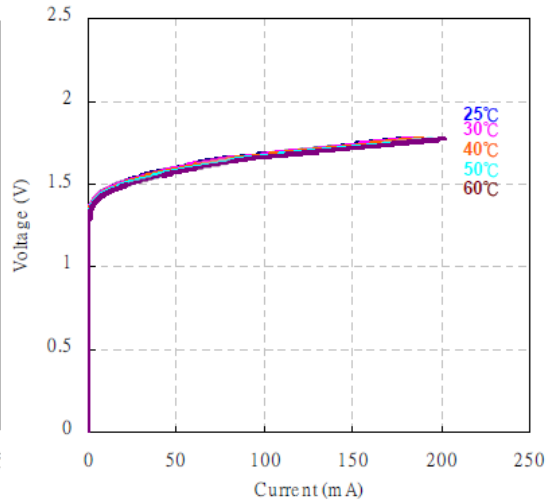
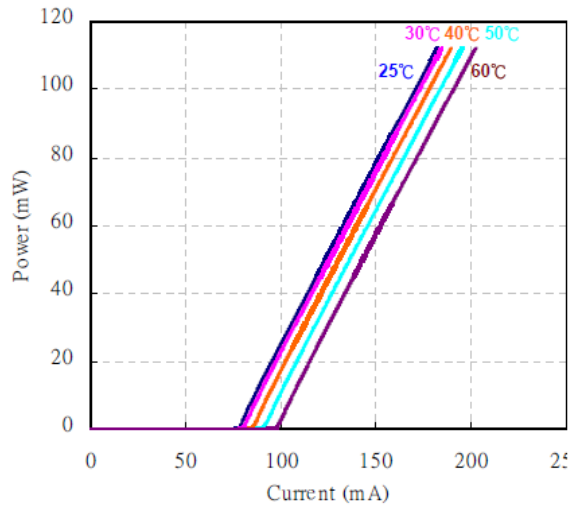

Mechanical Outline (unit: mm)

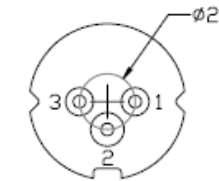
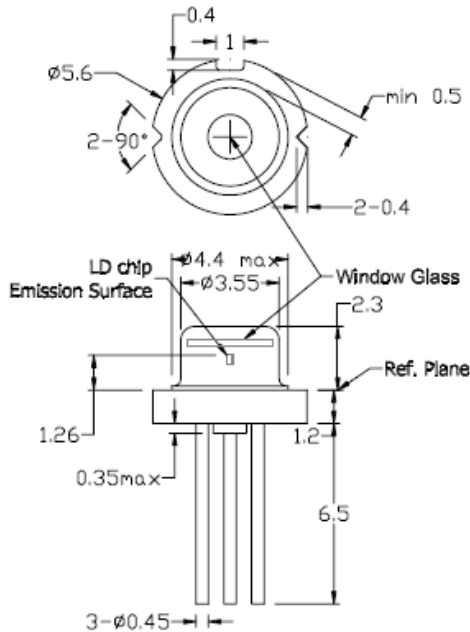

PIN CONFIGURATION

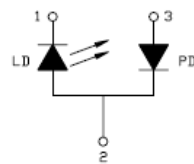

*Other pin configurations may be available upon request.

Additional Notes

- Do not operate the device above maximum ratings. Doing so may cause unexpected and permanent damage to the device.
- Take precautions to avoid electrostatic discharge and/or momentary power spikes. A change in the characteristics of the laser or premature failure may result.
- Proper heat sinking of the device assures stability and lifetime. Always ensure that maximum operating temperatures are not exceeded.
- Observing visible or invisible laser beams with human eye directly, or indirectly, can cause permanent damage. Use a camera to observe the laser.
- No laser device should be used in any application or situation where life or property is at risk in the event of device failure.
- Specifications are subject to change without notice. Ensure that you have the latest specification by contacting us prior to purchase or use of the product.