



LD808D5WF13

High Power 808nm 5000mW FP Laser Diode in TO3 Package

Description

The Lasermate LD808D5WF13 is a high power 808nm, 5000mW Fabry-Perot laser diode in TO3 package. The laser diode is suitable as laser light source for many applications.

Features

- 808nm Fabry-Perot cavity semiconductor laser
- Optical output power: 5000mW CW
- High output power
- No monitor photodiode
- Package: TO3

Specifications ($T_c = 20^\circ\text{C}$)

Optical Characteristics

PARAMETER	TYP.	UNIT
Lasing wavelength	808±5	nm
Output power	5	W
Spectral width	≤3	nm
Emitting area width	200	um
Temperature coefficient	0.30	nm/°C
Fast axis divergence	<40	deg
Slow axis divergence	<10	deg

Electrical Characteristics

PARAMETER	TYP.	UNIT
Slope efficiency	≥1.0	W/A
Threshold current	≤1.1	A
Operating current	≤5.5	A
Operating voltage	≤2.0	V

Others Characteristics

PARAMETER	TYP.	UNIT
Package	TO3	-
Operating temperature	15 to 30	°C
Storage temperature	-40 to +60	°C
Welding temperature	≤260	°C



Typical Characteristics

P-I-V CURVE

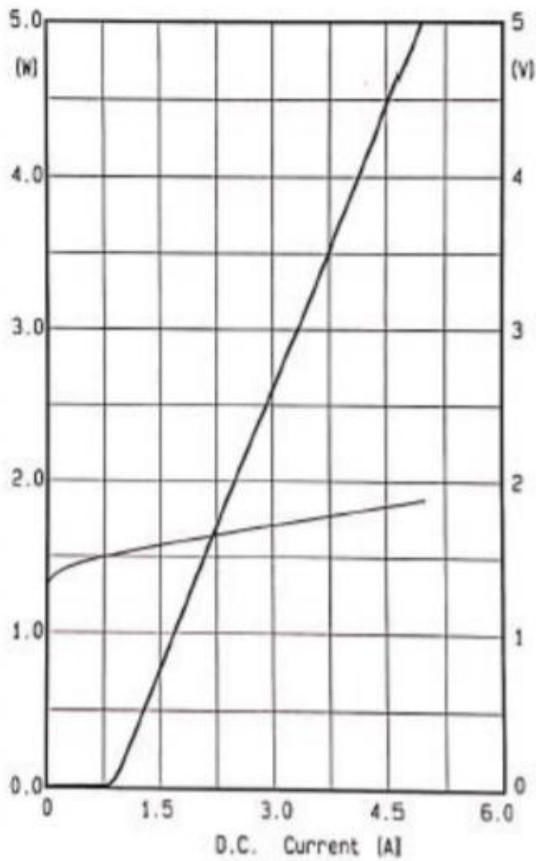

SPECTRAL CURVE

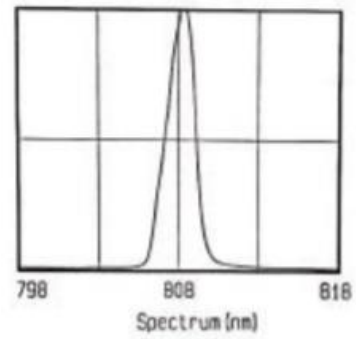

Mechanical Outline (unit: mm)

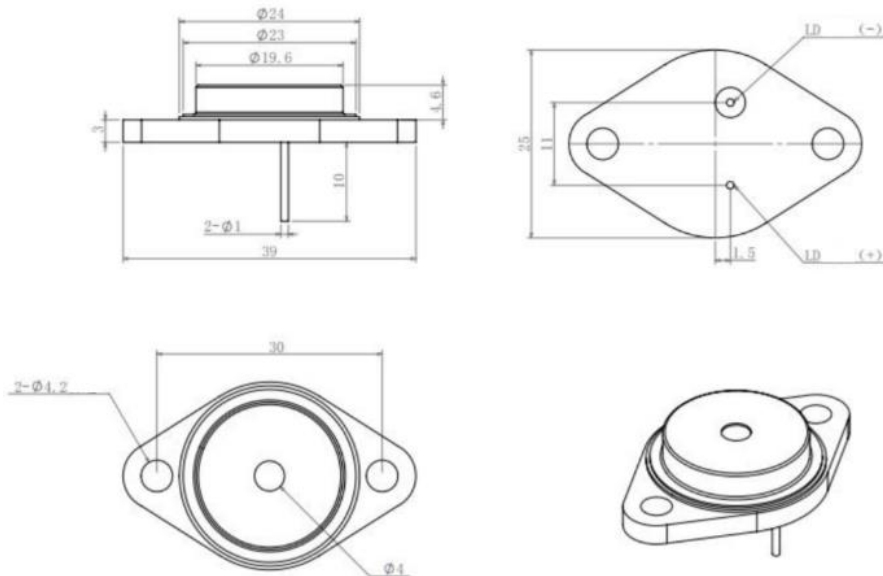

Additional Notes

- Data in the sheet are based on C-mount package heat sink testing.
- Do not operate the device above maximum ratings. Doing so may cause unexpected and permanent damage to the device.
- Take precautions to avoid electrostatic discharge and/or momentary power spikes. A change in the characteristics of the laser or premature failure may result.
- Proper heat sinking of the device assures stability and lifetime. Always ensure that maximum operating temperatures are not exceeded.
- Observing visible or invisible laser beams with human eye directly, or indirectly, can cause permanent damage. Use a camera to observe the laser.
- No laser device should be used in any application or situation where life or property is at risk in the event of device failure.
- Specifications are subject to change without notice. Ensure that you have the latest specification by contacting us prior to purchase or use of the product.