



## LD660A80C16

660nm 80mW 60°C CW Laser Diode in  $\varnothing$ 5.6mm TO-18 Can Package

## Description

The Lasermate LD660A80C16 is a 660nm, 80mW laser diode in a  $\varnothing$ 5.6mm, TO-can package and with operating temperature of 60°C. The laser diode is suitable as laser light source for many applications, including high power laser modules, medical applications, and industrial laser markers/measuring instruments.

## Features

- 660nm AlGaInP Visible Laser Diode
- Optical output power: 80mW CW
- High operating temperature: +60°C
- Highly reliable / COD level
- Higher power operation, High efficiency
- Built-in monitor PD
- Package: TO-18,  $\varnothing$ 5.6mm

## Applications

- High power laser modules
- Medical applications
- Industrial laser markers / measuring instruments

## Absolute Maximum Ratings

PARAMETER	SYMBOL	CONDITION	RATING	UNIT
Light output power	$P_O$	CW	85	mW
Reverse voltage (LD)	$V_{RL}$	-	2	V
Case temperature	$T_C$	-	-10 to +60	°C
Storage temperature	$T_S$	-	-40 to +85	°C

Electrical and Optical Characteristics ( $T_C = 25^\circ\text{C}$ )

PARAMETER	SYMBOL	MIN.	TYP.	MAX.	UNIT	CONDITIONS
Peak wavelength	$\lambda$	650	660	670	nm	$P_O = 80\text{mW}$
Threshold current	$I_{th}$	-	45	60	mA	$P_O = 80\text{mW}$
Operating current	$I_{op}$	-	120	150	mA	$P_O = 80\text{mW}$
Operating voltage	$V_{op}$	2.0	2.6	3.0	V	$P_O = 80\text{mW}$
Differential efficiency	$\eta$	0.7	1.0	1.4	mW/mA	$P_O = 70\text{-}80\text{mW}$
Monitor current	$I_m$	0.08	0.4	0.8	mA	$P_O = 80\text{mW}$ , $V_{RD} = 5\text{V}$
Parallel divergence angle	$\Theta_{//}$	6	9	13	deg	$P_O = 80\text{mW}$
Perpendicular divergence angle	$\Theta_{\perp}$	13	17	22	deg	
Parallel FFP deviation angle	$\Delta\Theta_{//}$	-3	-	+3	deg	
Perpendicular FFP deviation angle	$\Delta\Theta_{\perp}$	-3	-	+3	deg	
Emission point accuracy	$\Delta x \Delta y \Delta z$	-80	-	+80	um	



Typical Characteristics

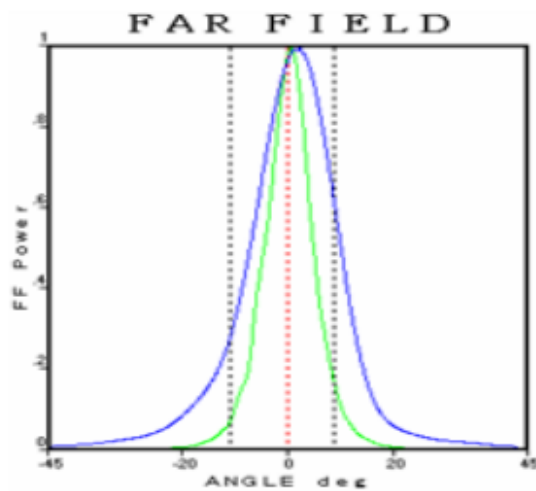
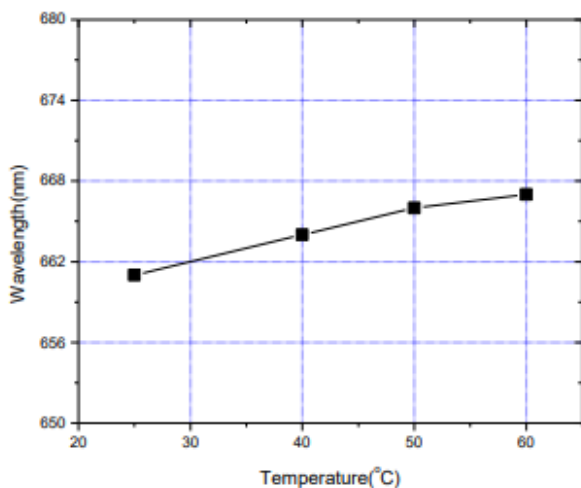
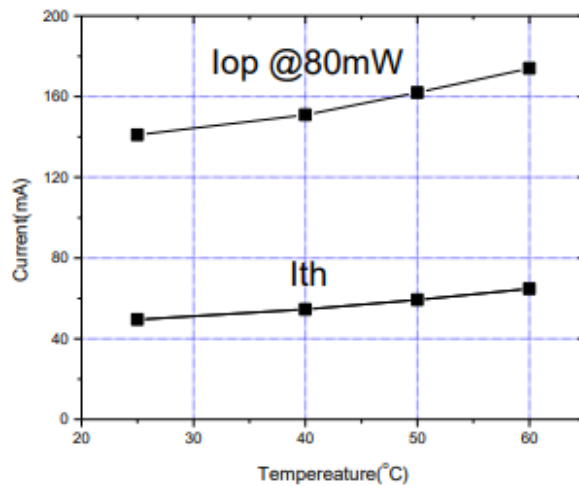
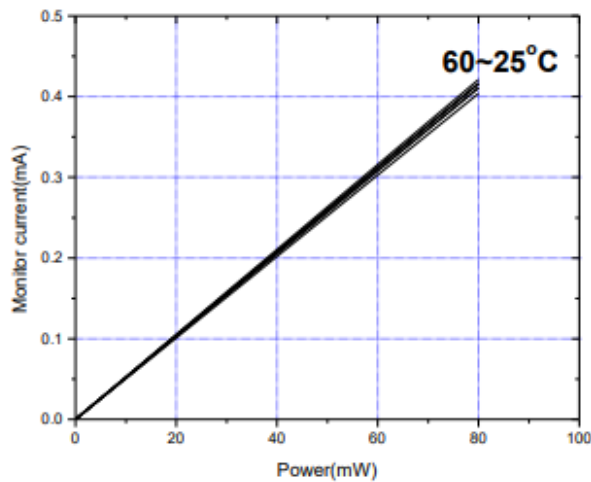
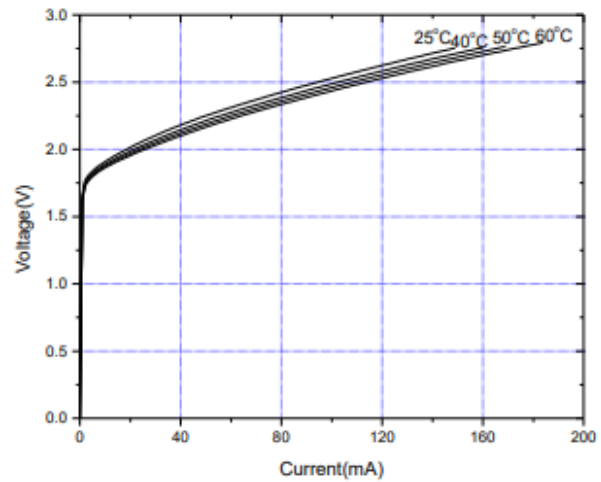
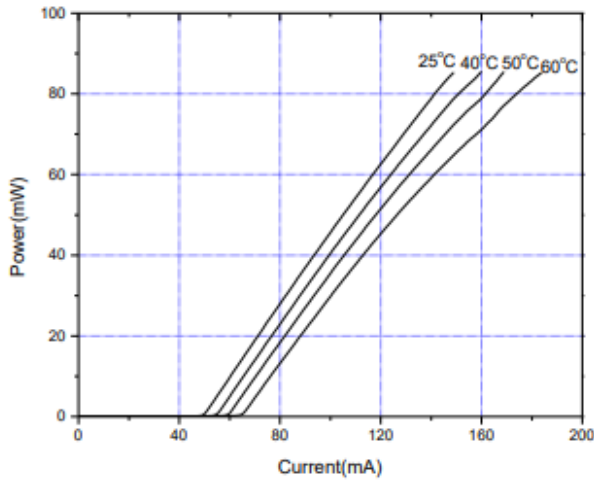

Mechanical Outline (unit: mm)

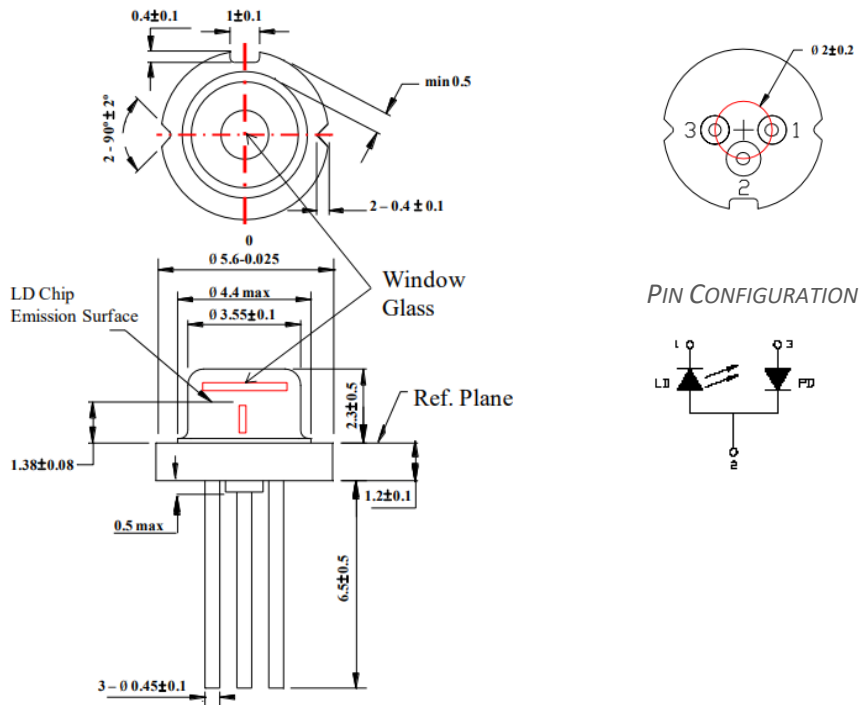

Additional Notes

- Do not operate the device above maximum ratings. Doing so may cause unexpected and permanent damage to the device.
- Take precautions to avoid electrostatic discharge and/or momentary power spikes. A change in the characteristics of the laser or premature failure may result.
- Proper heat sinking of the device assures stability and lifetime. Always ensure that maximum operating temperatures are not exceeded.
- Observing visible or invisible laser beams with human eye directly, or indirectly, can cause permanent damage. Use a camera to observe the laser.
- No laser device should be used in any application or situation where life or property is at risk in the event of device failure.
- Specifications are subject to change without notice. Ensure that you have the latest specification by contacting us prior to purchase or use of the product.