



## LD650A7C37

650nm 7mW 70°C CW Laser Diode in  $\varnothing$ 5.6mm TO-18 Can Package

## Description

The Lasermate LD650A7C37 is a 650nm, 7mW laser diode in a  $\varnothing$ 5.6mm, TO-18 can package and with wide operating temperature range of up to 70°C. The laser diode is suitable for many applications, including industry, consumer, and health fields.

## Features

- 650nm Visible Laser Diode
- Optical output power: 7mW CW
- High temperature operation: +70°C
- Single transverse mode
- TE mode
- Stable reliability
- Package: TO-18,  $\varnothing$ 5.6mm

## Applications

- Industry: Laser level, illumination, meter, scanner, detector
- Consumer: Point light, sweeper, game lighting
- Health: Special wavelength light source

## Specifications

ABSOLUTE MAXIMUM RATINGS				
PARAMETER	SYMBOL	CONDITION	RATING	UNIT
Light output power	$P_O$	CW	10	mW
Reverse voltage (LD)	$V_{RL}$	-	2	V
Reverse voltage (PD)	$V_{RD}$	-	30	V
Forward current (PD)	$I_{FD}$	-	10	mA
Case temperature	$T_C$	-	-30 to +70	°C
Storage temperature	$T_S$	-	-40 to +85	°C

ELECTRICAL AND OPTICAL CHARACTERISTICS ( $T_C = 25\text{ }^{\circ}\text{C}$ )						
PARAMETER	SYMBOL	MIN.	TYP.	MAX.	UNIT	CONDITIONS
Peak wavelength	$\lambda$	645	650	660	nm	$P_O = 7\text{mW}$
Threshold current	$I_{th}$	-	20	25	mA	
Operating current	$I_{op}$	-	27	35	mA	$P_O = 7\text{mW}$
Operating voltage	$V_{op}$	-	2.2	2.5	V	$P_O = 7\text{mW}$
Differential efficiency	$\eta$	0.7	1.0	1.2	mW/mA	$P_O = 3\text{-}5\text{mW}$
Monitor current	$I_m$	0.1	0.15	0.3	mA	$P_O = 7\text{mW}, V_{RD} = 5\text{V}$
Parallel divergence angle	$\Theta_{//}$	6	9	12	deg	$P_O = 7\text{mW}$
Perpendicular divergence angle	$\Theta_{\perp}$	25	28	32	deg	
Parallel FFP deviation angle	$\Delta \Theta_{//}$	-3	0	+3	deg	
Perpendicular FFP deviation angle	$\Delta \Theta_{\perp}$	-3	0	+3	deg	
Emission point accuracy	$\Delta x \Delta y \Delta z$	-80	0	+80	um	



Typical Characteristics

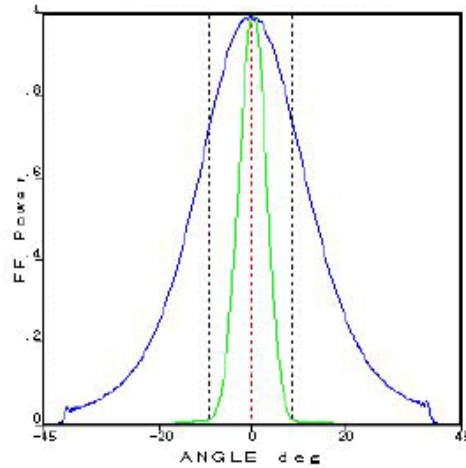
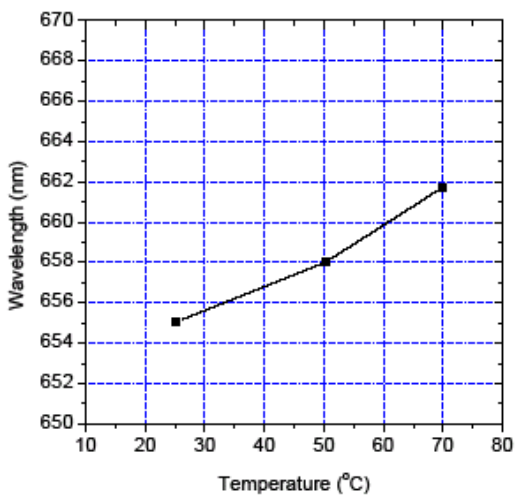
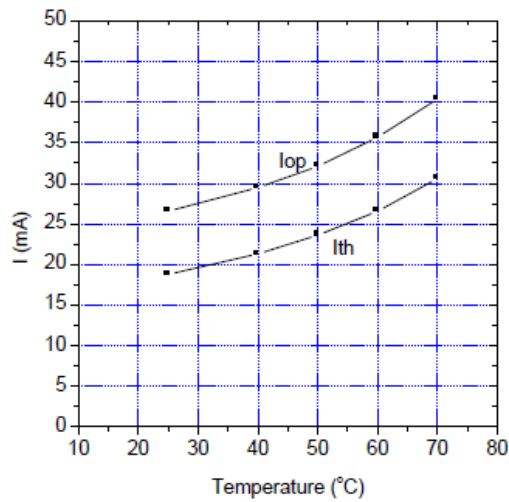
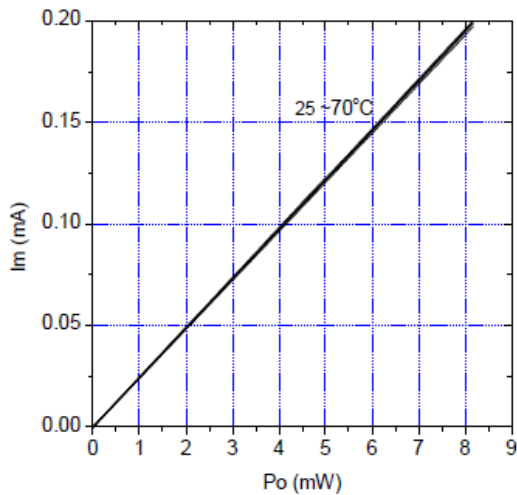
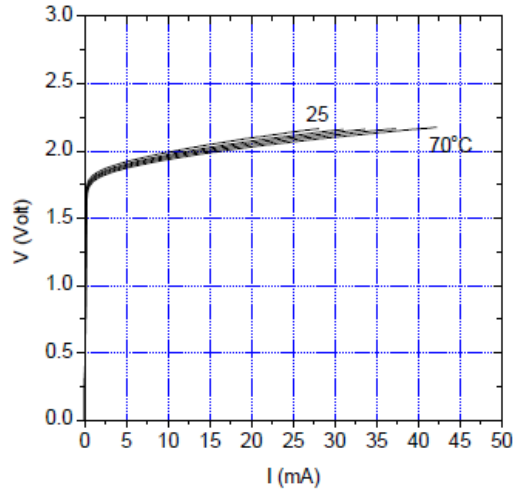
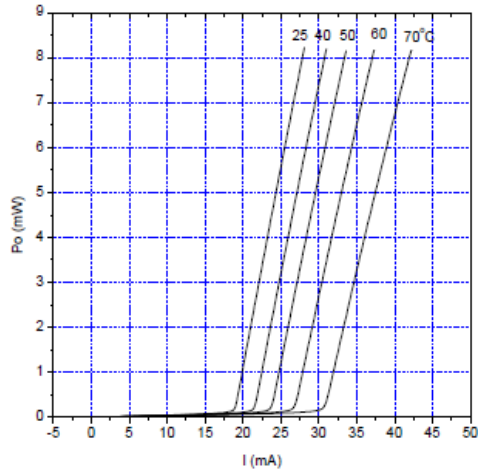

Mechanical Outline (unit: mm)

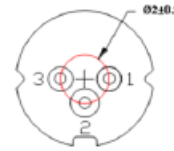
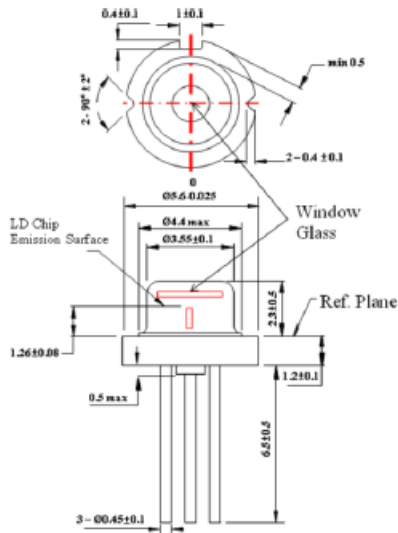

PIN CONFIGURATION

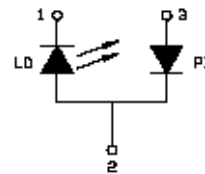

Additional Notes

- Do not operate the device above maximum ratings. Doing so may cause unexpected and permanent damage to the device.
- Take precautions to avoid electrostatic discharge and/or momentary power spikes. A change in the characteristics of the laser or premature failure may result.
- Proper heat sinking of the device assures stability and lifetime. Always ensure that maximum operating temperatures are not exceeded.
- Observing visible or invisible laser beams with human eye directly, or indirectly, can cause permanent damage. Use a camera to observe the laser.
- No laser device should be used in any application or situation where life or property is at risk in the event of device failure.
- Specifications are subject to change without notice. Ensure that you have the latest specification by contacting us prior to purchase or use of the product.