



LD650A10C15

650nm 10mW 50°C CW Laser Diode in \varnothing 5.6mm TO-18 Can Package

Description

The Lasermate LD650A10C15 is a 650nm, 10mW laser diode in a \varnothing 5.6mm, TO-18 can package and with operating temperature of 50°C. The laser diode is suitable as a light source for many applications, including laser levelers, industrial laser markers/measuring instruments, and bar code readers.

Features

- 650nm AlGaInP Visible Laser Diode
- Optical output power: 10mW CW
- Operating temperature: +50°C
- Better FFP performance
- High efficiency
- Package: TO-18, \varnothing 5.6mm

Applications

- Laser levelers
- Industrial laser markers / measuring instruments
- Bar code readers

Specifications

ABSOLUTE MAXIMUM RATINGS				
PARAMETER	SYMBOL	CONDITION	RATING	UNIT
Light output power	P_O	CW	13	mW
Reverse voltage (LD)	V_{RL}	-	2	V
Reverse voltage (PD)	V_{RD}	-	30	V
Forward current (PD)	I_{FD}	-	10	mA
Case temperature	T_C	-	-10 to +50	°C
Storage temperature	T_S	-	-40 to +85	°C

ELECTRICAL AND OPTICAL CHARACTERISTICS (TC = 25 °C)						
PARAMETER	SYMBOL	MIN.	TYP.	MAX.	UNIT	CONDITIONS
Peak wavelength	λ	645	650	660	nm	$P_O = 10\text{mW}$
Threshold current	I_{th}	-	20	25	mA	
Operating current	I_{op}	-	31	40	mA	$P_O = 10\text{mW}$
Operating voltage	V_{op}	-	2.2	2.5	V	$P_O = 10\text{mW}$
Differential efficiency	η	0.7	0.9	1.2	mW/mA	$P_O = 7\text{-}10\text{mW}$
Monitor current	I_m	0.1	0.3	0.4	mA	$P_O = 10\text{mW}, V_{RD} = 5\text{V}$
Parallel divergence angle	$\Theta_{//}$	6	9.5	12	deg	$P_O = 10\text{mW}$
Perpendicular divergence angle	Θ_{\perp}	25	28	32	deg	
Parallel FFP deviation angle	$\Delta \Theta_{//}$	-2	0	+2	deg	
Perpendicular FFP deviation angle	$\Delta \Theta_{\perp}$	-2	0	+2	deg	
Emission point accuracy	$\Delta x \Delta y \Delta z$	-80	0	+80	um	



Typical Characteristics

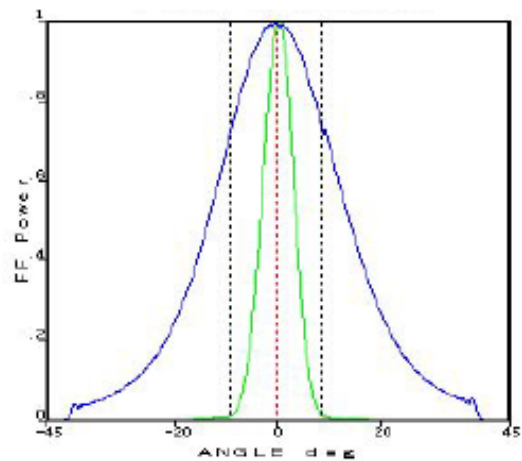
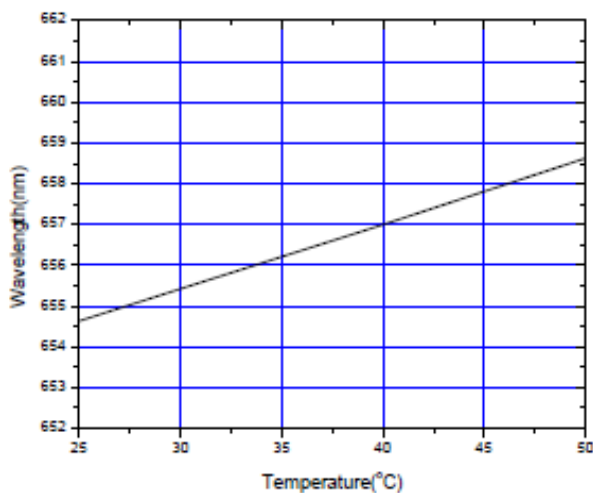
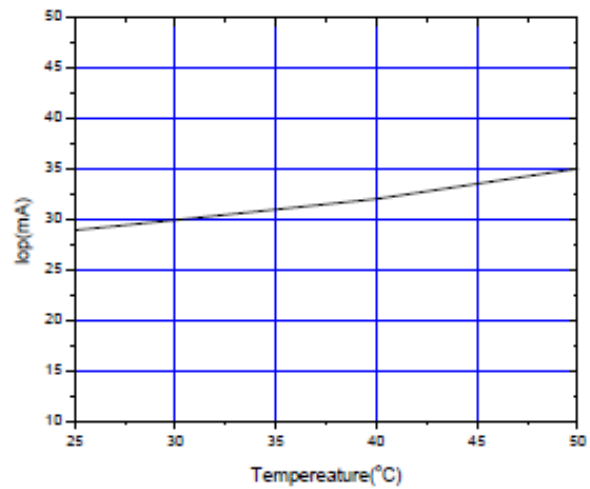
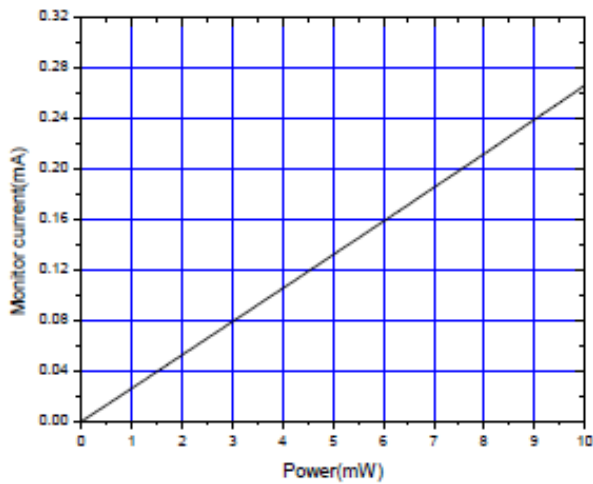
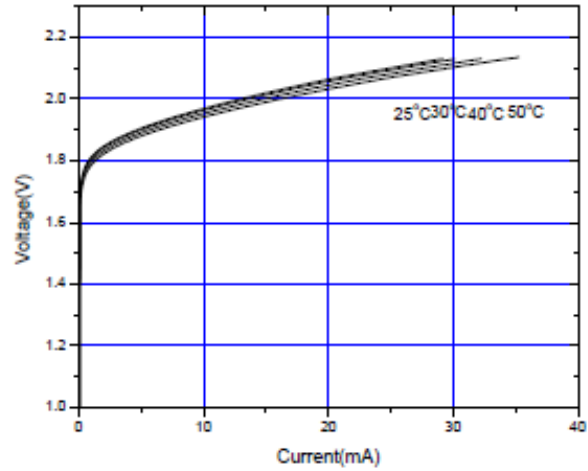
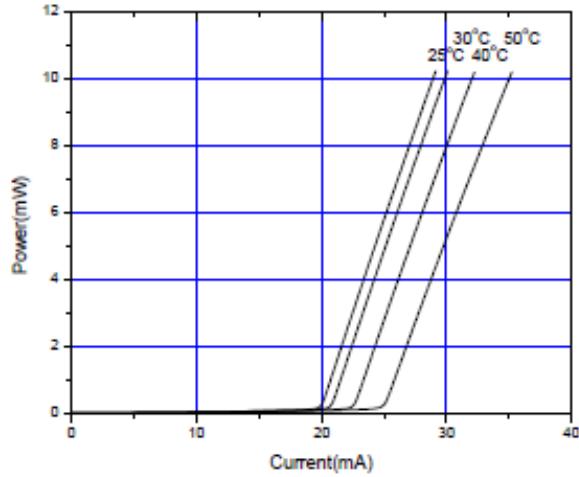

Mechanical Outline (unit: mm)

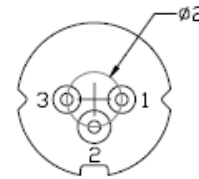
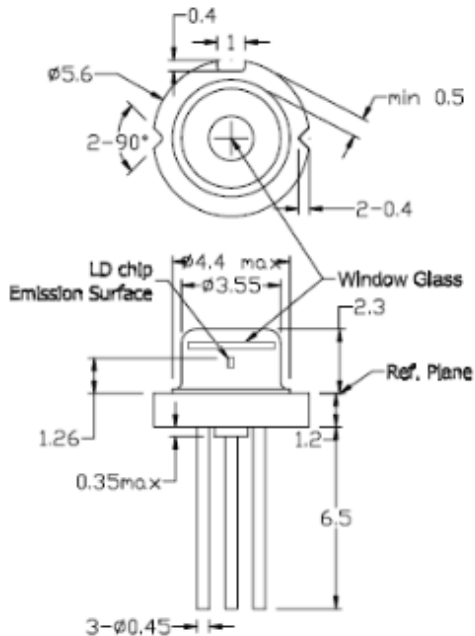

PIN CONFIGURATION

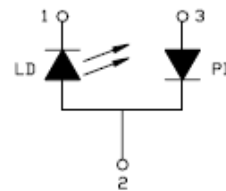

Additional Notes

- Do not operate the device above maximum ratings. Doing so may cause unexpected and permanent damage to the device.
- Take precautions to avoid electrostatic discharge and/or momentary power spikes. A change in the characteristics of the laser or premature failure may result.
- Proper heat sinking of the device assures stability and lifetime. Always ensure that maximum operating temperatures are not exceeded.
- Observing visible or invisible laser beams with human eye directly, or indirectly, can cause permanent damage. Use a camera to observe the laser.
- No laser device should be used in any application or situation where life or property is at risk in the event of device failure.
- Specifications are subject to change without notice. Ensure that you have the latest specification by contacting us prior to purchase or use of the product.