



## LD635D500F13

## High Power 635nm 500mW FP Laser Diode in TO3 Package

## Description

The Lasermate LD635D500F13 is a high power 635nm, 500mW laser diode in a TO3 package. The laser diode is suitable as a light source for many applications, including laser display, PDT, biochemistry, military, medical/life and health science, and illumination.

## Features

- 635nm Fabry-Perot cavity semiconductor laser diode
- Optical output power: 500mW CW
- High power
- No monitor photodiode
- Package: TO3

## Applications

- Laser display
- PDT
- Biochemistry
- Military
- Medical/Life and health science
- Illumination

Specifications ( $T_c = 20^\circ\text{C}$ )

## Optical Characteristics

PARAMETER	MIN.	TYP.	MAX.	UNIT
Lasing wavelength	625	635	645	nm
Output power	-	500	-	mW
Spectral width	-	1.0	2.0	nm
Emitting area width	-	150	-	um
Temperature coefficient	-	0.30	-	nm/ $^\circ\text{C}$
Fast axis divergence	-	34	38	deg
Slow axis divergence	-	7	10	deg

## Electrical Characteristics

PARAMETER	MIN.	TYP.	MAX.	UNIT
Slope efficiency	0.90	-	-	W/A
Threshold current	-	0.60	0.80	A
Operating current	-	1.15	1.35	A
Operating voltage	-	2.10	2.30	V

## Other Characteristics

PARAMETER	MIN.	TYP.	MAX.	UNIT
Package	TO3			-
Operating temperature	10		30	$^\circ\text{C}$
Storage temperature	-10		+60	$^\circ\text{C}$



Typical Characteristics

*P-I-V CURVE*

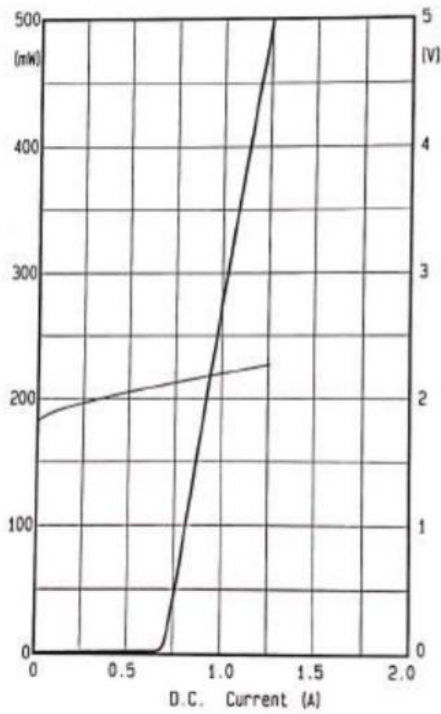

*SPECTRAL CURVE*

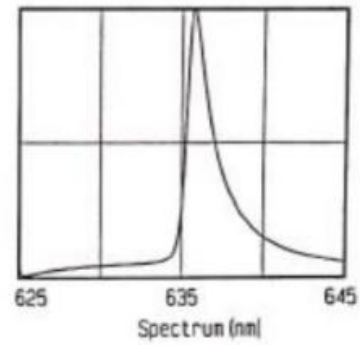

Mechanical Outline (unit: mm)

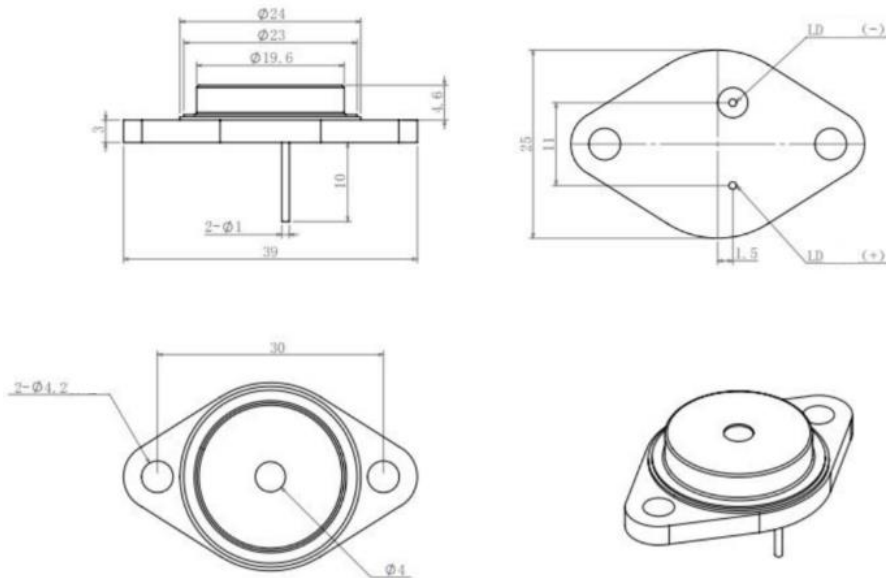

Additional Notes

- Data in the sheet are based on C-mount package heat sink testing.
- Do not operate the device above maximum ratings. Doing so may cause unexpected and permanent damage to the device.
- Take precautions to avoid electrostatic discharge and/or momentary power spikes. A change in the characteristics of the laser or premature failure may result.
- Proper heat sinking of the device assures stability and lifetime. Always ensure that maximum operating temperatures are not exceeded.
- Observing visible or invisible laser beams with human eye directly, or indirectly, can cause permanent damage. Use a camera to observe the laser.
- No laser device should be used in any application or situation where life or property is at risk in the event of device failure.
- Specifications are subject to change without notice. Ensure that you have the latest specification by contacting us prior to purchase or use of the product.