



10GBASE-ZR/ZW 1470nm~1610nm SMF 70km CWDM SFP+ Optical Transceiver with Duplex LC Connector

10GxxCWDM-USFPx



DESCRIPTION

The 10GxxCWDM-USFPx Enhanced Small Form Factor Pluggable SFP+ optical transceivers are RoHS compliant and designed for use in serial optical data communications application specified for a data rate of 10 Gb/s. The SFP+ transceiver module provides up to 70km transmission distance over single-mode fiber. There are eight center wavelengths available from 1470nm to 1610nm. They are compliant with SFF 8472 diagnostic monitoring interface, and EN60825-1, and supports CPRI line bit option 7:9830.4 Mbit/s.

FEATURES

- Compliant with SFF8472 diagnostic monitoring interface
- Duplex LC connector
- Hot pluggable SFP+ package
- Class 1 laser product compliant with EN 60825-1
- Support CPRI line bit rate option 7: 9830.4 Mbit/s
- 1550nm EML laser and APD receiver
- Single power supply 3.3V
- Up to 70km transmission on SMF

APPLICATIONS

- CWDM Network

PRODUCT OVERVIEW

PART NUMBER	OPERATING TEMPERATURE
10GxxCWDM-USFPC	0°C to 70°C
10GxxCWDM-USFPI	-40°C to 85°C

Where **xx** value is as follows: **xx = 47** for 1471nm, **xx = 49** for 1491nm, **xx = 51** for 1511nm, **xx = 53** for 1531nm, **xx = 55** for 1551nm, **xx = 57** for 1571nm, **xx = 59** for 1591nm, **xx = 61** for 1611nm

DIAGNOSTICS

PARAMETER	RANGE	ACCURACY	UNIT	CALIBRATION
Internal Transceiver Temperature	-40 to 85	±3	°C	Internal
Internal Transceiver Voltage	3.14 to 3.46	±0.1	V	
Bias Current	0 to 120	±10%	mA	
TX Power	0 to +4	±3	dB	
RX Average Power	-23 to -10	±3	dB	

ABSOLUTE MAXIMUM RATINGS

PARAMETER	SYMBOL	MIN	MAX	UNIT
Storage Temperature	T _s	-40	85	°C
Supply Voltage	V _{CC}	0	3.6	V
Input Voltage	V _{IN}	0	V _{CC}	V
Operating Relative Humidity	RH	0	85	%

RECOMMENDED OPERATING CONDITIONS

PARAMETER	SYMBOL	MIN	MAX	UNIT	NOTES
Case Operating Temperature	T _c	0	70	°C	10GxxCWDM-USFPC
		-40	85		10GxxCWDM-USFPI
Supply Voltage	V _{CC}	3.14	3.46	V	
Supply Current	I _{TX} + I _{RX}		545	mA	10GxxCWDM-USFPC
			645		10GxxCWDM-USFPI
Power Consumption @3.3V	P	-	1.8	W	10GxxCWDM-USFPC
			2.1		10GxxCWDM-USFPI

TRANSMITTER ELECTRO-OPTICAL CHARACTERISTICS (V_{CC} = 3.14V to 3.46V, T_c = 0°C to 70°C, -40°C to 85°C)

PARAMETER	SYMBOL	MIN	TYP.	MAX	UNIT	NOTES
Data Rate	B		10.3125		Gbps	
Output Optical Power	P _{out}	0	-	+4.0	dBm	
Extinction Ratio	ER	8.2			dB	
Center Wavelength	λ _c	-6.5	x	+6.5	nm	x = specified center wavelength
Spectral Width (RMS)	Δλ	-	-	1	nm	
Side Mode Suppression Ratio	SSR _{min}	30			dB	
Transmitter and Dispersion Penalty	TDP			3	dB	
Relative Intensity Noise	RIN	-	-	-128	dB/Hz	
Optical Return Loss	ORL	21	-	-	dB	
Output Eye		Compliant with IEEE802.3ae				
Differential Input Impedance	Z _d		100		Ω	
Differential Input Voltage Swing	V _{DIFF}	300		1000	mVpp	
Transmit Fault Output-Low	TX_FAULT _L	0.0	-	0.5	V	
Transmit Fault Output-High	TX_FAULT _H	2.4	-	V _{CC}	V	
TX_DISABLE Assert Time	t _{off}	-	-	100	μs	
TX_DISABLE Negate Time	t _{on}	-	-	2	ms	
TX_FAULT from fault to assertion	t _{fault}	-	-	50	ms	
TX_DISABLE Time to start reset	t _{reset}	10	-	-	μs	

RECEIVER ELECTRO-OPTICAL CHARACTERISTICS ($V_{CC} = 3.14V$ to $3.46V$, $T_C = 0^{\circ}C$ to $70^{\circ}C$, $-40^{\circ}C$ to $85^{\circ}C$)

PARAMETER	SYMBOL	MIN	TYP.	MAX	UNIT	NOTES
Data Rate	B		10.3125		Gbps	
Optical Input Power – maximum	P_{IN}	-7	-	-	dBm	BER< 10^{-12}
Receiver Sensitivity@10.3125 Gbps	P_{IN}	-	-	-23	dBm	BER< 10^{-12}
Receiver Sensitivity with 70km fiber @10.3125G	P_{IN_fiber}	-	-	-20	dBm	BER< 10^{-12}
Operating Center Wavelength	λ_C	1460	-	1620	nm	
Loss of Signal-Asserted	P_A	-38	-	-	dBm	
Loss of Signal-Deasserted	P_D	-	-	-25	dBm	
Differential Output Impedance	Z_d	-	100	-	Ω	
Differential Output Voltage	V_{DIFF}	300	-	800	mVpp	
Receiver Loss of Signal Output Voltage-Low	RX_LOSL	0	-	0.5	V	
Receiver Loss of Signal Output-High	RX_LOSH	2.4	-	V_{CC}	V	
Receiver Loss of Signal Assert Time (off to on)	t_{A,RX_LOS}	-	-	100	μs	
Receiver Loss of Signal Assert Time (on to off)	t_{D,RX_LOS}	-	-	100	μs	

TIMING PARAMETERS

PARAMETER	SYMBOL	MIN	TYP.	MAX	UNIT	NOTES
Time to Initialize	t_{start_up}			10	s	

DIMENSIONS (unit: mm)

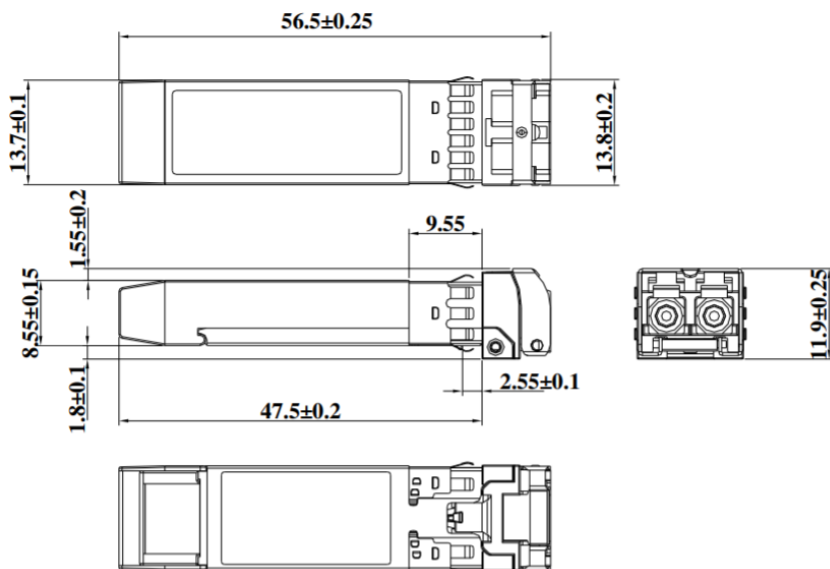

SFP HOST BOARD MECHANICAL LAYOUT (unit: mm)

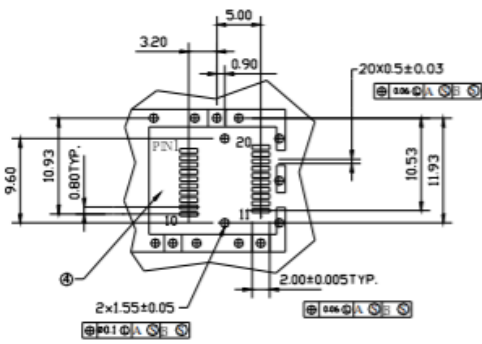
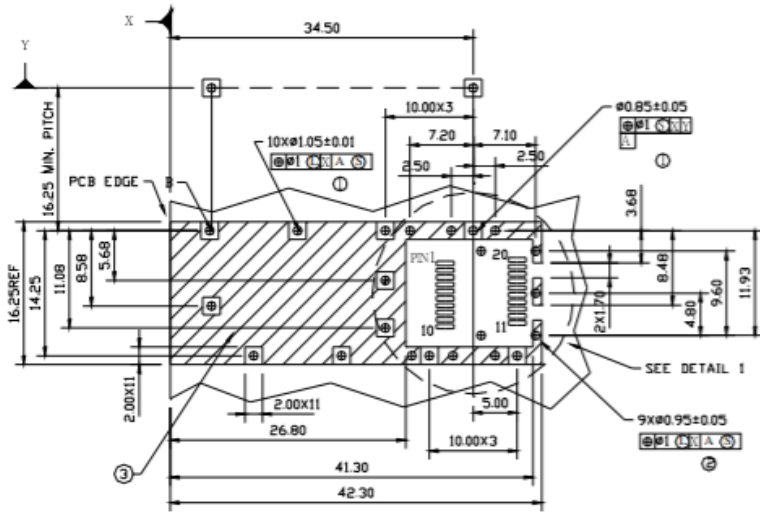

LEGEND

- 1. PADS AND VIAS ARE CHASSIS GROUND
- 2. THROUGH HOLES, PLATING OPTIONAL
- 3. HATCHED AREA DENOTES COMPONENT AND TRACE KEEPOUT (EXCEPT CHASSIS GROUND)
- 4. AREA DENOTES COMPONENT KEEPOUT (TRACES ALLOWED)

DIMENSIONS ARE IN MILLIMETERS

ASSEMBLY DRAWING

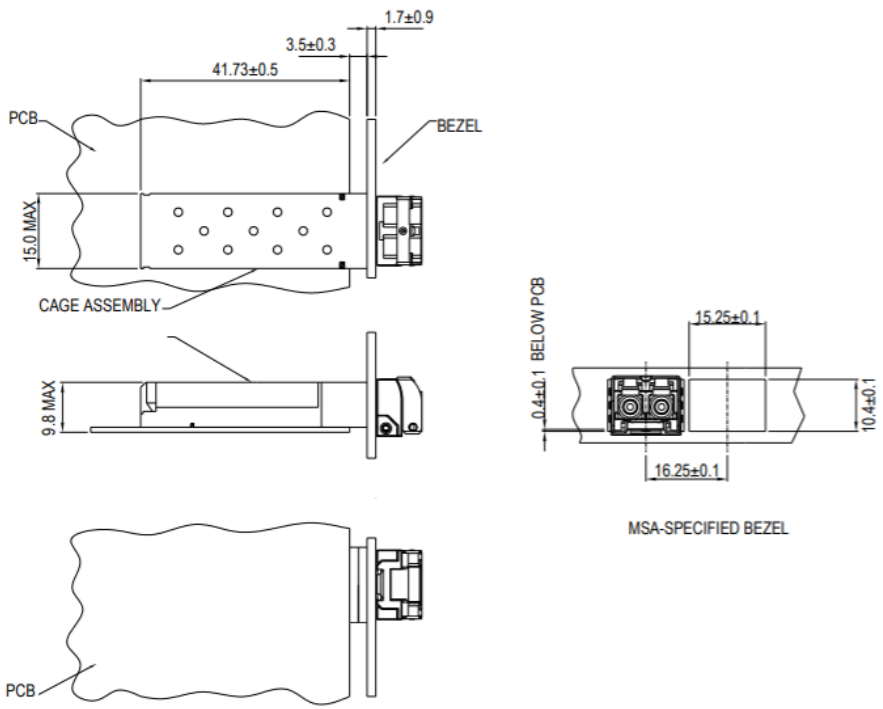

DIMENSIONS ARE IN MILLIMETERS

RECOMMENDED INTERFACE CIRCUIT

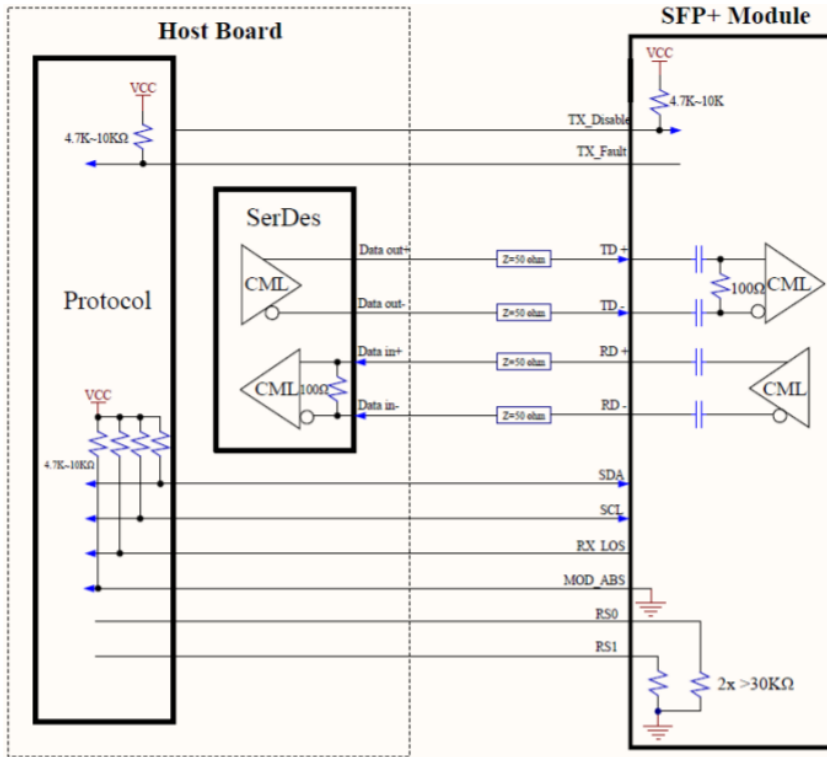

PIN ASSIGNMENT

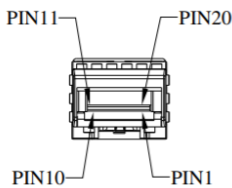

PIN	SIGNAL NAME	DESCRIPTION	PIN	SIGNAL NAME	DESCRIPTION
1	T _{GND}	Transmit Ground	11	R _{GND}	Receiver Ground
2	TX_FAULT	Transmit Fault	12	RX-	Receive Data out Bar, ac coupled
3	TX_DISABLE	Transmit Disable	13	RX+	Receive Data out, ac coupled
4	MOD_DEF (2)	SDA Serial Data Signal	14	R _{GND}	Receiver Ground
5	MOD_DEF (1)	SCL Serial Clock Signal	15	V _{CCR}	Receiver Power Supply
6	MOD_DEF (0)	TTL Low	16	V _{CCT}	Transmitter Power Supply
7	RS0	RX Rate Select, no function implemented	17	T _{GND}	Transmitter Ground
8	RX_LOS	Receiver Loss of Signal, TTL High, open collector	18	TX+	Transmit Data in, ac coupled
9	RS1	TX Rate Select, no function implemented	19	TX-	Transmit Data in Bar, ac coupled
10	R _{GND}	Receiver Ground	20	T _{GND}	Transmitter Ground

ADDITIONAL NOTES

- Avoid eye or skin exposure to laser radiations.
- The device is sensitive to electro-static discharge (ESD). The device should be handled with ESD proof tools. To assemble the device on PCB, proper grounding is required to prevent ESD.
- Specifications are subject to change without notice.



Lasermate Group, Inc.
19608 Camino De Rosa
Walnut, CA 91789 USA
Tel: (909)718-0999
Fax: (909)718-0998
sales@lasermate.com
www.lasermate.com