

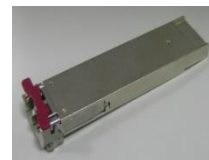

10GFC 10GBASE-EW/ER 1470nm-1610nm SMF 40km CWDM XFP (10Gbps SFP) Optical Transceiver with Duplex LC Connector

CS15xxD-X-4L-Tx-L



DESCRIPTION

The CS15xxD-X-4L-Tx-L Small Form Factor 10b/s (XFP) optical transceivers are compliant with XFP Multi-Source Agreement (MSA). It provides up to 40km transmission distance over single-mode fiber. There are eight center wavelengths available from 1470nm to 1610nm with 20nm channel spacing. The optical transceiver is RoHS compliant.

FEATURES

- Compliant with IEEE802.3ae 10GBASE-EW/ER Ethernet standard
- Compliant with SONET OC-192 IR-2/SONET OC-192 IR-3
- Compliant with SDH STM S-64.2b/SDH STM S-64.3b
- Compliant with SONET OC-192/SDH STM-64 with ITU-T G.709
- Compliant with 10G Fiber Channel
- Compliant with XFP MSA INF-8077i
- Differential CML inputs and outputs
- Power consumption <3.5W
- TTL signal detect indicator
- Class 1 laser product compliant with EN 60825-1
- Transmission distance up to 40km
- Input/Output: AC/AC

APPLICATIONS

- CWDM Network
- 10GFC 10GBASE-ZR/ZW
- SONET SDH ITU-T G.709

PRODUCT OVERVIEW

PART NUMBER	INPUT/OUTPUT	VOLTAGE	OPERATING TEMPERATURE
CS15xxD-X-4L-TC-L	AC/AC	3.3V/5.0V	-5 to 70°C
CS15xxD-X-4L-TI-L	AC/AC	3.3V/5.0V	-45 to 85°C

Where xx value is as follows: xx = 47 for 1470nm, xx = 49 for 1490nm, xx = 51 for 1510nm, xx = 53 for 1530nm, xx = 55 for 1550nm, xx = 57 for 1570nm, xx = 59 for 1590nm, xx = 61 for 1610nm

ABSOLUTE MAXIMUM RATINGS

PARAMETER	SYMBOL	MIN	MAX	UNIT
Storage Temperature	T _s	-40	85	°C
Supply Voltage	V _{CC3}	-0.5	4.0	V
	V _{CC5}	-0.5	6.0	V

RECOMMENDED OPERATING CONDITIONS

PARAMETER	SYMBOL	MIN	MAX	UNIT	NOTES
Case Operating Temperature	T _c	-5	70	°C	CS15xxD-X-4L-TC-L
		-45	85		CS15xxD-X-4L-TI-L
Supply Voltage	V _{CC3}	3.1	3.5	V	
Supply Current	I _{CC3}	-	600	mA	
Supply Voltage	V _{CC5}	4.75	5.25	V	
Supply Current	I _{CC5}	-	300	mA	CS15xxD-X-4L-TC-L
			400		CS15xxD-X-4L-TI-L

DIAGNOSTICS

DATA ADDRESS	PARAMETER	RANGE	ACCURACY
96-97	Temperature	-40 to 85°C	±3°C
100-101	Bias Current	0 to 120mA	±10%
102-103	TX Power	-2 to +3dBm	±2dB
104-105	RX Power	-17 to 0dBm	±2dB
106-107	V _{CC3} Voltage	3.0-3.6Volts	±3%
108-109	V _{CC5} Voltage	4.5-5.5Volts	±3%

TRANSMITTER ELECTRO-OPTICAL CHARACTERISTICS

PARAMETER	SYMBOL	MIN	TYP.	MAX	UNIT	NOTES
Operating Data Rate	D	9.95		11.3	Gbps	
Input Reference Clock Rate		Not required				
Output Optical Power	P _{out}	-1	-	+2	dBm	
Extinction Ratio	ER	9.2	-	-	dB	
Transmitter Dispersion Penalty (@800ps/nm)	TDP			3	dB	
Center Wavelength (1470nm)	λ _c	1464.5	-	1477.5	nm	
Center Wavelength (1490nm)		1484.5	-	1497.5		
Center Wavelength (1510nm)		1504.5	-	1517.5		
Center Wavelength (1530nm)		1524.5	-	1537.5		
Center Wavelength (1550nm)		1544.5	-	1557.5		
Center Wavelength (1570nm)		1564.5	-	1577.5		
Center Wavelength (1590nm)		1584.5	-	1597.5		
Center Wavelength (1610nm)		1604.5	-	1617.5		
Side Mode Suppression Ratio	SSR _{min}	30			dB	
Relative Intensity Noise	RIN	-	-	-130	dB/Hz	
Output Eye	Compliant with IEEE802.3ae					
Differential Input Voltage	V _{DIFF}	0.12	-	1.0	V	
Transmit Fault Output-Low	TX_FAULT _L	0.0	-	0.5	V	
Transmit Fault Output-High	TX_FAULT _H	2.4	-	V _{CC}	V	
TX_DISABLE Assert Time	t _{off}	-	-	10	us	
TX_DISABLE Negate Time	t _{on}	-	-	2	ms	
Time to initialize	t _{init}	-	-	300	ms	
Interrupt assert delay	Interrupt _{on}	-	-	200	ms	
Interrupt negate delay	Interrupt _{off}	-	-	500	us	
P_Down/RST assert delay	P_Down/RST _{on}			100	us	
Mod_NR assert delay	Mod_nr _{on}			1	ms	
Mod_NR negate delay	Mod_nr _{off}			1	ms	
P-Down reset time		10			us	
RX_LOS assert delay	t _{loss_on}			100	us	
RX_LOS negate delay	t _{loss_off}			100	us	

RECEIVER ELECTRO-OPTICAL CHARACTERISTICS

PARAMETER	SYMBOL	MIN	TYP.	MAX	UNIT	NOTES
Optical Input Power-maximum	P_{IN}	-1				BER<10 ⁻¹²
Receiver Sensitivity	P_{IN}	-	-	-16	dBm	BER<10 ⁻¹²
Receiver Sensitivity (OMA)	P_{IN}	-	-	-14.1	dBm	BER<10 ⁻¹²
Operating Center Wavelength	λ_C	1270	-	1620	nm	
Receiver Reflectance	R _{RX}	27	-	-	dB	
Loss of Signal-Asserted	P _A	-30	-	-	dBm	
Loss of Signal-Deasserted	P _D	-	-	-22	dBm	
Differential Output Voltage	V _{DIFF}	0.6		0.8	V	
TTL Input High Voltage		2		V _{CC}	V	
TTL Input Low Voltage		0		0.8	V	
TTL Output High Voltage		2.4	-	V _{CC}	V	
TTL Output Low Voltage		0	-	0.4	V	
Receiver Loss of Signal Assert Time (off to on)	t _{A,RX_LOS}	-	-	100	us	
Receiver Loss of Signal Assert Time (on to off)	t _{D,RX_LOS}	-	-	100	us	

BLOCK DIAGRAM OF TRANSCEIVER

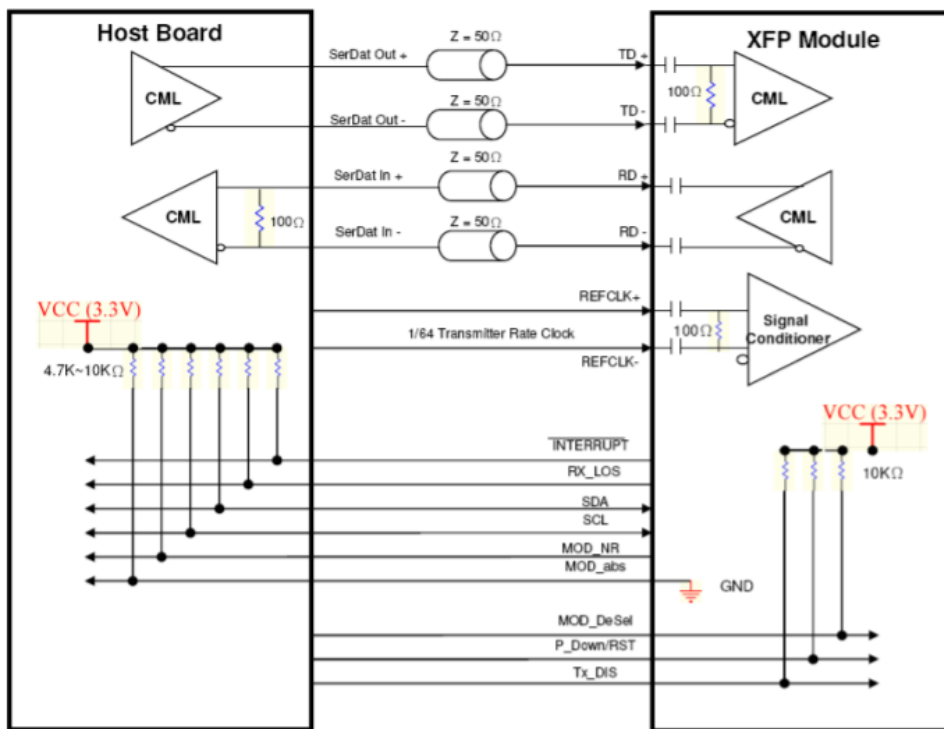

MOD_NR

The Mod_NR is an output pin that when High, indicates that the module has detected a condition that renders transmitter and or receiver data invalid, shall consist of logical OR of the following signals:

- Transmit Signal Conditioner Loss of Lock
- Transmitter Laser Fault
- Receiver Signal Conditioner Loss of Lock

MOD_DESEL

The Mod_DeSel is an input pin. When held Low by the host, the module responds to 2-wire serial communication commands. The Mod_DeSel allows the use of multiple XFP modules on a single 2-wire interface bus. When the Mod_DeSel pin is “High”, the module shall not respond to or acknowledge any 2-wire interface communication from the host.

Interrupt

Interrupt is an output pin. When “Low”, indicates possible module operational fault or a status critical to the host system.

TX_DIS

TX_DIS is an input pin. When TX_DIS is asserted High, the XFP module transmitter output must be turned off.

MOD_ABS

Mod_ABS is pulled up to Host_Vcc on the host board and grounded in the XFP module. Mod_ABS is then asserted “High” when the XFP module is physically absent from a host slot.

RX_LOS

The RX_LOS when High indicates insufficient optical power for reliable signal reception.

P_DOWN/RST

This is a multifunction pin for module Power Down and Reset. The P_Down/RST pin must be pulled up to VCC3 in the XFP module.

POWER DOWN FUNCTION

The P_Down pin, when held High by the host, places the module in the standby (Low Power) mode with a maximum power dissipation of 1.5W. This protects hosts which are not capable of cooling higher power modules which may be accidentally inserted.

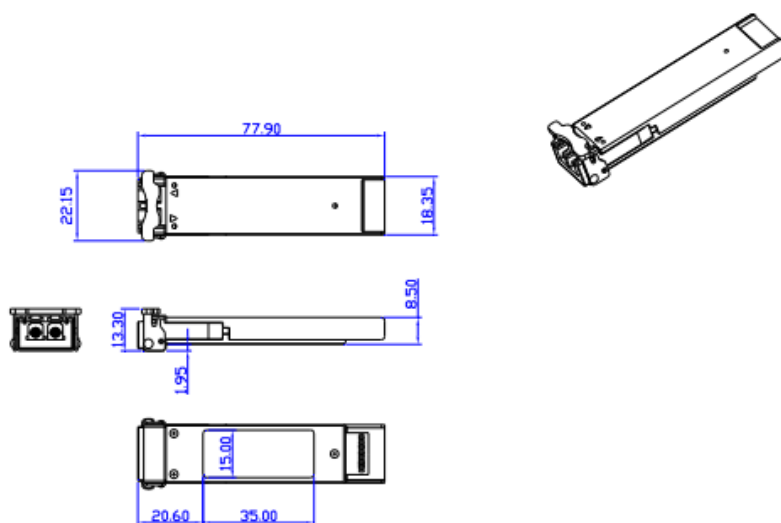
DIMENSIONS

DIMENSIONS ARE IN MILLIMETERS

ALL DIMENSIONS ARE $\pm 0.2\text{mm}$ UNLESS OTHERWISE SPECIFIED

PIN ASSIGNMENT

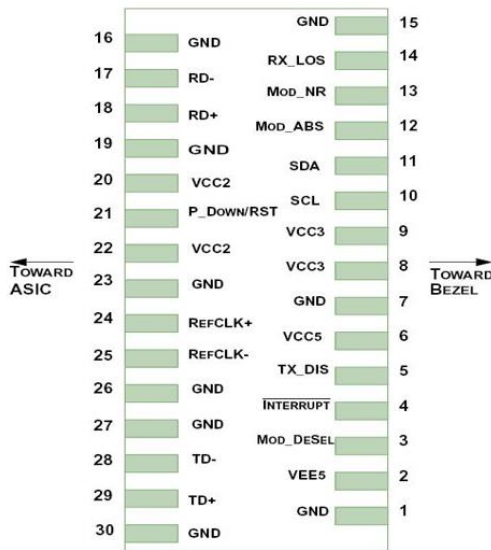

Pin	Logic	Symbol	Name/Description	Note
1		GND	Module Ground	1
2		VEE5	Optional -5.2V Power Supply	
3	LVTTL-I	Mod_DeSel	Module De-select; When held low allows module to respond to 2-wire serial interface	
4	LVTTL-O	Interrupt	Interrupt; Indicates presence of an important condition which can be read over the 2-wire serial interface	2
5	LVTTL-I	TX_DIS	Transmitter Disable; Turns off transmitter laser output	
6		VCC5	+5V Power Supply	
7		GND	Module Ground	1
8		VCC3	+3.3V Power Supply	
9		VCC3	+3.3V Power Supply	
10	LVTTL-I/O	SCL	2-Wire Serial Interface Clock	2
11	LVTTL-I/O	SDA	2-Wire Serial Interface Data Line	2
12	LVTTL-O	Mod_Abs	Indicates Module is not present. Grounded in the Module	2
13	LVTTL-O	Mod_Nr	Module Not Ready; Indicating Module Operational Fault	2
14	LVTTL-O	RX_Los	Receiver Loss Of Signal Indicator	2
15		GND	Module Ground	1
16		GND	Module Ground	1
17	CML-O	RD-	Receiver Inverted Data Output	
18	CML-O	RD+	Receiver Non-Inverted Data Output	
19		GND	Module Ground	1
20		VCC2	+1.8V Power Supply	3
21	LVTTL-I	P_Down/RST	Power down; When high, requires the module to limit power consumption to 1.5W or below. 2-Wire serial interface must be functional in the low power mode. Reset; The falling edge initiates a complete reset of the module including the 2-wire serial interface, equivalent to a power cycle.	
22		VCC2	+1.8V Power Supply	3
23		GND	Module Ground	1
24	PECL-I	RefClk+	Reference Clock Non-Inverted Input, AC coupled on the host board	
25	PECL-I	RefClk-	Reference Clock Inverted Input, AC coupled on the host board	
26		GND	Module Ground	1
27		GND	Module Ground	1
28	CML-I	TD-	Transmitter Inverted Data Input	
29	CML-I	TD+	Transmitter Non-Inverted Data Input	
30		GND	Module Ground	1

1. Module ground pins Gnd are isolated from the module case and chassis ground within the module.
2. Shall be pulled up with 4.7K-10Kohms to a voltage between 3.15V and 3.45V on the host board.
3. The 1.8 V power supply can be optionally programmed to voltages lower than 1.8 V in modules supporting the variable power supply.

EYE SAFETY MARK

The single mode transceiver is a class 1 laser product. It complies with EN 60825-1 and FDA 21 CFR 1040.10 and 1040.11. In order to meet laser safety requirements, the transceiver shall be operated within the Absolute Maximum Ratings.

Required Mark

Class 1 Laser Product
Complies with
21 CFR 1040.10 and 1040.11

[Caution] All adjustments have been done at the factory before the shipment of the devices. No maintenance and user serviceable part is required. Tampering with and modifying the performance of the device will result in voided product warranty.

ADDITIONAL NOTES

- Avoid eye or skin exposure to laser radiations.
- The device is sensitive to electro-static discharge (ESD). The device should be handled with ESD proof tools. To assemble the device on PCB, proper grounding is required to prevent ESD.
- Specifications are subject to change without notice.



Lasermate Group, Inc.
19608 Camino De Rosa
Walnut, CA 91789 USA
Tel: (909)718-0999
Fax: (909)718-0998
sales@lasermate.com
www.lasermate.com