

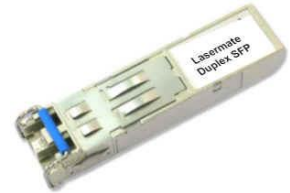

2.5Gbps 1550nm SMF 80km SFP Optical Transceiver with Duplex LC Connector

CS15D-48F-3E-TI-LD



DESCRIPTION

The CS15D-48F-3E-TI-LD duplex SFP (Small Form Pluggable) optical transceivers are high performance, cost effective optical transceiver modules for serial optical data communications application specified for a data rate of 2.5Gb/s. The SFP transceiver module provides 80km transmission distance over single-mode fiber at nominal wavelength of 1550nm. The optical transceiver is RoHS compliant.

FEATURES

- Compliant with SFF8472 diagnostic monitoring interface
- Industry standard small form pluggable (SFP) package
- Multi-Rate
- With APD
- Hot pluggable
- Single power supply 3.3V
- Duplex LC connector
- TTL LOS indicator
- Class 1 laser product compliant with EN 60825-1
- Input/Output: AC/AC
- Temperature: -40°C to 85°C
- Up to 80km over single mode fiber

APPLICATIONS

- Extended L16.2

DIAGNOSTICS

PARAMETER	RANGE	ACCURACY	UNIT	CALIBRATION
Temperature	-40 to 95	±3	°C	External
Voltage	3.1 to 3.5	±0.1	V	
Bias Current	0 to 90	±10%	mA	
TX Power	0 to +5	±3 dB	dBm	
RX Power	-30 to -9	±3 dB	dBm	

ABSOLUTE MAXIMUM RATINGS

PARAMETER	SYMBOL	MIN	MAX	UNIT
Storage Temperature	T_S	-40	85	°C
Supply Voltage	V_{CC}	-0.5	4.0	V
Input Voltage	V_{IN}	-0.5	V_{CC}	V

RECOMMENDED OPERATING CONDITIONS

PARAMETER	SYMBOL	MIN	MAX	UNIT
Case Operating Temperature	T_C	-40	85	°C
Supply Voltage	V_{CC}	3.1	3.5	V
Supply Current	$I_{TX} + I_{RX}$	-	300	mA

TRANSMITTER ELECTRO-OPTICAL CHARACTERISTICS ($V_{CC} = 3.1V$ to $3.5V$, $T_C = -40^{\circ}C$ to $85^{\circ}C$)

PARAMETER	SYMBOL	MIN	TYP.	MAX	UNIT	NOTES
Output Optical Power 9/125um fiber	P_{out}	+0	-	+5	dBm	Average
Extinction Ratio	ER	8.2	-	-	dB	
Center Wavelength	λ_c	1520	1550	1580	nm	
Spectral Width (-20dB)	$\Delta\lambda$	-	-	0.7	nm	
Side Mode Suppression Ratio	SMSR	30	-	-	dB	
Output Eye	Compliant with Telcordia GR-253-CORE Issue 3 and ITU-T recommendation G-957					
Max. P_{out} TX-DISABLE Asserted	P_{OFF}	-	-	-45	dBm	
Differential Input Voltage	V_{DIFF}	0.4	-	2.0	V	
Optical Path Penalty				2	dB	
Maximum Dispersion				1680	ps/nm	

RECEIVER ELECTRO-OPTICAL CHARACTERISTICS (V_{CC} = 3.1V to 3.5V, T_C = -40°C to 85°C)

PARAMETER	SYMBOL	MIN	TYP.	MAX	UNIT	NOTES
Optical Input Power-Maximum	P _{IN}	-8	-	-	dBm	BER<10 ⁻¹⁰
RX Sensitivity @2.67 Gb/s	P _{IN}	-	-	-30	dBm	PRBS23, BER<10 ⁻¹⁰
RX Sensitivity @OC-48	P _{IN}	-	-	-30	dBm	PRBS23, BER<10 ⁻¹⁰
RX Sensitivity @2xFC	P _{IN}	-	-	-30	dBm	PRBS7, BER<10 ⁻¹²
RX Sensitivity @GbE	P _{IN}	-	-	-30	dBm	PRBS7, BER<10 ⁻¹²
RX Sensitivity @OC-12	P _{IN}	-	-	-30	dBm	PRBS23, BER<10 ⁻¹⁰
RX Sensitivity @OC-3	P _{IN}	-	-	-30	dBm	PRBS23, BER<10 ⁻¹⁰
RX Sensitivity @Fast Ethernet	P _{IN}	-	-	-30	dBm	PRBS7, BER<10 ⁻¹⁰
Operating Center Wavelength	λ _C	1500	-	1600	nm	
Optical Return Loss	ORL	-27	-	-	dB	
Signal Detect-Asserted	P _A	-	-	-30	dBm	
Signal Detect-Deasserted	P _D	-45	-	-	dBm	
Differential Output Voltage	V _{DIFF}	0.5	-	1.2	V	
Receiver Loss of Signal Output Voltage-Low	RX_LOSL	0	-	0.5	V	
Receiver Loss of Signal Output Voltage-High	RX_LOSH	2.4	-	V _{CC}	V	

BLOCK DIAGRAM OF TRANSCEIVER

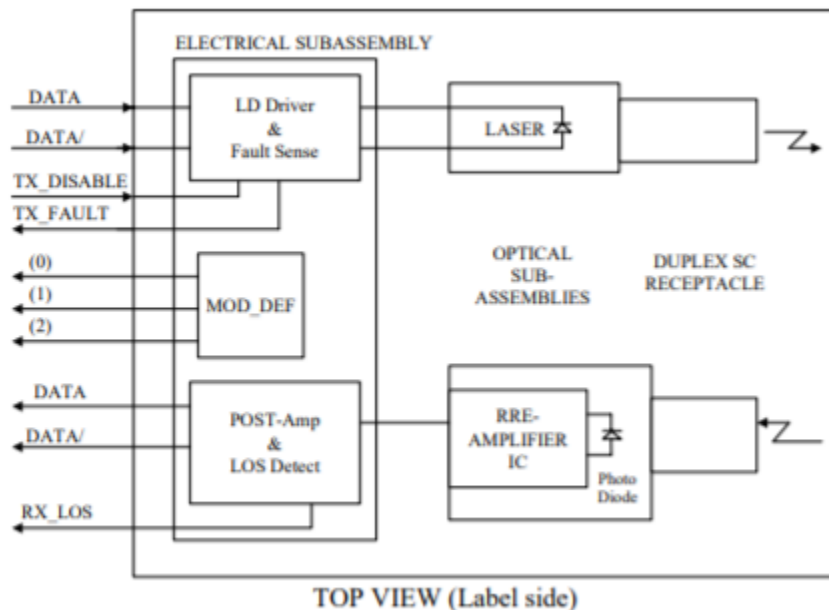

Transmitter Section - The transmitter section consists of a 1550 nm InGaAsP laser in an eye safe optical subassembly (OSA) which mates to the fiber cable. The laser OSA is driven by a LD driver IC which converts differential input LVPECL logic signals into an analog laser driving current.

TX_DISABLE - The TX_DISABLE signal is high (TTL logic “1”) to turn off the laser output. The laser will turn on when TX_DISABLE is low (TTL logic “0”).

Receiver Section - The receiver utilizes an APD photodiode mounted together with a trans-impedance preamplifier IC in an OSA. This OSA is connected to a circuit providing post-amplification quantization, and optical signal detection.

Receive Loss (RX_LOS) - The RX_LOS is high (logic “1”) when there is no incoming light from the companion transceiver. This signal is normally used by the system for the diagnostic purpose. The signal is operated in TTL level.

DIMENSIONS

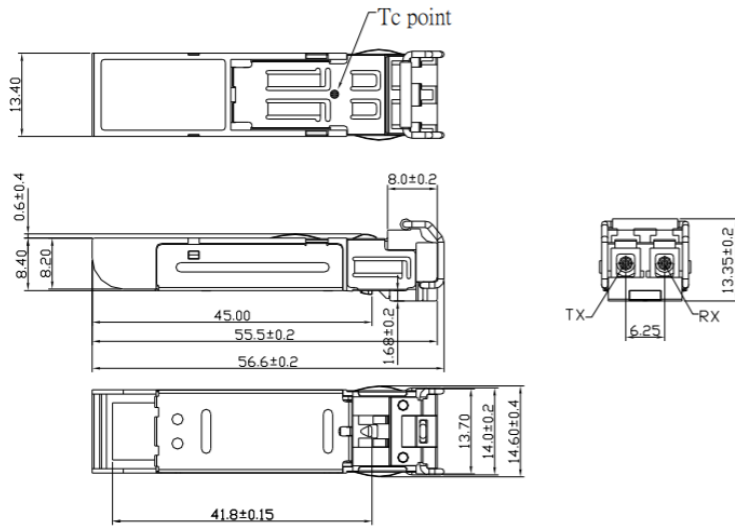

DIMENSIONS ARE IN MILLIMETERS

ALL DIMENSIONS ARE ± 0.1mm UNLESS OTHERWISE SPECIFIED

SFP HOST BOARD MECHANICAL LAYOUT

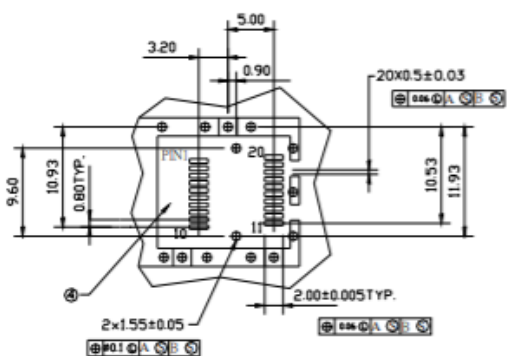
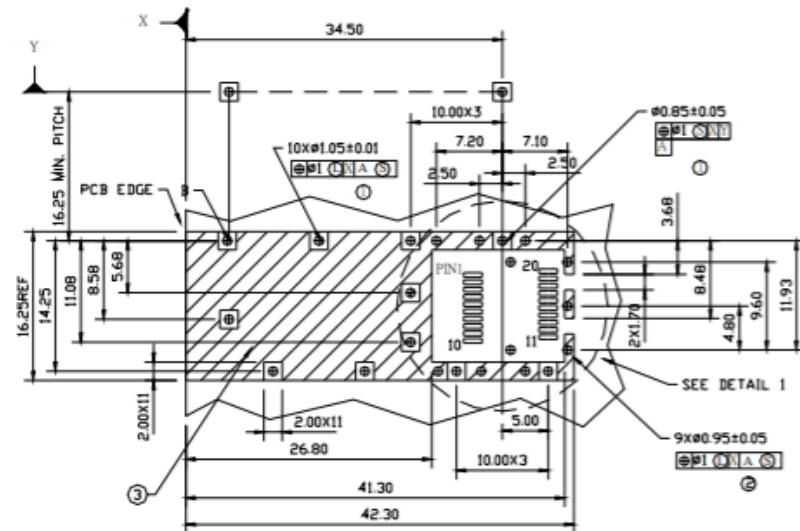

LEGEND

1. PADS AND VIAS ARE CHASSIS GROUND
2. THROUGH HOLES, PLATING OPTIONAL
3. HATCHED AREA DENOTES COMPONENT AND TRACE KEEPOUT (EXCEPT CHASSIS GROUND)
4. AREA DENOTES COMPONENT KEEPOUT (TRACES ALLOWED)

DIMENSIONS ARE IN MILLIMETERS

ASSEMBLY DRAWING (unit: mm)

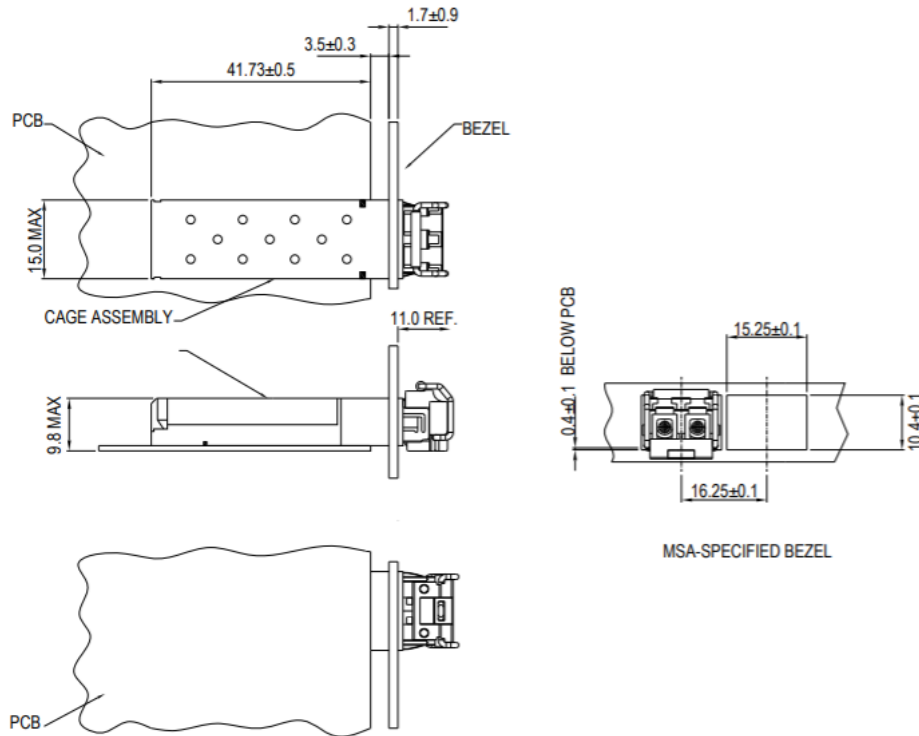

PIN ASSIGNMENT

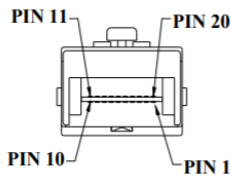

PIN	SIGNAL NAME	DESCRIPTION	PIN	SIGNAL NAME	DESCRIPTION
1	T _{GND}	Transmit Ground	11	R _{GND}	Receiver Ground
2	TX_FAULT	Transmit Fault	12	RX-	Receive Data Bar, Differential, ac coupled
3	TX_DISABLE	Transmit Disable	13	RX+	Receive Data, Differential, ac coupled
4	MOD_DEF (2)	SDA Serial Data Signal	14	R _{GND}	Receiver Ground
5	MOD_DEF (1)	SCL Serial Clock Signal	15	V _{CCR}	Receiver Power Supply
6	MOD_DEF (0)	TTL Low	16	V _{CCT}	Transmitter Power Supply
7	RATE SELECT	Open Circuit	17	T _{GND}	Transmitter Ground
8	RX_LOS	Receiver Loss of Signal, TTL High, open collector	18	TX+	Transmit Data, Differential, ac coupled
9	R _{GND}	Receiver Ground	19	TX-	Transmit Data Bar, Differential, ac coupled
10	R _{GND}	Receiver Ground	20	T _{GND}	Transmitter Ground

ADDITIONAL NOTES

- Avoid eye or skin exposure to laser radiations.
- The device is sensitive to electro-static discharge (ESD). The device should be handled with ESD proof tools. To assemble the device on PCB, proper grounding is required to prevent ESD.
- Specifications are subject to change without notice.



Lasermate Group, Inc.
19608 Camino De Rosa
Walnut, CA 91789 USA
Tel: (909)718-0999
Fax: (909)718-0998
sales@lasermate.com
www.lasermate.com