



1.25Gbps 1270nm~1450nm SMF 32dB CWDM SFP Optical Transceiver with Duplex LC Connector

CS13xxD-24F-3U3-TC-LD



DESCRIPTION

The CS13xxD-24F-3U3-TC-LD duplex SFP (Small Form Pluggable) optical transceivers are high performance, cost effective optical transceiver modules support data rates up to 1.25Gb/s. They provide 32dB power budget over single mode fiber. There are ten center wavelengths available from 1270nm to 1450nm with 20nm channel spacing.

FEATURES

- Compliant with IEEE802.3z Gigabit Ethernet Standard
- Compliant with Fiber Channel 100-SM-LC-L standard
- Compliant with SFF8472 diagnostic monitoring interface
- Industry standard small form pluggable (SFP) package
- Duplex LC connector
- Differential PECL inputs and outputs
- Hot pluggable
- Class 1 laser product compliant with EN 60825-1
- Single power supply 3.3V
- TTL signal detect indicator
- Input/Output: AC/AC
- Operating case temperature range: 0°C to 70°C
- 32dB power budget

APPLICATIONS

- CWDM Network

PRODUCT OVERVIEW

PART NUMBER	WAVELENGTH	OPERATING TEMPERATURE
CS1327D-24F-3U3-TC-LD	1270nm	0°C to 70°C
CS1329D-24F-3U3-TC-LD	1290nm	0°C to 70°C
CS1331D-24F-3U3-TC-LD	1310nm	0°C to 70°C
CS1333D-24F-3U3-TC-LD	1330nm	0°C to 70°C
CS1335D-24F-3U3-TC-LD	1350nm	0°C to 70°C
CS1337D-24F-3U3-TC-LD	1370nm	0°C to 70°C
CS1339D-24F-3U3-TC-LD	1390nm	0°C to 70°C
CS1341D-24F-3U3-TC-LD	1410nm	0°C to 70°C
CS1343D-24F-3U3-TC-LD	1430nm	0°C to 70°C
CS1345D-24F-3U3-TC-LD	1450nm	0°C to 70°C

DIAGNOSTICS

PARAMETER	RANGE	ACCURACY	UNIT	CALIBRATION
Temperature	-40 to 95	±3	°C	External
Voltage	0 to VCC	±0.1	V	
Bias Current	0 to 120	±5	mA	
TX Power	-3 to +6	±3 dB	dBm	
RX Power	-30 to -10	±3 dB	dBm	

ABSOLUTE MAXIMUM RATINGS

PARAMETER	SYMBOL	MIN	MAX	UNIT
Storage Temperature	T _S	-40	85	°C
Supply Voltage	V _{CC}	-0.5	4.0	V
Input Voltage	V _{IN}	-0.5	V _{CC}	V
Output Current	I _O	-	50	mA
Operating Current	I _{OP}	-	400	mA

RECOMMENDED OPERATING CONDITIONS

PARAMETER	SYMBOL	MIN	MAX	UNIT
Case Operating Temperature	T _C	0	70	°C
Supply Voltage	V _{CC}	3.1	3.5	V
Supply Current	I _{TX} + I _{RX}	-	300	mA

TRANSMITTER ELECTRO-OPTICAL CHARACTERISTICS (V_{CC} = 3.1V to 3.5V, T_C = 0°C to 70°C)

PARAMETER	SYMBOL	MIN	TYP.	MAX	UNIT	NOTES
Output Optical Power 9/125um fiber	P _{out}	0	-	+5	dBm	Average
Extinction Ratio	ER	7	-	-	dB	
Center Wavelength (1270nm)	λ _c	1264.5	-	1277.5	nm	
Center Wavelength (1290nm)		1284.5	-	1297.5		
Center Wavelength (1310nm)		1304.5	-	1317.5		
Center Wavelength (1330nm)		1324.5	-	1337.5		
Center Wavelength (1350nm)		1344.5	-	1357.5		
Center Wavelength (1370nm)		1364.5	-	1377.5		
Center Wavelength (1390nm)		1384.5	-	1397.5		
Center Wavelength (1410nm)		1404.5	-	1417.5		
Center Wavelength (1430nm)		1424.5	-	1437.5		
Center Wavelength (1450nm)		1444.5	-	1457.5		
Spectral Width (-20dB)		Δλ	-	-		1
Side Mode Suppression Ratio	SMSR	30			dB	
Rise/Fall Time, (20~80%)	T _{r,f}	-	-	260	ps	
Relative Intensity Noise	RIN	-	-	-120	dB/Hz	
Total Jitter	TJ	-	-	227	ps	
Output Eye		Compliant with IEEE802.3ae				
Differential Input Voltage	V _{DIFF}	0.4	-	2.0	V	
Max. P _{out} TX-DISABLE Asserted	P _{OFF}	-	-	-45	dBm	

RECEIVER ELECTRO-OPTICAL CHARACTERISTICS (V_{CC} = 3.1V to 3.5V, T_C = 0°C to 70°C)

PARAMETER	SYMBOL	MIN	TYP.	MAX	UNIT	NOTES
Optical Input Power – maximum	P _{IN}	-9	-	-	dBm	BER<10 ⁻¹²
Optical Input Power – minimum (Sensitivity)	P _{IN}	-	-34	-32	dBm	BER<10 ⁻¹²
Operating Center Wavelength	λ _C	1260	-	1620	nm	
Optical Return Loss	ORL	12	-	-	dB	
Signal Detect-Asserted	P _A	-	-	-32	dBm	
Signal Detect-Deasserted	P _D	-40	-	-	dBm	
Differential Output Voltage	V _{DIFF}	0.5	-	1.2	V	
Data Output Rise, Fall Time (20~80%)	T _{r,f}	-	-	0.35	ns	
Receiver Loss of Signal Output Voltage-Low	RX_LOS _L	0	-	0.5	V	
Receiver Loss of Signal Output-High	RX_LOS _H	2.4	-	V _{CC}	V	

BLOCK DIAGRAM OF TRANSCEIVER

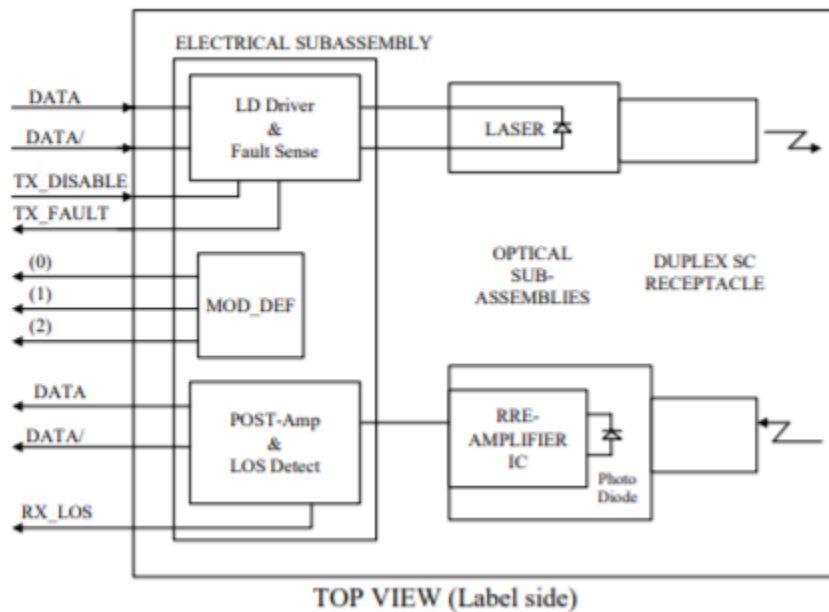

Transmitter Section - The transmitter section consists of a 1310 nm InGaAsP laser in an eye safe optical subassembly (OSA) which mates to the fiber cable. The laser OSA is driven by a LD driver IC which converts differential input LVPECL logic signals into an analog laser driving current.

TX_DISABLE - The TX_DISABLE signal is high (TTL logic “1”) to turn off the laser output. The laser will turn on when TX_DISABLE is low (TTL logic “0”).

Receiver Section - The receiver utilizes an APD photodiode mounted together with a trans-impedance preamplifier IC in an OSA. This OSA is connected to a circuit providing post-amplification quantization, and optical signal detection.

Receive Loss (RX_LOS) - The RX_LOS is high (logic “1”) when there is no incoming light from the companion transceiver. This signal is normally used by the system for the diagnostic purpose. The signal is operated in LVTTTL level.

DIMENSIONS

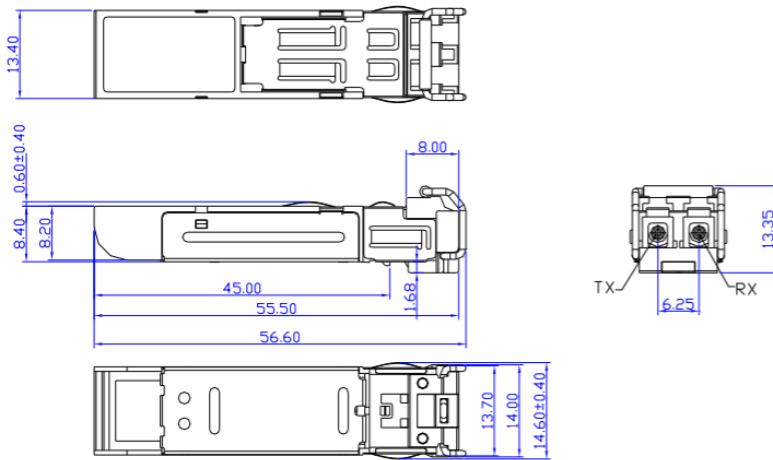

DIMENSIONS ARE IN MILLIMETERS

ALL DIMENSIONS ARE ± 0.2mm UNLESS OTHERWISE SPECIFIED

SFP HOST BOARD MECHANICAL LAYOUT

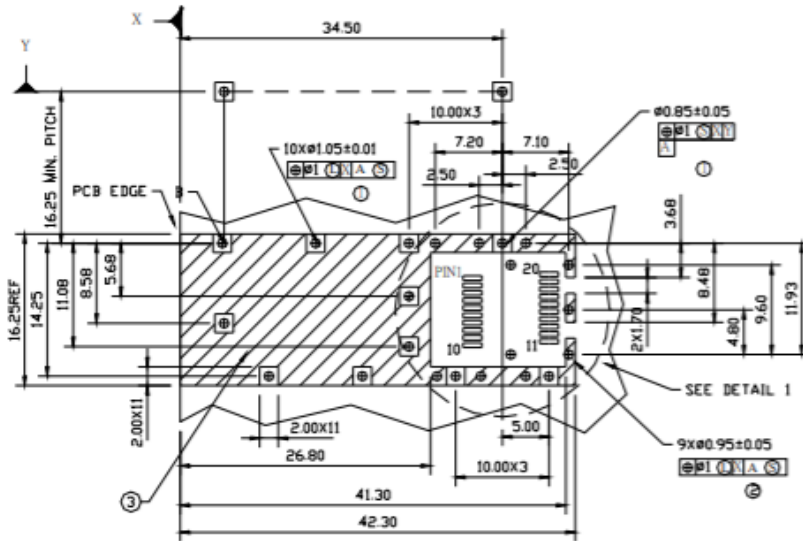

LEGEND

- 1. PADS AND VIAS ARE CHASSIS GROUND
- 2. THROUGH HOLES, PLATING OPTIONAL
- 3. HATCHED AREA DENOTES COMPONENT AND TRACE KEEPOUT (EXCEPT CHASSIS GROUND)
- 4. AREA DENOTES COMPONENT KEEPOUT (TRACES ALLOWED)

DIMENSIONS ARE IN MILLIMETERS

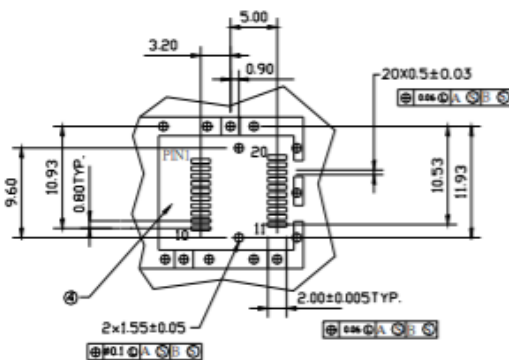

ASSEMBLY DRAWING (unit: mm)

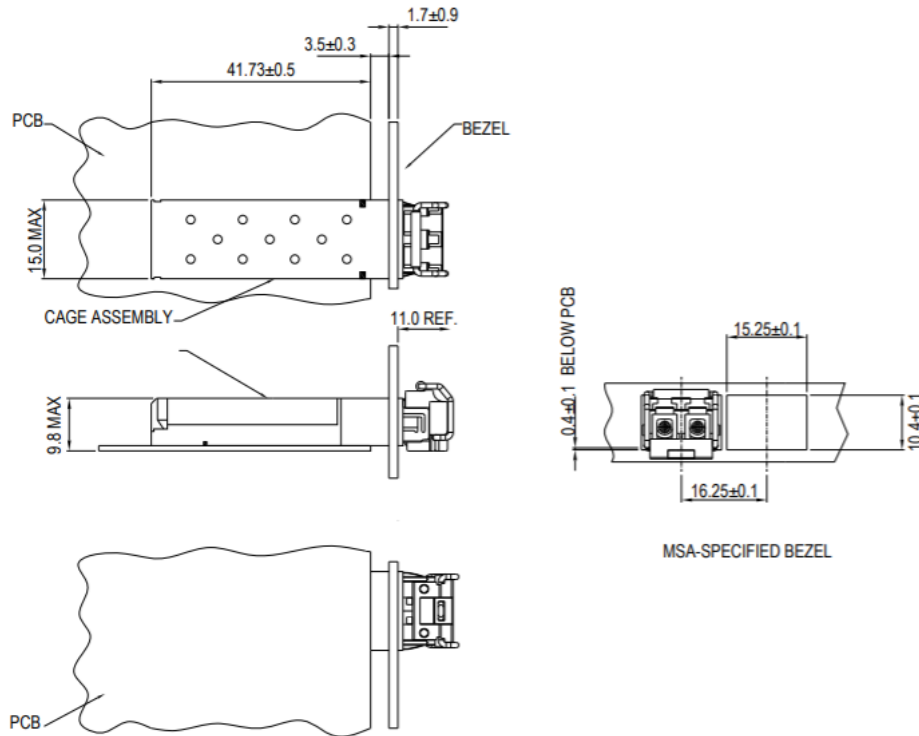

PIN ASSIGNMENT

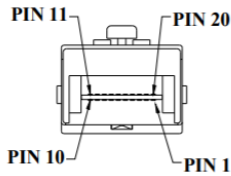

PIN	SIGNAL NAME	DESCRIPTION	PIN	SIGNAL NAME	DESCRIPTION
1	T _{GND}	Transmit Ground	11	R _{GND}	Receiver Ground
2	TX_FAULT	Transmit Fault	12	RX-	Receive Data Bar, Differential PECL, ac coupled
3	TX_DISABLE	Transmit Disable	13	RX+	Receive Data, Differential PECL, ac coupled
4	MOD_DEF (2)	SDA Serial Data Signal	14	R _{GND}	Receiver Ground
5	MOD_DEF (1)	SCL Serial Clock Signal	15	V _{CCR}	Receiver Power Supply
6	MOD_DEF (0)	TTL Low	16	V _{CCT}	Transmitter Power Supply
7	RATE SELECT	Open Circuit	17	T _{GND}	Transmitter Ground
8	RX_LOS	Receiver Loss of Signal, TTL High, open collector	18	TX+	Transmit Data, Differential PECL, ac coupled
9	R _{GND}	Receiver Ground	19	TX-	Transmit Data Bar, Differential PECL, ac coupled
10	R _{GND}	Receiver Ground	20	T _{GND}	Transmitter Ground

EYE SAFETY MARK

The single-mode transceiver is a class 1 laser product. It complies with EN 60825-1 and FDA 21 CFR 1040.10 and 1040.11. In order to meet laser safety requirements, the transceiver shall be operated within the Absolute Maximum Ratings.

Required Mark

Class 1 Laser Product
Complies with
21 CFR 1040.10 and 1040.11

[Caution] All adjustments have been done at the factory before the shipment of the devices. No maintenance and user serviceable part is required. Tampering with and modifying the performance of the device will result in voided product warranty.

ADDITIONAL NOTES

- Avoid eye or skin exposure to laser radiations.
- The device is sensitive to electro-static discharge (ESD). The device should be handled with ESD proof tools. To assemble the device on PCB, proper grounding is required to prevent ESD.
- Specifications are subject to change without notice.



Lasermate Group, Inc.
19608 Camino De Rosa
Walnut, CA 91789 USA
Tel: (909)718-0999
Fax: (909)718-0998
sales@lasermate.com
www.lasermate.com