

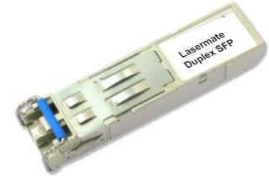

## 2.5Gbps 1310nm SMF 5km SFP Optical Transceiver with Duplex LC Connector

### CS13F-48F-3C-Tx-LD



#### DESCRIPTION

The CS13F-48F-3C-Tx-LD duplex SFP (Small Form Pluggable) optical transceivers are high performance, cost effective optical transceiver modules for serial optical data communications application specified for a data rate of 2.5Gb/s. The SFP transceiver module provides 5km transmission distance over single-mode fiber at nominal wavelength of 1310nm. The optical transceiver is RoHS compliant.

#### FEATURES

- Compliant with SFF8472 diagnostic monitoring interface
- Industry standard small form pluggable (SFP) package
- Multi-Rate
- Hot pluggable
- Single power supply 3.3V
- Duplex LC connector
- Differential LVPECL inputs and outputs
- TTL signal detect indicator
- Class 1 laser product compliant with EN 60825-1
- LD Type: FP
- Input/Output: AC/AC
- Up to 5km over single mode fiber

#### APPLICATIONS

- I-16

#### PRODUCT OVERVIEW

PART NUMBER	OPERATING TEMPERATURE
CS13F-48F-3C-TC-LD	0°C to 70°C
CS13F-48F-3C-TI-LD	-40°C to 85°C

## DIAGNOSTICS

PARAMETER	RANGE	ACCURACY	UNIT	CALIBRATION
Temperature	-40 to 85	±3	°C	External
Voltage	3.1 to 3.5	±0.1	V	
Bias Current	0 to 90	±5	mA	
TX Power	-12 to 0	±3 dB	dBm	
RX Power	-20 to -3	±3 dB	dBm	

## ABSOLUTE MAXIMUM RATINGS

PARAMETER	SYMBOL	MIN	MAX	UNIT
Storage Temperature	T <sub>S</sub>	-40	85	°C
Supply Voltage	V <sub>CC</sub>	-0.5	4.0	V
Input Voltage	V <sub>IN</sub>	-0.5	V <sub>CC</sub>	V

## RECOMMENDED OPERATING CONDITIONS

PARAMETER	SYMBOL	MIN	MAX	UNIT	NOTES
Case Operating Temperature	T <sub>C</sub>	0	70	°C	CS13F-48F-3C-TC-LD
		-40	85		CS13F-48F-3C-TI-LD
Supply Voltage	V <sub>CC</sub>	3.1	3.5	V	
Supply Current	I <sub>TX</sub> + I <sub>RX</sub>	-	250	mA	

TRANSMITTER ELECTRO-OPTICAL CHARACTERISTICS (V<sub>CC</sub> = 3.1V to 3.5V, T<sub>C</sub> = 0°C to 70°C, -40°C to 85°C)

PARAMETER	SYMBOL	MIN	TYP.	MAX	UNIT	NOTES
Output Optical Power 9/125um fiber	P <sub>out</sub>	-9	-	-3	dBm	Average
Extinction Ratio	ER	8.2	-	-	dB	
Center Wavelength	λ <sub>C</sub>	1260	1310	1360	nm	
Spectral Width (RMS)	Δλ	-	-	4	nm	
Output Eye	Compliant with Telcordia GR-253-CORE Issue 3 and ITU-T recommendation G-957					
Max. P <sub>out</sub> TX-DISABLE Asserted	P <sub>OFF</sub>	-	-	-45	dBm	
Differential Input Voltage	V <sub>DIFF</sub>	0.4	-	2.0	V	

RECEIVER ELECTRO-OPTICAL CHARACTERISTICS (V<sub>CC</sub> = 3.1V to 3.5V, T<sub>C</sub> = 0°C to 70°C, -40°C to 85°C)

PARAMETER	SYMBOL	MIN	TYP.	MAX	UNIT	NOTES
Optical Input Power-Maximum	P <sub>IN</sub>	-3	-	-	dBm	BER<10 <sup>-10</sup>
RX Sensitivity @2.67 Gb/s	P <sub>IN</sub>	-	-	-20	dBm	PRBS23, BER<10 <sup>-10</sup>
RX Sensitivity @OC-48	P <sub>IN</sub>	-	-	-20	dBm	PRBS23, BER<10 <sup>-10</sup>
RX Sensitivity @2xFC	P <sub>IN</sub>	-	-	-20	dBm	PRBS7, BER<10 <sup>-12</sup>
RX Sensitivity @GbE	P <sub>IN</sub>	-	-	-20	dBm	PRBS7, BER<10 <sup>-12</sup>
RX Sensitivity @OC-12	P <sub>IN</sub>	-	-	-20	dBm	PRBS23, BER<10 <sup>-10</sup>
RX Sensitivity @OC-3	P <sub>IN</sub>	-	-	-20	dBm	PRBS23, BER<10 <sup>-10</sup>
RX Sensitivity @Fast Ethernet	P <sub>IN</sub>	-	-	-20	dBm	PRBS7, BER<10 <sup>-10</sup>
Operating Center Wavelength	λ <sub>C</sub>	1260	-	1610	nm	
Signal Detect-Asserted	P <sub>A</sub>	-	-	-20	dBm	
Signal Detect-Deasserted	P <sub>D</sub>	-30	-	-	dBm	
Differential Output Voltage	V <sub>DIFF</sub>	0.5	-	1.2	V	
Receiver Loss of Signal Output Voltage-Low	RX_LOS <sub>L</sub>	0	-	0.5	V	
Receiver Loss of Signal Output Voltage-High	RX_LOS <sub>H</sub>	2.4	-	V <sub>CC</sub>	V	

**BLOCK DIAGRAM OF TRANSCEIVER**

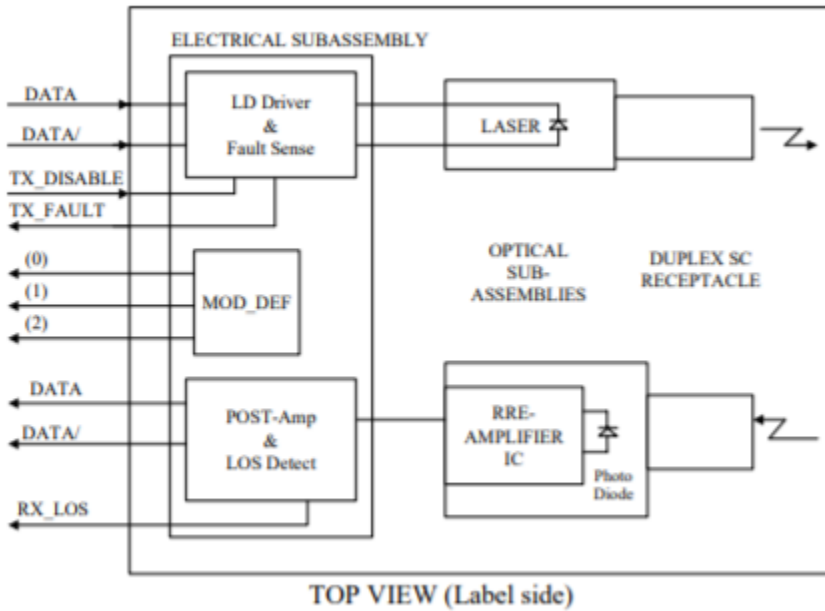

**Transmitter Section** - The transmitter section consists of a 1310 nm InGaAsP laser in an eye safe optical subassembly (OSA) which mates to the fiber cable. The laser OSA is driven by a LD driver IC which converts differential input LVPECL logic signals into an analog laser driving current.

**TX\_DISABLE** - The TX\_DISABLE signal is high (TTL logic “1”) to turn off the laser output. The laser will turn on when TX\_DISABLE is low (TTL logic “0”).

**Receiver Section** - The receiver utilizes an InGaAs PIN photodiode mounted together with a trans-impedance preamplifier IC in an OSA. This OSA is connected to a circuit providing post-amplification quantization, and optical signal detection.

**Receive Loss (RX\_LOS)** - The RX\_LOS is high (logic “1”) when there is no incoming light from the companion transceiver. This signal is normally used by the RX system for the diagnostic purpose. The signal is operated in LVTTTL level.

**DIMENSIONS**

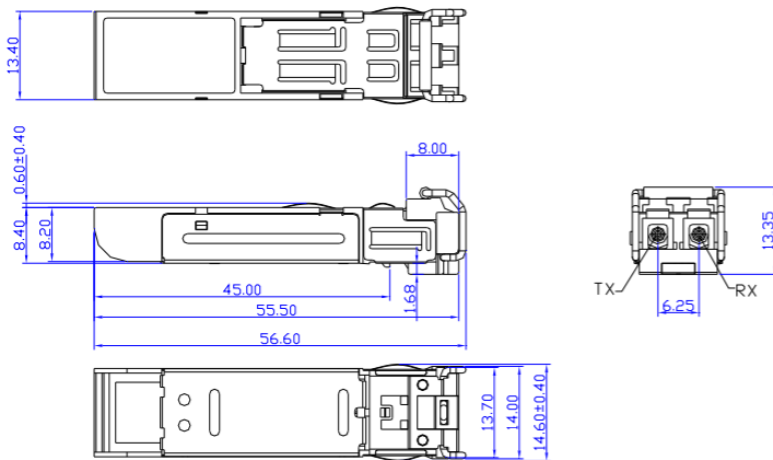

**DIMENSIONS ARE IN MILLIMETERS**

**ALL DIMENSIONS ARE ± 0.2mm UNLESS OTHERWISE SPECIFIED**



## PIN ASSIGNMENT

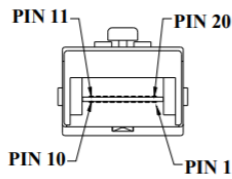

PIN	SIGNAL NAME	DESCRIPTION	PIN	SIGNAL NAME	DESCRIPTION
1	T <sub>GND</sub>	Transmit Ground	11	R <sub>GND</sub>	Receiver Ground
2	TX_FAULT	Transmit Fault	12	RX-	Receive Data Bar, Differential PECL, ac coupled
3	TX_DISABLE	Transmit Disable	13	RX+	Receive Data, Differential PECL, ac coupled
4	MOD_DEF (2)	SDA Serial Data Signal	14	R <sub>GND</sub>	Receiver Ground
5	MOD_DEF (1)	SCL Serial Clock Signal	15	V <sub>CCR</sub>	Receiver Power Supply
6	MOD_DEF (0)	TTL Low	16	V <sub>CCT</sub>	Transmitter Power Supply
7	RATE SELECT	Open Circuit	17	T <sub>GND</sub>	Transmitter Ground
8	RX_LOS	Receiver Loss of Signal, TTL High, open collector	18	TX+	Transmit Data, Differential PECL, ac coupled
9	R <sub>GND</sub>	Receiver Ground	19	TX-	Transmit Data Bar, Differential PECL, ac coupled
10	R <sub>GND</sub>	Receiver Ground	20	T <sub>GND</sub>	Transmitter Ground

## ADDITIONAL NOTES

- Avoid eye or skin exposure to laser radiations.
- The device is sensitive to electro-static discharge (ESD). The device should be handled with ESD proof tools. To assemble the device on PCB, proper grounding is required to prevent ESD.
- Specifications are subject to change without notice.



**Lasermate Group, Inc.**  
 19608 Camino De Rosa  
 Walnut, CA 91789 USA  
 Tel: (909)718-0999  
 Fax: (909)718-0998  
[sales@lasermate.com](mailto:sales@lasermate.com)  
[www.lasermate.com](http://www.lasermate.com)