

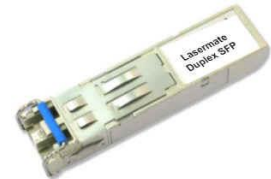

## **2Mbps 1310nm Single Mode 20km SFP IEEE C37.94 Optical Transceiver with Duplex LC Connector**

**CS13-2MF-3C-Tx-L**



### **DESCRIPTION**

The CS13-2MF-3C-Tx-L are high performance, cost-effective optical transceivers for serial optical data communication applications specified for 2Mb/s. The optical transceiver module is a duplex LC connector designed to provide an IEEE C37.94 link for 2Mb/s applications. It provides up to 20km transmission distance over single-mode fiber at nominal wavelength of 1310nm. The optical transceiver is RoHS compliant.

### **FEATURES**

- IEEE C37.94 application
- RoHS compliant
- Compliant with SFF8472 diagnostic monitoring interface
- Duplex LC connector
- Single power supply 3.3V
- Hot pluggable SFP footprint
- Class 1 laser product compliant with EN 60825-1
- TTL signal detect
- Input/Output: AC/AC
- Up to 20km over single mode fiber

### **APPLICATIONS**

- IEEE C37.94

### **PRODUCT OVERVIEW**

<b>PART NUMBER</b>	<b>OPERATING TEMPERATURE</b>
CS13-2MF-3C-TC-L	0°C to 70°C
CS13-2MF-3C-TI-L	-40°C to 85°C

**DIAGNOSTICS**

PARAMETER	RANGE	ACCURACY	UNIT	CALIBRATION
Temperature	-40 to 85	±3	°C	Internal
Voltage	3.1 to 3.5	±0.1	V	
Bias Current	0 to 60	±10%	mA	
TX Power	-19 to -11	±3db	dBm	
RX Power	-32 to -8	±3db	dBm	

**ABSOLUTE MAXIMUM RATINGS**

PARAMETER	SYMBOL	MIN	MAX	UNIT	NOTES
Storage Temperature	T <sub>S</sub>	-40	85	°C	
Supply Voltage	V <sub>CC</sub>	-0.5	4.0	V	
Input Voltage	V <sub>IN</sub>	-0.5	V <sub>CC</sub>	V	

**OPERATING ENVIRONMENT**

PARAMETER	SYMBOL	MIN	MAX	UNIT	NOTES
Case Operating Temperature	T <sub>C</sub>	0	70	°C	CS13-2MF-3C-TC-L
		-40	85		CS13-2MF-3C-TI-L
Supply Voltage	V <sub>CC</sub>	3.1	3.5	V	
Supply Current	I <sub>TX</sub> + I <sub>RX</sub>	-	250	mA	

**TRANSMITTER ELECTRO-OPTICAL CHARACTERISTICS**

PARAMETER	SYMBOL	MIN	TYP.	MAX	UNIT	NOTES
Output Optical Power	P <sub>out</sub>	-19	-	-11	dBm	Average
Extinction Ratio	ER	12	-	-	dB	
Center Wavelength	λ <sub>C</sub>	1290	1310	1350	nm	
Max. P <sub>out</sub> TX-DISABLE Asserted	P <sub>OFF</sub>	-	-	-45	dBm	
Differential Input Voltage	V <sub>DIFF</sub>	0.4	-	2.0	V	

**RECEIVER ELECTRO-OPTICAL CHARACTERISTICS**

PARAMETER	SYMBOL	MIN	TYP.	MAX	UNIT	NOTES
Optical Input Power-Maximum	P <sub>IN</sub>	-8	-	-	dBm	PRBS7, BER<10 <sup>-9</sup>
Receiver Input Power-Minimum (Sensitivity)	P <sub>IN</sub>	-	-	-32	dBm	PRBS7, BER<10 <sup>-9</sup>
Operating Center Wavelength	λ <sub>C</sub>	1260	-	1360	nm	
LOS-Deasserted	P <sub>A</sub>	-	-	-32	dBm	
LOS-Asserted	P <sub>D</sub>	-45	-	-	dBm	
Differential Output Voltage	V <sub>DIFF</sub>	0.6	-	1.8	V	
Receiver Loss of Signal Output Voltage-Low	RX_LOS <sub>L</sub>	0	-	0.5	V	
Receiver Loss of Signal Output Voltage-High	RX_LOS <sub>H</sub>	2.4	-	V <sub>CC</sub>	V	

**DIMENSIONS**

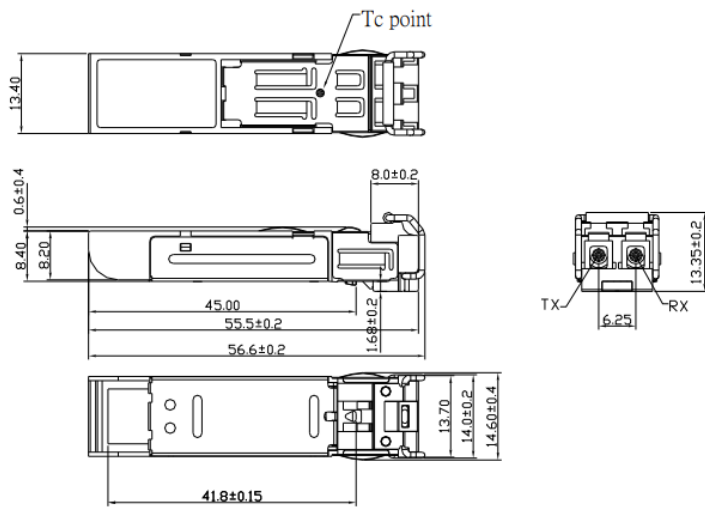

**DIMENSIONS ARE IN MILLIMETERS**  
**ALL DIMENSIONS ARE ± 0.1mm UNLESS OTHERWISE SPECIFIED**

Unit: mm

**SFP HOST BOARD MECHANICAL LAYOUT**

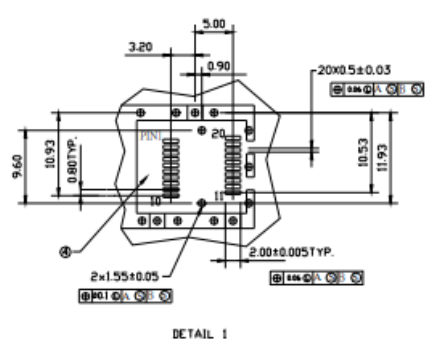
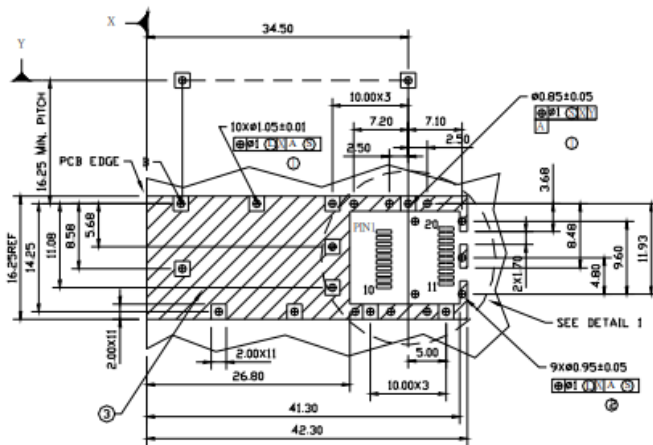

- LEGEND**
- 1.PADS AND VIAS ARE CHASSIS GROUND
  - 2.THROUGH HOLES, PLATING OPTIONAL
  - 3.HATCHED AREA DENOTES COMPONENT AND TRACE KEEPOUT(EXCEPT CHASSIS GROUND)
  - 4.AREA DENOTES COMPONENT KEEPOUT (TRACES ALLOWED)

DIMENSIONS ARE IN MILLIMETERS

Unit: mm

**ASSEMBLY DRAWING**

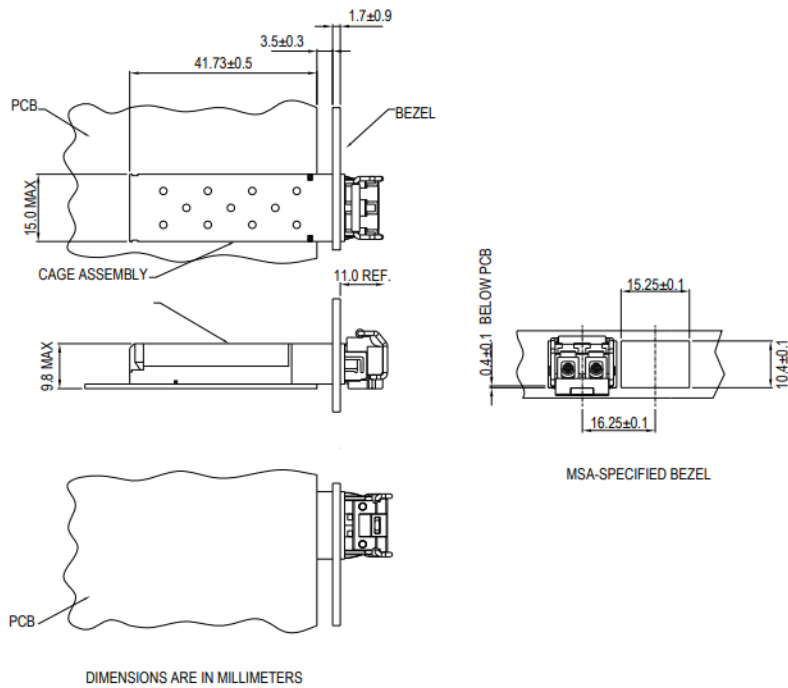

Unit: mm

**PIN ASSIGNMENT**

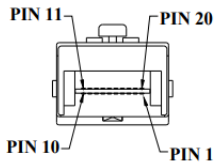

Pin	Signal Name	Description
1	<i>T<sub>GND</sub></i>	Transmit Ground
2	<i>TX_FAULT</i>	Transmit Fault
3	<i>TX_DISABLE</i>	Transmit Disable
4	<i>MOD_DEF (2)</i>	SDA Serial Data Signal
5	<i>MOD_DEF (1)</i>	SCL Serial Clock Signal
6	<i>MOD_DEF (0)</i>	TTL Low
7	<i>RATE_SELECT</i>	Open Circuit
8	<i>RX_LOS</i>	Receiver Loss of Signal, TTL High, open collector
9	<i>R<sub>GND</sub></i>	Receiver Ground
10	<i>R<sub>GND</sub></i>	Receiver Ground
11	<i>R<sub>GND</sub></i>	Receiver Ground
12	<i>RX-</i>	Receive Data Bar, Differential , ac coupled
13	<i>RX+</i>	Receive Data, Differential , ac coupled
14	<i>R<sub>GND</sub></i>	Receiver Ground
15	<i>V<sub>CCR</sub></i>	Receiver Power Supply
16	<i>V<sub>CCT</sub></i>	Transmitter Power Supply
17	<i>T<sub>GND</sub></i>	Transmitter Ground
18	<i>TX+</i>	Transmit Data, Differential , ac coupled
19	<i>TX-</i>	Transmit Data Bar, Differential , ac coupled
20	<i>T<sub>GND</sub></i>	Transmitter Ground

**ADDITIONAL NOTES**

- Avoid eye or skin exposure to laser radiations.
- The device is sensitive to electro-static discharge (ESD). The device should be handled with ESD proof tools. To assemble the device on PCB, proper grounding is required to prevent ESD.
- Specifications are subject to change without notice.



**Lasermate Group, Inc.**  
19608 Camino De Rosa  
Walnut, CA 91789 USA  
Tel: (909)718-0999  
Fax: (909)718-0998  
[sales@lasermate.com](mailto:sales@lasermate.com)  
[www.lasermate.com](http://www.lasermate.com)