



2.048Mbps 850nm Multimode 2km 1x9 IEEE C37.94 Optical Transceiver with Duplex ST Connector

CM85-2MA-3S-PC-T



DESCRIPTION

The CM85-2MA-3S-PC-T are high performance, cost-effective optical transceivers for serial optical data communication applications specified for 2Mb/s. The optical transceiver module is a duplex ST connector designed to provide an IEEE C37.94 link for 2Mb/s applications. It provides up to 2km transmission distance over multi-mode fiber at nominal wavelength of 850nm. The optical transceiver is RoHS compliant.

FEATURES

- IEEE C37.94 application
- RoHS compliant
- Industry standard 1x9 footprint
- ST duplex connector
- Single power supply 3.3V
- Differential LVPECL inputs and outputs
- Class 1 laser product compliant with EN 60825-1
- Input/Output: DC/DC
- Up to 2km over multi-mode fiber

APPLICATIONS

- IEEE C37.94

ABSOLUTE MAXIMUM RATINGS

PARAMETER	SYMBOL	MIN	MAX	UNIT	NOTES
Storage Temperature	T_S	-40	85	°C	
Supply Voltage	V_{CC}	-0.5	4.0	V	
Input Voltage	V_{IN}	-0.5	V_{CC}	V	
Soldering Temperature	T_{SOLD}	-	260	°C	10 seconds on leads

OPERATING ENVIRONMENT

PARAMETER	SYMBOL	MIN	MAX	UNIT	NOTES
Case Operating Temperature	T_C	0	70	°C	
Supply Voltage	V_{CC}	3.1	3.5	V	
Power Supply Current (TX+RX)	I_{CC}	-	200	mA	Not including terminations current
Data Rate	B	2.048		Mb/s	

TRANSMITTER ELECTRO-OPTICAL CHARACTERISTICS

PARAMETER	SYMBOL	MIN	TYP.	MAX	UNIT	NOTES
Output Optical Power 62.5/125um fiber	P_{out}	-19	-	-11	dBm	Average
Output Optical Power 50/125um fiber	P_{out}	-23	-	-11	dBm	Average
Extinction Ratio	ER	10	-	-	dB	
Center Wavelength	λ_C	790	-	870	nm	
Transmitter Data Input Voltage-High	$V_{IH}-V_{CC}$	-1.16	-	-0.88	V	
Transmitter Data Input Voltage-Low	$V_{IL}-V_{CC}$	-1.81	-	-1.48	V	

RECEIVER ELECTRO-OPTICAL CHARACTERISTICS

PARAMETER	SYMBOL	MIN	TYP.	MAX	UNIT	NOTES
Optical Input Power-Maximum	P_{IN}	-11	-	-	dBm	PRBS7, BER<10 ⁻⁹
Receiver Input Power-Minimum (Sensitivity)	P_{IN}	-	-	-32	dBm	PRBS7, BER<10 ⁻⁹
Operating Center Wavelength	λ_C	790	-	870	nm	
Signal Detect-Asserted	P_A	-	-	-32	dBm	
Signal Detect-Deasserted	P_D	-45	-	-	dBm	
Signal Detect Output Voltage-High	$V_{OH}-V_{CC}$	-1.1	-	-0.74	V	
Signal Detect Output Voltage-Low	$V_{OL}-V_{CC}$	-2.0	-	-1.58	V	
Data Output Voltage-High	$V_{OH}-V_{CC}$	-1.1	-	-0.74	V	
Data Output Voltage-Low	$V_{OL}-V_{CC}$	-2.0	-	-1.58	V	

BLOCK DIAGRAM OF TRANSCEIVER

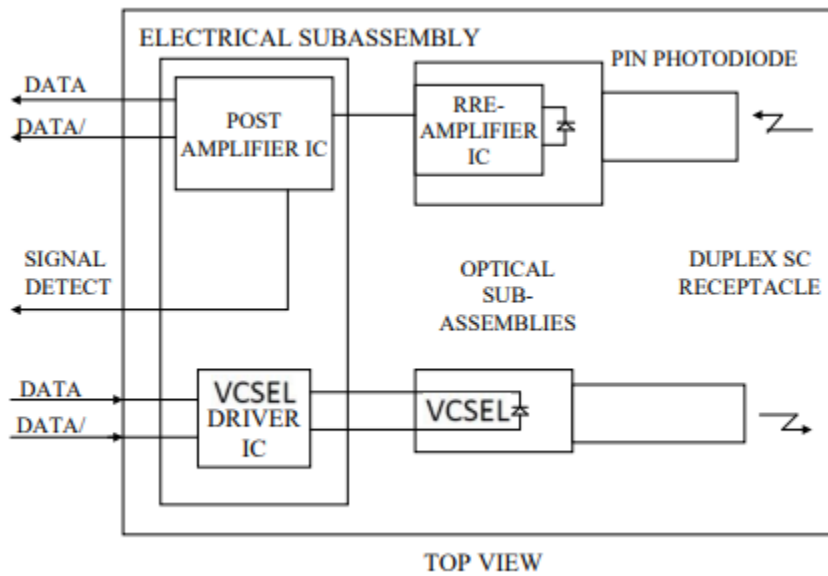

Transmitter Section - The transmitter section consists of a 850nm VCSEL in an eye safe optical subassembly (OSA) which mates to the fiber cable. The laser OSA is driven by a LD driver IC which converts differential input LVPECL logic signals into an analog laser driving current.

Receiver Section - The receiver utilizes a PIN photodiode mounted together with a trans-impedance preamplifier IC in an OSA. This OSA is connected to a circuit providing post-amplification quantization, and optical signal detection.

Receiver Signal Detect - Signal Detect is a basic fiber failure indicator. This is a single-ended LVPECL output. As the input optical power is decreased, Signal Detect will switch from high to low (deassert point) somewhere between sensitivity and the no light input level. As the input optical power is increased from very low levels, Signal Detect will switch back from low to high (assert point).

CONNECTION DIAGRAM

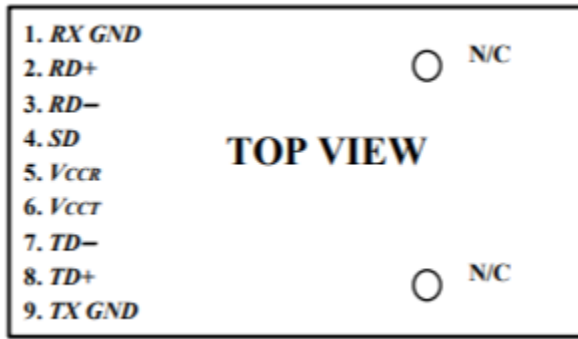

PIN	SYMBOL	DESCRIPTION
1	<i>RX GND</i>	Receiver Signal Ground. Directly connect this pin to the receiver ground plane.
2	<i>RD+</i>	<i>RD+</i> is an open-emitter output circuit. Terminate this high-speed differential LVPECL output with standard LVPECL techniques at the follow-on device input pin. (See recommended circuit schematic)
3	<i>RD-</i>	<i>RD-</i> is an open-emitter output circuit. Terminate this high-speed differential LVPECL output with standard LVPECL techniques at the follow-on device input pin. (See recommended circuit schematic)
4	<i>SD</i>	Signal Detect. Normal optical input levels to the receiver result in a logic “1” output, <i>V_{OH}</i> , asserted. Low input optical levels to the receiver result in a fault condition indicated by a logic “0” output <i>V_{OL}</i> , deasserted Signal Detect is a single-ended LVPECL output. <i>SD</i> can be terminated with LVPECL techniques via 50 Ω to <i>V_{CCR}</i> – 2 V. Alternatively, <i>SD</i> can be loaded with a 180 Ω resistor to <i>RX GND</i> to conserve electrical power with small compromise to signal quality. If Signal Detect output is not used, leave it open-circuited. This Signal Detect output can be used to drive a LVPECL input on an upstream circuit, such as, Signal Detect input or Loss of Signal-bar.
5	<i>V_{CCR}</i>	Receiver Power Supply. Provide +3.3 Vdc via the recommended receiver power supply filter circuit. Locate the power supply filter circuit as close as possible to the <i>V_{CCR}</i> pin.
6	<i>V_{CCT}</i>	Transmitter Power Supply. Provide +3.3 Vdc via the recommended transmitter power supply filter circuit. Locate the power supply filter circuit as close as possible to the <i>V_{CCT}</i> pin.
7	<i>TD-</i>	Transmitter Data In-Bar. Terminate this high-speed differential LVPECL input with standard LVPECL techniques at the transmitter input pin. (See recommended circuit schematic)
8	<i>TD+</i>	Transmitter Data In. Terminate this high-speed differential LVPECL input with standard LVPECL techniques at the transmitter input pin. (See recommended circuit schematic)
9	<i>TX GND</i>	Transmitter Signal Ground. Directly connect this pin to the transmitter signal ground plane. Directly connect this pin to the transmitter ground plane.

RECOMMENDED CIRCUIT SCHEMATIC

DC/DC Coupling

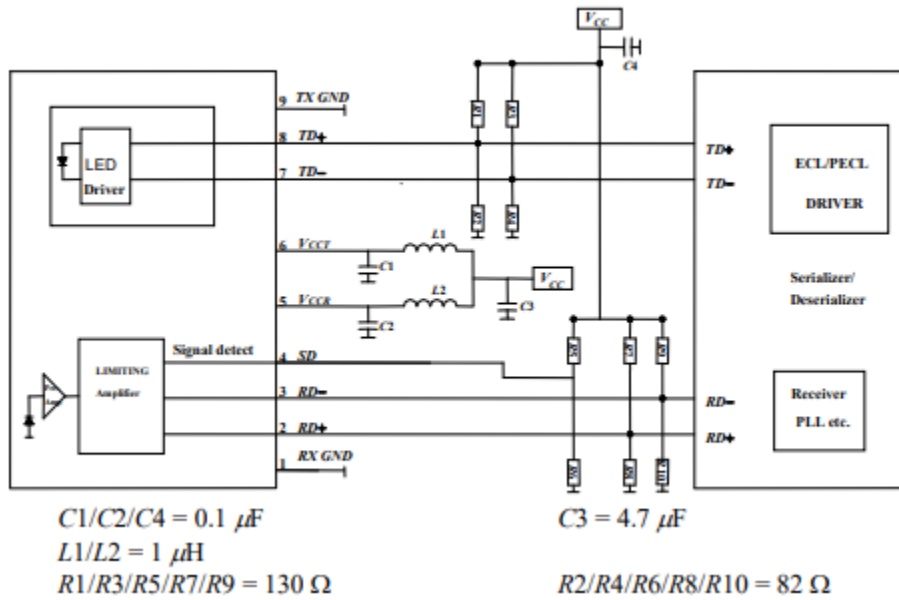

RECOMMENDED BOARD LAYOUT HOLE PATTERN

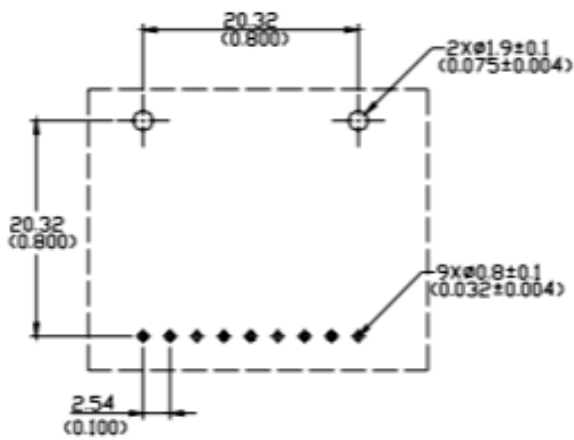

Unit : mm(inches)

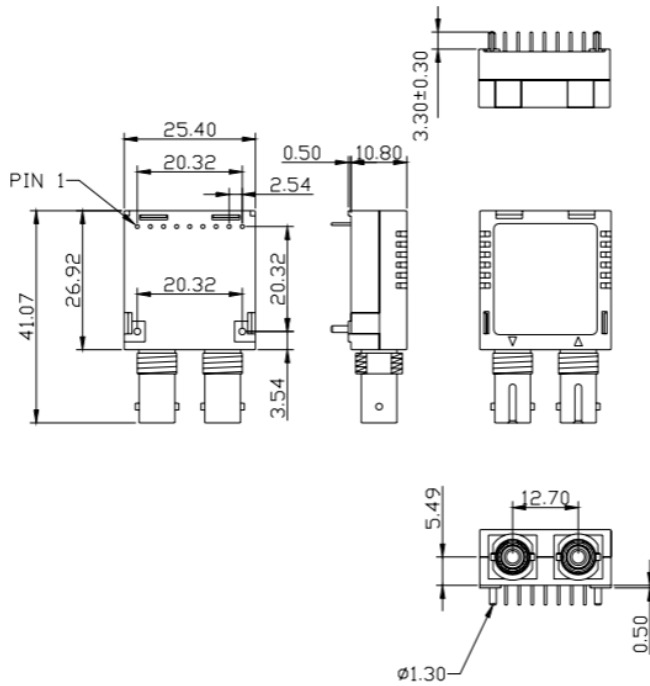
DRAWING DIMENSIONS (unit: mm)

ALL DIMENSIONS ARE $\pm 0.20\text{mm}$ UNLESS OTHERWISE SPECIFIED

ADDITIONAL NOTES

- Avoid eye or skin exposure to laser radiations.
- The device is sensitive to electro-static discharge (ESD). The device should be handled with ESD proof tools. To assemble the device on PCB, proper grounding is required to prevent ESD.
- Specifications are subject to change without notice.



Lasermate Group, Inc.
 19608 Camino De Rosa
 Walnut, CA 91789 USA
 Tel: (909)718-0999
 Fax: (909)718-0998
sales@lasermate.com
www.lasermate.com