



40GBASE-LR4 SMF 10km 1310nm CWDM QSFP+ Optical Transceiver with Duplex LC Connector

40GSLRSFPC



DESCRIPTION

The 40GSLRSFPC QSFP+ 40GBASE-LR4 transceiver is a new high-speed module with a LC connector. This interconnecting module offers 4 channels and maximum bandwidth of 40Gbps. The optical transceiver module consists of 4x10Gbps CWDM LDs and multiplex 4 CWDM signals on a 40Gbps optical transmission, and de-multiplex 40G receiver signals to 4 CWDM signals.

FEATURES

- Compliant with 40G Ethernet IEEE 802.3ba
- Power dissipation < 3.5W
- Full Digital Diagnostics Monitor Interface
- Up to 10km transmission on SMF
- RoHS-6 Compliant (lead-free)
- Class 1 Laser Product compliant with IEC/EN60825-1: 2007 and IEC/EN60825-1: 2014

APPLICATIONS

- 40G Ethernet
- OTN OTU3
- Data Center Interconnect
- 40GBASE-LR4

ABSOLUTE MAXIMUM RATINGS

PARAMETER	SYMBOL	MIN	MAX	UNIT
Storage Temperature	T_S	-40	85	°C
Supply Voltage	V_{CC}	-0.5	3.6	V
Relative Humidity	RH	5	85	%

RECOMMENDED OPERATING CONDITIONS

PARAMETER	SYMBOL	MIN	TYP.	MAX	UNIT
Case Temperature	T_C	0		70	°C
Power Supply Voltage	V_{CC}	3.135	3.3	3.47	V
Power Dissipation				3.5	W

DIAGNOSTICS

PARAMETER	RANGE	ACCURACY	UNIT	CALIBRATION
Temperature	-5 to 75	±5	°C	Internal
Voltage	3.0 to 3.6	±0.1	V	
Bias Current	15 to 70	±10%	mA	
TX Power	-7 to +2.3	±3 dB	dBm	
RX Power	-14.4 to 2.5	±3 dB	dBm	

TRANSMITTER OPTICAL CHARACTERISTICS

PARAMETER	SYMBOL	MIN	TYP.	MAX	UNIT	NOTE
Total Average Launch Power	P_t			8.3	dBm	
Extinction Ratio	ER	3.5			dB	
Center Wavelength	L0	1264.5	1271	1277.5	nm	
	L1	1284.5	1291	1297.5		
	L2	1304.5	1311	1317.5		
	L3	1324.5	1331	1337.5		
Average Output Power	P_o	-7		2.3	dBm	1
Optical Modulation Amplitude, per lane	OMA	-4		3.5	dBm	
Difference in Power between any Two Lanes				6.5	dB	
Side Mode Suppression	SMSR	30			dB	
Relative Intensity Noise	RIN20OMA			-128	dB/Hz	
Transmitter Reflectance	R_T			-12	dB	
Transmitter and Dispersion Penalty	TDP			2.3	dB	
Differential Input Voltage	V_{DIFF}	0.2	-	0.8	V	
Disable Output Power	P_{o_off}			-30	dBm	
Output Eye Mask		Compliant with IEEE 802.3ba				

Note 1: Minimum value is informative.

RECEIVER OPTICAL CHARACTERISTICS

PARAMETER	SYMBOL	MIN	TYP.	MAX	UNIT	NOTE
Damage Threshold, per lane	P _{th}	3.3			dBm	
Average Power at Receiver Input, per lane	P _{IN}	-13.7		2.3	dBm	
Receiver Power (OMA), per lane				3.5	dBm	
Receiver Sensitivity (OMA), per lane	R _{sens}			-11.5	dBm	
Stressed Receiver Sensitivity, per lane				-9.6	dBm	
Differential Input Voltage	V _{DIFF}	0.4	-	0.85	V	
LOS Assert	LOS _A	-28			dBm	1
LOS De-Assert	LOS _D			-15	dBm	1
Receiver Electrical 3dB Upper Cutoff Frequency				12	GHz	
Hysteresis	Hys	0.5		6	dB	
Receiver Reflectance	R _R			-26.0	dB	

Note 1: Average power, Rx output will not be squelched if LOS asserted.

ELECTRICAL CHARACTERISTICS

PARAMETER	SYMBOL	MIN	TYP.	MAX	UNIT	NOTE
Data Rate, per lane			10.3125		Gbps	
LP Mode/Reset/ModselL	V _{IL}	0		0.8	V	
LP Mode/Reset/ModselL	V _{IH}	2		V _{CC} +0.3	V	
ModPrsL/IntL	V _{OL}	0		0.4	V	
ModPrsL/IntL	V _{OH}	2		V _{CC} +0.3	V	

TIMING FOR SOFT CONTROL/STATUS FUNCTION/SQUELCH & DISABLE

PARAMETER	SYMBOL	MIN	TYP.	MAX	UNIT
Initialization Time	T _{init}			2000	ms
Reset Init Assert Time	T _{reset_init}			2	us
Serial Bus Hardware Ready Time	T _{serial}			2000	ms
Monitor Data Ready Time	T _{data}			2000	ms
Reset Assert Time	T _{reset}			2000	ms
LP Mode Assert Time	T _{on_LPMode}			100	us
LP Mode Deassert Time	T _{off_LPMode}			300	ms
IntL Assert Time	T _{on_IntL}			200	ms
IntL Deassert Time	T _{off_IntL}			500	us
Rx LOS Assert Time	T _{on_los}			100	ms
Tx Fault Assert Time	T _{on_Txfault}			200	ms
Flag Assert Time	T _{on_flag}			200	ms
Tx Squelch Assert Time	T _{on_Txsq}			400	ms
Tx Squelch Deassert Time	T _{off_Txsq}			400	ms
Tx Disable Assert Time	T _{on_Txdis}			100	ms
Tx Disable Deassert Time	T _{off_Txdis}			400	ms

DIMENSIONS (unit: mm)

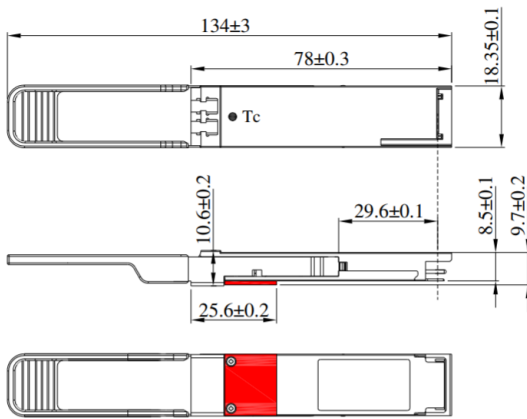

PAD ASSIGNMENT AND DESCRIPTION

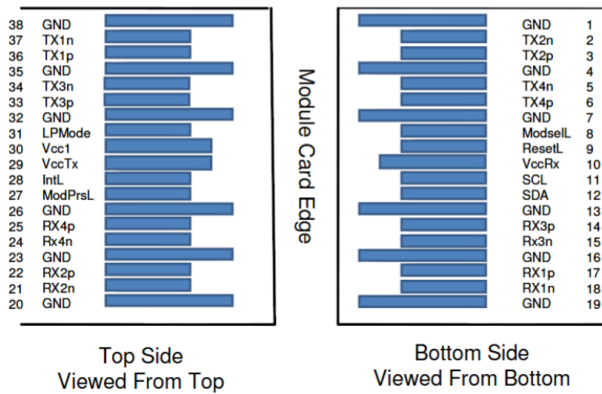

Top Side
Viewed From Top

Bottom Side
Viewed From Bottom

"PIN	LOGIC	SYMBOL	DESCRIPTION	PLUG SEQUENCE	NOTE
1		GND	Ground	1	Note 1
2	CML-I	Tx2n	Transmitter Inverted Data Input	3	
3	CML-I	Tx2p	Transmitter Non-Inverted Data Input	3	
4		GND	Ground	1	Note 1
5	CML-I	Tx4n	Transmitter Inverted Data Input	3	
6	CML-I	Tx4p	Transmitter Non-Inverted Data Input	3	
7		GND	Ground	1	Note 1
8	LVTTL-I	ModSelL	Module Select	3	
9	LVTTL-I	ResetL	Module Reset	3	
10		Vcc Rx	+3.3V Power Supply Receiver	2	Note 2
11	LVC MOS-I/O	SCL	2-wire serial interface clock	3	
12	LVC MOS-I/O	SDA	2-wire serial interface data	3	
13		GND	Ground	1	Note 2
14	CML-O	Rx3p	Receiver Non- Inverted Data Output	3	
15	CML-O	Rx3n	Receiver Inverted Data Output	3	
16		GND	Ground	1	Note 1
17	CML-O	Rx1p	Receiver Non- Inverted Data Output	3	
18	CML-O	Rx1n	Receiver Inverted Data Output	3	

19		GND	Ground	1	Note 1
20		GND	Ground	1	Note 1
21	CML-O	Rx2n	Receiver Inverted Data Output	3	
22	CML-O	Rx2P	Receiver Non- Inverted Data Output	3	
23		GND	Ground	1	Note 1
24	CML-O	Rx4n	Receiver Inverted Data Output	3	
25	CML-O	Rx4p	Receiver Non- Inverted Data Output	3	
26		GND	Ground	1	Note 1
27	LVTTL-O	ModPrsL	Module Present	3	
28	LVTTL-O	IntL	Interrupt	3	
29	LVC MOS-I/O	Vcc Tx	+3.3V Power Supply transmitter	2	Note 2
30		Vcc1	+3.3V Power Supply	2	Note 2
31	LVTTL-I	LPMODE	Low Power Mode	3	
32		GND	Ground	1	Note 1
33	CML-I	Tx3p	Transmitter Non- Inverted Data Input	3	
34	CML-I	Tx3n	Transmitter Inverted Data Input	3	
35		GND	Ground	1	Note 1
36	CML-I	Tx1p	Transmitter Non- Inverted Data Input	3	
37	CML-I	Tx1n	Transmitter Inverted Data Input	3	
38		GND	Ground	1	Note 1

Note 1: GND is the symbol for signal and supply (power) common for the QSFP module. All are common within the QSFP+ module and all module voltages are referenced to this potential unless otherwise noted. Connect these directly to the host board signal-common ground plane.

Note 2: Vcc Rx, Vcc1 and Vcc Tx are the receiver and transmitter power supplies and shall be applied concurrently. Requirements defined for the host side of the Host Edge Card Connector are listed in Table. Recommended host board power supply filtering is shown in Host board power supply circuit. Vcc Rx Vcc1 and Vcc Tx may be internally connected within the QSFP+ module in any combination. The connector pins are each rated for a maximum current of 500 mA.

HOST BOARD POWER SUPPLY CIRCUIT

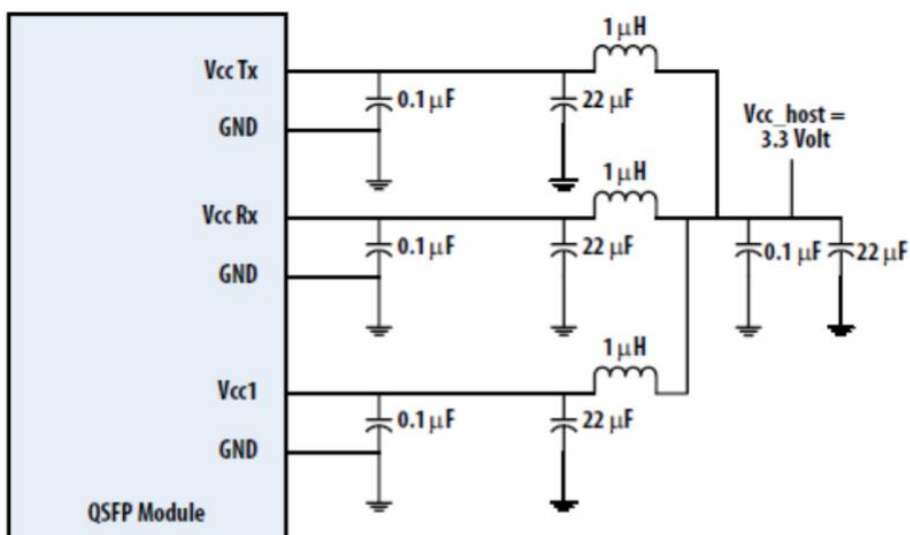

RECOMMENDED INTERFACE CIRCUIT

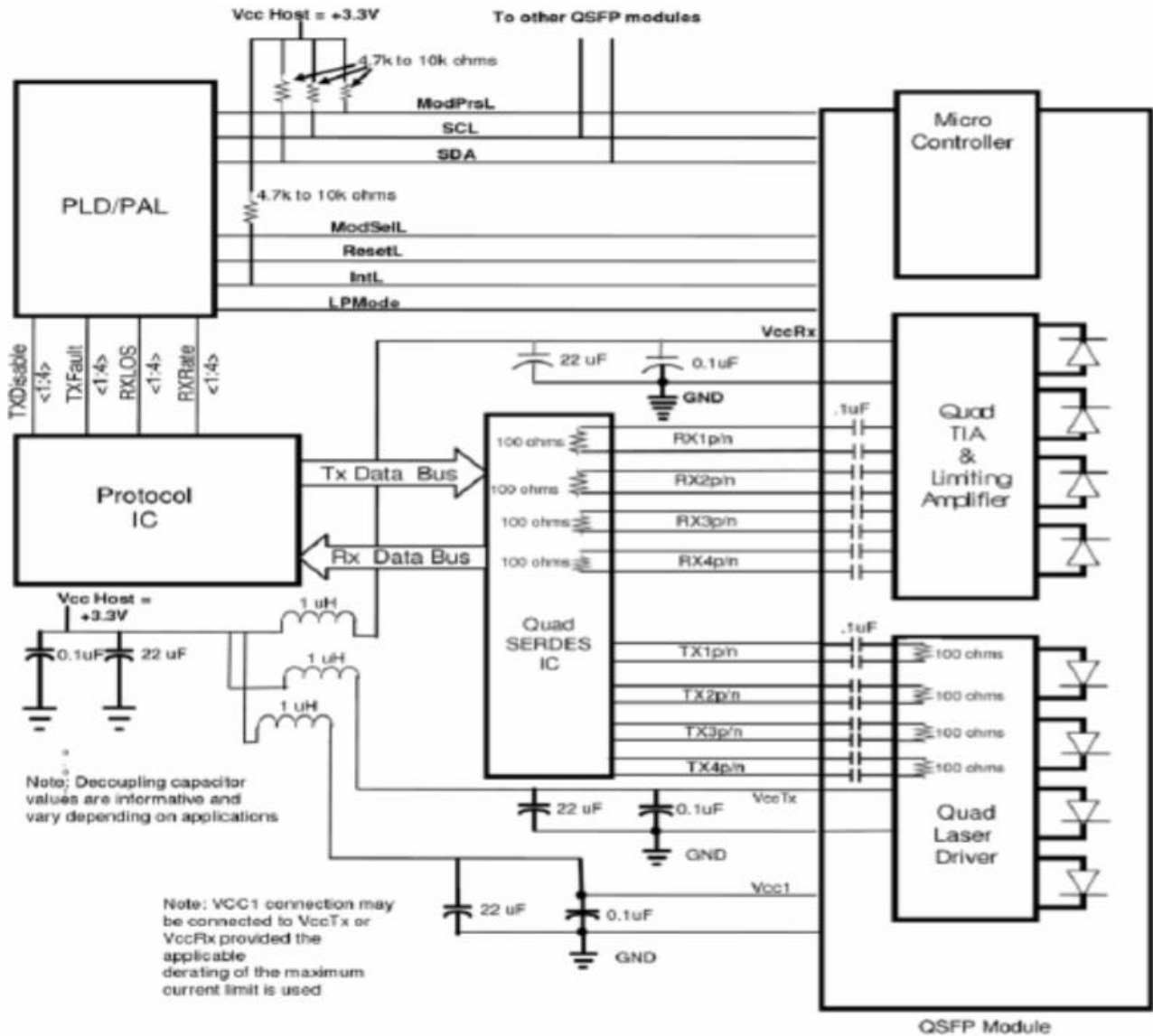

MEMORY MAP

The memory map is structured as a single address and multiple page approaches, according to the QSFP+ SFF-8436 MSA specification as shown in the below. For more detailed description of this memory map or lower pages, please see our Memory Map document with flexible customization settings.

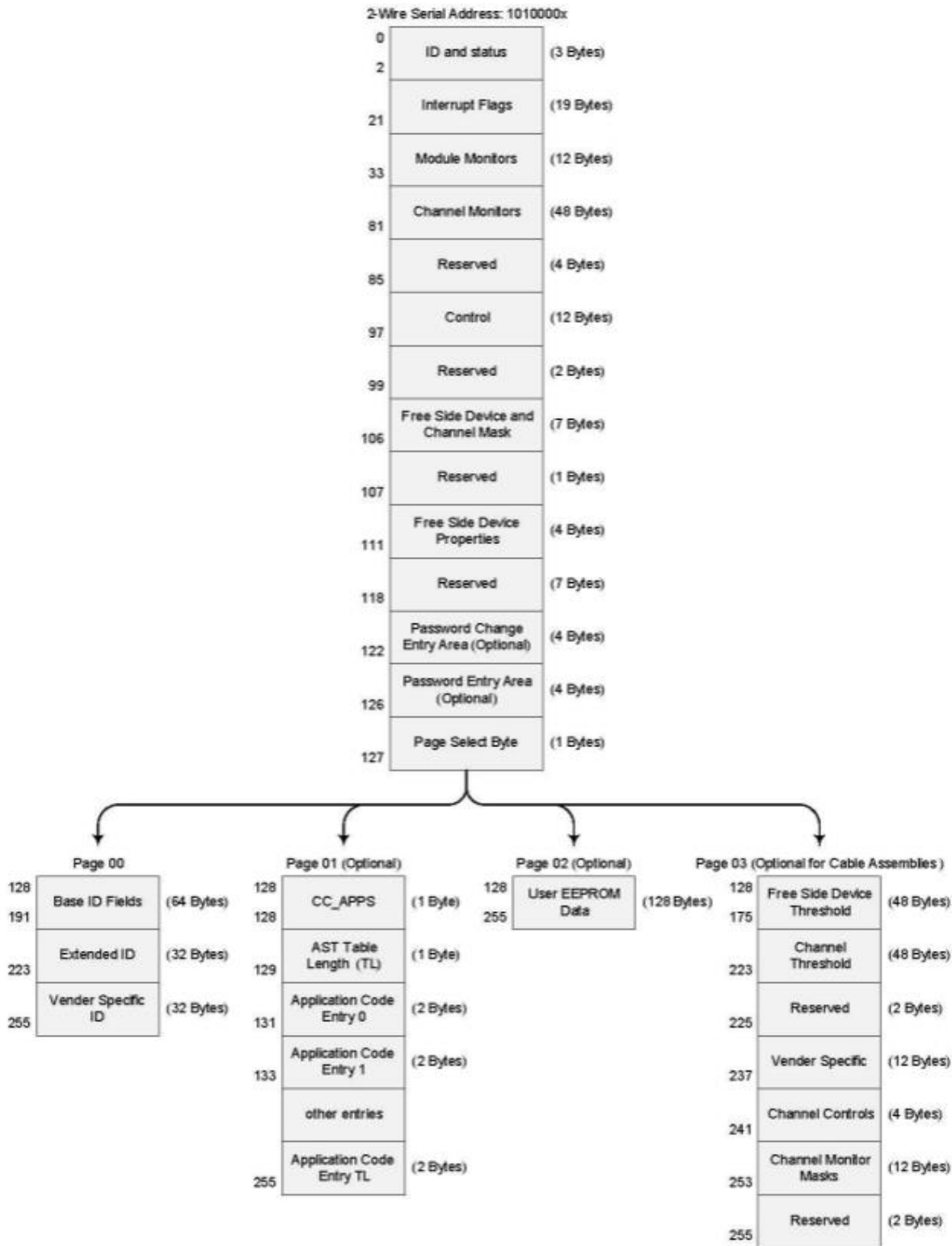

EEPROM Serial ID Memory Contents (2-Wire Address A0h)

Low Memory (00~127)

Address	Description	Hex	Real Value
0	Identifier	0D	
1-2	Status	00,00	
3-21	Interrupt Flags		
22-23	Temperature Monitor		
24-25	Reserved	00,00	
26-27	Supply Voltage Monitor		
28-29	Reserved	00,00	
30-33	Vender specific	00,00,00,00	
34-35	RX1 Power Monitor		
36-37	RX2 Power Monitor		
38-39	RX3 Power Monitor		
40-41	RX4 Power Monitor		
42-43	TX1 Bias Monitor		
44-45	TX2 Bias Monitor		
46-47	TX3 Bias Monitor		
48-49	TX4 Bias Monitor		
50-57	Reserve Channel Monitor set		
58-65	Reserve Channel Monitor set		
66-81	Vender Specific	00,00,00,00,00,00,00,00, 00,00,00,00,00,00,00,00,	
82-85	Reserved	00,00,00,00	
86-97	Control (R/W)		
98-99	Reserved	00,00	
100-106	Module and Channel Masks (R/W)		
107-118	Reserved (12)	00,00,00,00,00,00,00,00,00,00,00,00, 00	
119-122	Password Change Entry Area	00,00,00,00	
123-126	Password Entry Area	00,00,00,00	
127	Page Select Byte	00	

Address	Description	Hex	Real Value
128	Identifier	0D	QSFP+
129	Ext. Identifier	C0	
130	Connector	07	LC Connector
131	Specification Compliance	02	40GBASE-LR4
132		00	
133		00	
134		00	
135		00	
136		00	
137		00	
138		00	
139		Encoding	05
140	BR, nominal	00	
141	Extended rate select Compliance	00	
142	Length(SMF)	0A	10km
143	Length(OM3 50 um)	00	Not compliant
144	Length(OM2 50 um)	00	Not compliant
145	Length(OM1 62.5 um)	00	Not compliant
146	Length(Copper)	00	Not compliant
147	Device tech	40	1310nm DFB
148-163	Vendor name	41, 50, 41, 43, 20, 4F, 70, 74, 6F, 20, 20, 20, 20, 20, 20, 20	APAC Opto
164	Extended Module	00	
165-167	Vendor OUI	00, 00, 00	
168-183	Vendor PN	4C, 53, 33, 43, 4B, 33, 53, 54, 43, 4E, 41, 41, 20, 20, 20, 20	LS3C-K3S-TC-N-AA
184-185	Vendor rev	00,00	Unspecified
186-187	Wave length or Copper cable Attenuation	65, A4	1310nm
188-189	Wavelength tolerance	05, 14	±6.5nm
190	Max case temp.	46	70°C

191	CC_BASE		Check sum of byte 128 ~ 190
192-195	Options	00, 00, 08, 00	
196-211	Vendor SN		
212-219	Date Code		
220	Diagnostic Monitoring Type	08	Average Power
221	Enhanced Options	00	Not compliant
222	Reserved	00	
223	CC_EXT		Check sum of byte 192 ~ 222
224-255	Vendor Specific		

Address	Description	Hex	Real Value
128-129	Temp high alarm	50,00	80°C
130-131	Temp low alarm	F6,00	-10°C
132-133	Temp high warning	4B,00	75°C
134-135	Temp low warning	FB,00	-5°C
144-145	Vcc high alarm	90,88	3.7V
146-147	Vcc low alarm	71,70	2.9V
148-149	Vcc high warning	8C,70	3.6V
150-151	Vcc low warning	75,48	3.0V
176-177	Rx power high alarm	6E,18	4.5dBm
178-179	Rx power low alarm	00,E5	-16.4dBm
180-181	Rx power high warning	45,77	2.5dBm
182-183	Rx power low warning	01,6B	-14.4dBm
184-185	Tx bias high alarm	92,7C	75mA
186-187	Tx bias low alarm	13,88	10mA
188-189	Tx bias high warning	88,B8	70mA
190-191	Tx bias low warning	1D,4C	15mA
192-193	Tx power high alarm	53,83	3.3dBm
194-195	Tx power low alarm	05,E9	-8.2dBm
196-197	Tx power high warning	42,56	2.3dBm
198-199	Tx power low warning	07,CB	-7dBm

200-207	Reserved thresholds for channel parameter set		
208-223	Vender Specific		
224-225	Reserved		
226-237	Vender Specific		
238	RX1/RX2 output amplitude	00,00	200-400mV(p-p)
239	RX3/RX4 output amplitude	00,00	200-400mV(p-p)
240	Squelch Control Bits(not implement)		
241	Rx Output Disable Control(not implement)		
242-253	Channel Monitor Masks		
254-255	Reserved		

EYE SAFETY MARK

The Single-mode transceiver is a class 1 laser product. It complies with EN 60825-1 and FDA 21 CFR 1040.10 and 1040.11. In order to meet laser safety requirements, the transceiver shall be operated within the Absolute Maximum Ratings.

Required Mark

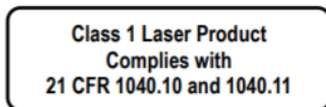

[Caution]

All adjustments have been done at the factory before the shipment of the devices. No maintenance and user serviceable part is required. Tampering with and modifying the performance of the device will result in voided product warranty.

Use of controls or adjustment or performance of procedures other than those specified herein may result in hazardous radiation exposure.

Complies with FDA performance standards for laser products except for deviations pursuant to Laser Notice No. 50.

ADDITIONAL NOTES

- Avoid eye or skin exposure to laser radiations.
- The device is sensitive to electro-static discharge (ESD). The device should be handled with ESD proof tools. To assemble the device on PCB, proper grounding is required to prevent ESD.
- Specifications are subject to change without notice.



Lasermate Group, Inc.
19608 Camino De Rosa
Walnut, CA 91789 USA
Tel: (909)718-0999
Fax: (909)718-0998
sales@lasermate.com
www.lasermate.com