

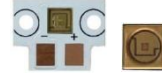

940nm 6000mW CW VCSEL Diode

VCx-940C6WA



Description

The Lasermate VCx-940C6WA is an 940nm wavelength, 6000mW output power, CW operating mode, Vertical Cavity Surface Emitting Laser (VCSEL) diode. Available in different package types, the VCSEL is characterized by its single wavelength, low threshold current, and easy collimation. VCx-940C6WA is designed for use in Proximity sensor, consumer electronics, active optical cables, medical, range finder sensors.

Features

- 940nm VCSEL Diode
- Output power: 6000mW
- Single wavelength
- Low wavelength drift
- Oxide isolation technology
- Low threshold current
- Easy to collimate

Applications

- Proximity sensor
- Consumer electronics
- Active optical cables
- Medical applications
- Range finder sensors

Product Overview

The following table lists the available part numbers, as well as the package type of each of the part numbers.

Part Number	Package
VCTMC-940C6WA	T-Mount Package, Substrate Cu
VC68A-940C6WA	6868 Package, Substrate AlN

Specifications

Absolute Maximum Ratings				
Parameters	Symbol	Rating	Unit	Conditions
Case Operating Temperature	Top	-20 to 85	°C	
Storage Temperature	Tstg	-40 to 105	°C	
Reflow Soldering Temperature	Tsol	260	°C	5 seconds
Reverse Voltage	Vr	5	V	
Maximum Continuous Current	I _{max}	12	A	
ESD Exposure (Human Body) Model	ESD	8K	V	

Notes:

- Stresses greater than those listed under “Absolute Maximum Ratings” may cause permanent damage to the device. This is a stress rating only and functional operation of the device at these or other conditions above those indicated in the operations section for expanded periods of time may affect reliability.
- In its maximum rating diode laser operation could damage its performance or cause potential safety hazard such as equipment failure.
- Electrostatic discharge is the main reason for laser fault of the diode. Take effective precautions against ESD. When dealing with laser diodes, use wrist strap, grounding work surface and strict antistatic technology.

Electro-Optical Characteristics (T _{op} =25°C, CW mode)						
Parameters	Symbol	Min.	Typ.	Max.	Unit	Conditions
Optical Output Power	P _o	-	6	-	W	I _F =8.2A
Threshold Current	I _{th}	-	1	-	A	
Forward Current	I _F	-	8.2	-	A	
Slope Efficiency	η	-	0.83	-	W/A	P _o =6W
Power Conversion Efficiency	PCE	-	32	-	%	I _F =8.2A
Peak Wavelength	λ _p	930	940	950	nm	I _F =8.2A
Laser Forward Voltage	V _F	-	2.31	-	V	I _F =8.2A
Series Resistance	R _s	-	0.1	-	Ω	I _F =8.2A
Beam Divergence	FWHM _B	-	27	-	deg	
Wavelength Temperature Drift	Δλ _p / ΔT	-	-	0.07	nm/°C	I _F =8.2A

Note: Electro-optical characteristic with a package or diffuser would require further evaluation. Values are based on limited sample size and estimated values.

Typical Characteristics

LIV Graph

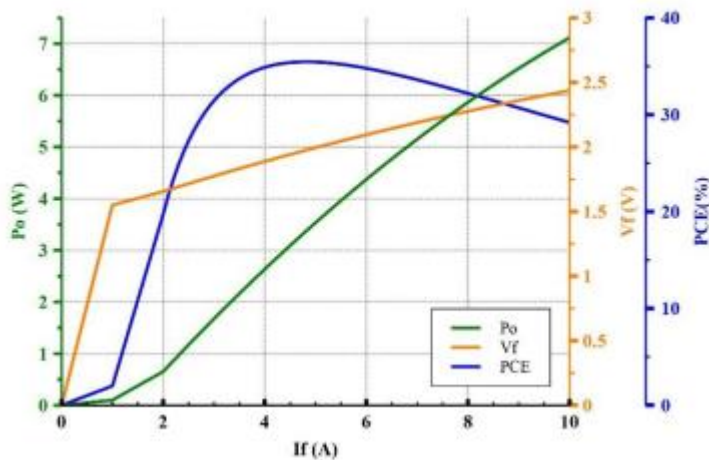

Intensity vs. Wavelength

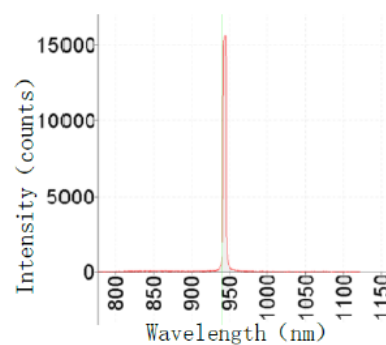

Outline Dimensions (unit: mm)

VCTMC-940C6WA (T-Mount SMD Package, Substrate Cu)

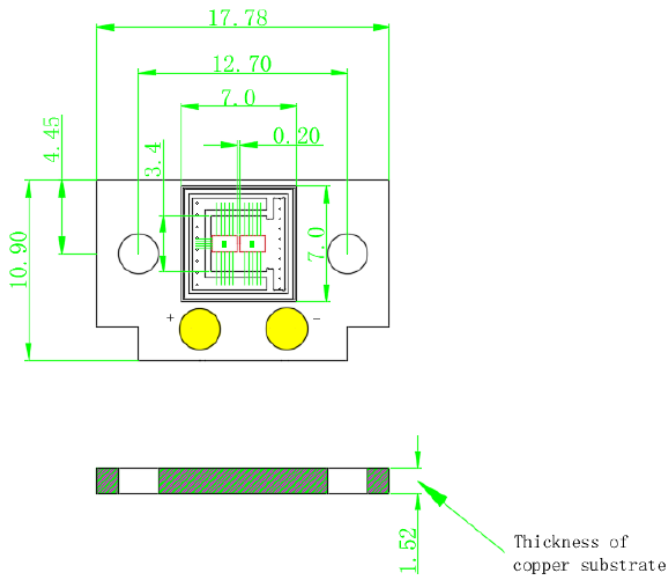

VC68A-940C6WA (6868 Package, Substrate AlN)

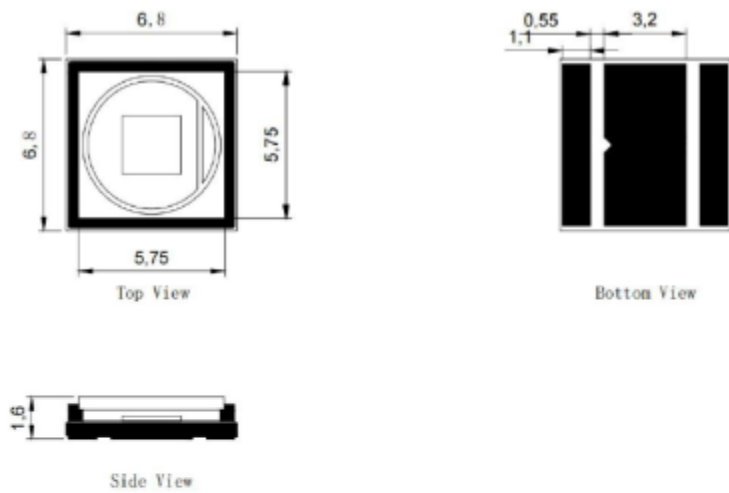

Electrical Internal Circuit



Recommend Solder Pad (mm)

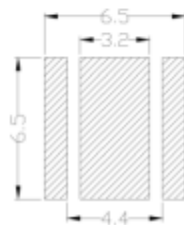

SMT Reflow Soldering Curve

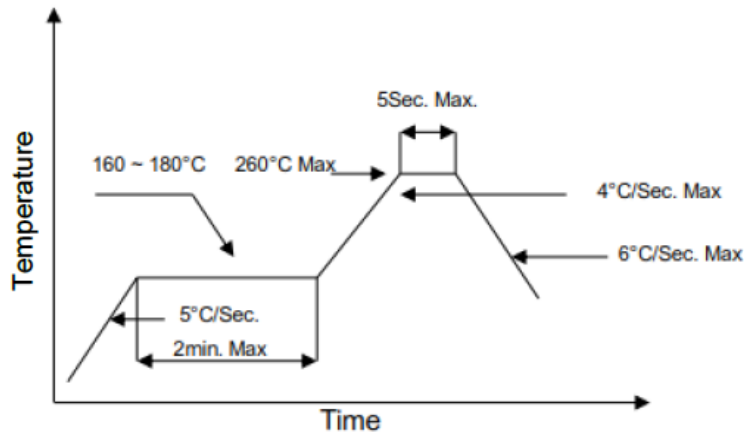

Note: Reflow soldering can be operated only one time. During the temperature ramp-up, no forces may be exerted on the LD which would deform or damage them. After soldering is completed, please do not process until the product temperature ramps down to room temperature.

Additional Notes

1. Please use solder paste to cure the laser diode.
2. Please make sure that the heat of VCSEL diode has been completely conducted to metal shell to avoid affecting the optical power output.
3. This VCSEL diode can be only used in constant voltage and current.
4. Please do not aim the laser at people or animals.
5. You may observe the laser spot through an image monitoring equipment.
6. Please do not touch VCSEL diode surface by naked hands or squeeze the sealant on VCSEL diode surface. It may cause wrong optical angle and distorted laser spot, and even damage the VCSEL diode.
7. Please use ceramic suction nozzle to absorb the VCSEL diode, so as to avoid VCSEL diode sticking to the nozzle.
8. Please add a 0.02s blowing action after locating the laser diode to aluminum substrate.
9. Specifications are subject to change without notice.



Lasermate Group, Inc.
 19608 Camino De Rosa
 Walnut, CA 91789 USA
 Tel: (909)718-0999
 Fax: (909)718-0998
sales@lasermate.com
www.lasermate.com