

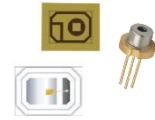

## 850nm 25W Pulsed VCSEL Diode

### VCx-850P25WA



#### Description

The Lasermate VCx-850P25WA is an 850nm wavelength, 25W output power, pulsed operating mode, Vertical Cavity Surface Emitting Laser (VCSEL) diode. Available in different package types, the VCSEL is characterized by its single wavelength, good thermal conduction, short rise time, high reliability, and easy collimation. Designed for 3D sensors, proximity sensor, 3D detection, scanning lidar, laser curtain, and range finder sensor applications.

#### Features

- 850nm VCSEL Diode
- Output power: 25W (ns pulse)
- Single wavelength
- Good thermal conduction
- Short rise time
- Oxide isolation technology
- High reliability
- Easy to collimate

#### Applications

- 3D sensors
- Proximity sensor
- 3D detection
- Scanning lidar
- Laser curtain
- Range finder sensor

#### Product Overview

The following table lists the available part numbers, as well as the package type of each of the part numbers.

Part Number	Package
VC20A-850P25WA	2016 Package, Substrate AlN
VC20C-850P25WA	2016 Package, Substrate CuAg
VCT5-850P25WA	TO56 Package, Substrate NiFe

## Specifications

Absolute Maximum Ratings				
Parameters	Symbol	Rating	Unit	Conditions
Case Operating Temperature	Top	-40 to 85	°C	
Storage Temperature	Tstg	-40 to 105	°C	
Reflow Soldering Temperature	Tsol	260°C	°C	10 seconds
Reverse Voltage	Vr	5	V	
Maximum Continuous Current	I <sub>max</sub>	90	A	Duty cycle 0.1% max
ESD Exposure (Human Body) Model	ESD	2K	V	

### Notes:

- Stresses greater than those listed under “Absolute Maximum Ratings” may cause permanent damage to the device. This is a stress rating only and functional operation of the device at these or other conditions above those indicated in the operations section for expanded periods of time may affect reliability.
- In its maximum rating diode laser operation could damage its performance or cause potential safety hazard such as equipment failure.
- Electrostatic discharge is the main reason for laser fault of the diode. Take effective precautions against ESD. When dealing with laser diodes, use wrist strap, grounding work surface and strict antistatic technology.

Electro-Optical Characteristics (T <sub>op</sub> =25°C, Pulse width 8.8ns at 11.68 kHz)						
Parameters	Symbol	Min.	Typ.	Max.	Unit	Conditions
Optical Output Power	P <sub>o</sub>	20	25	30	W	I <sub>F</sub> =81A
Threshold Current	I <sub>th</sub>	-	0.1	-	A	
Forward Pulse Current		-	81	-	A	
Emission Area		-	370x371	-	um	
Peak Wavelength	λ <sub>P</sub>	840	850	860	nm	P <sub>o</sub> =25W
Pulse Forward Voltage	V <sub>F</sub>	36	37	38	V	I <sub>F</sub> =81A
Series Resistance	R <sub>S</sub>	0.44	0.46	0.47	Ω	I <sub>F</sub> =81A
Beam Angle	Θ	-	20	-	Deg	I <sub>F</sub> =81A
Wavelength Temperature Drift	Δλ <sub>P</sub> / ΔT	-	0.07	-	nm/°C	I <sub>F</sub> =81A
Rise Time	Tr	-	2.8	-	ns	
Soldering Temperature	Tsol			260	°C	10 seconds
Duty Cycle		-	-	0.1	%	

Typical Characteristics

LIV Graph

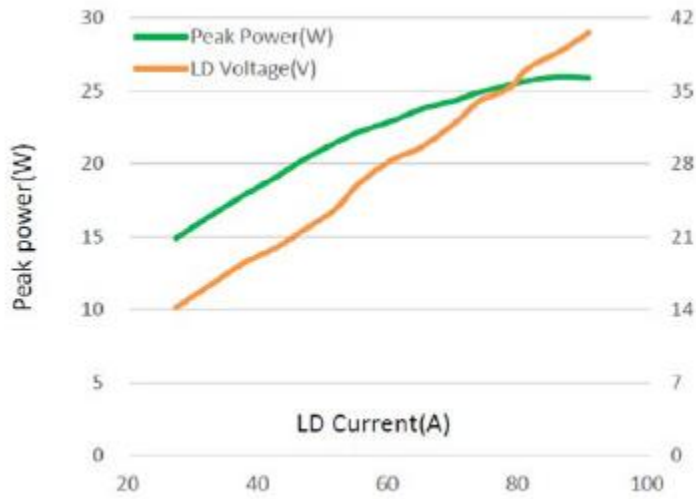

Pulse width=8.8ns

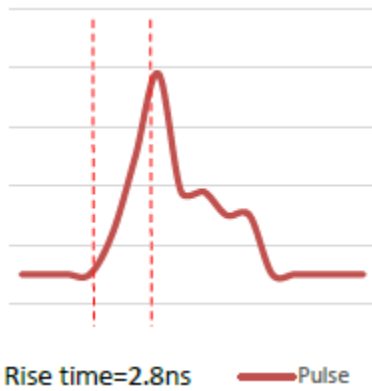

Intensity vs. Wavelength

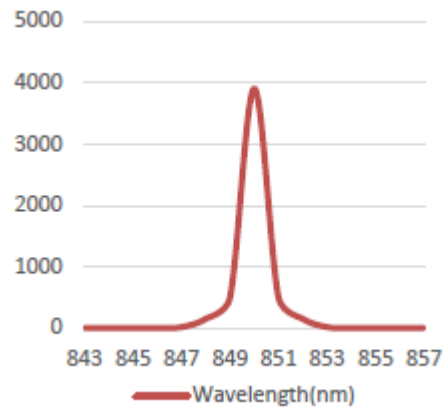

**Outline Dimensions (unit: mm)**

VC20A-850P25WA (2016 SMD Package, Substrate AlN)

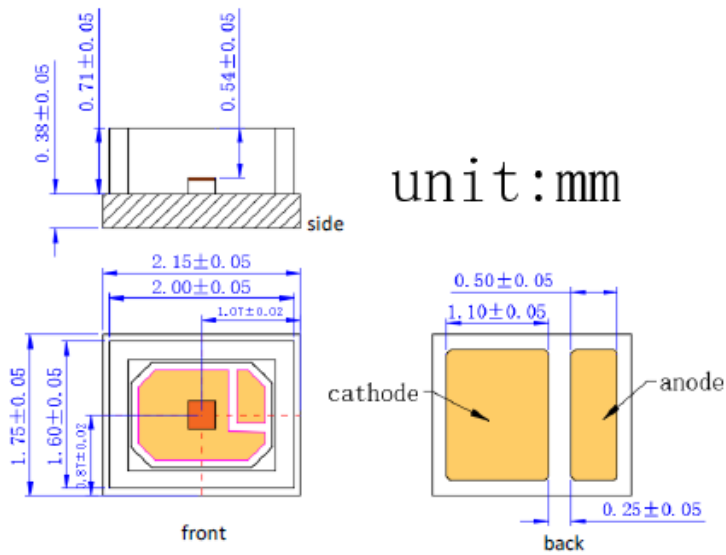

VC20C-850P25WA (2016 SMD Package, Substrate CuAg)

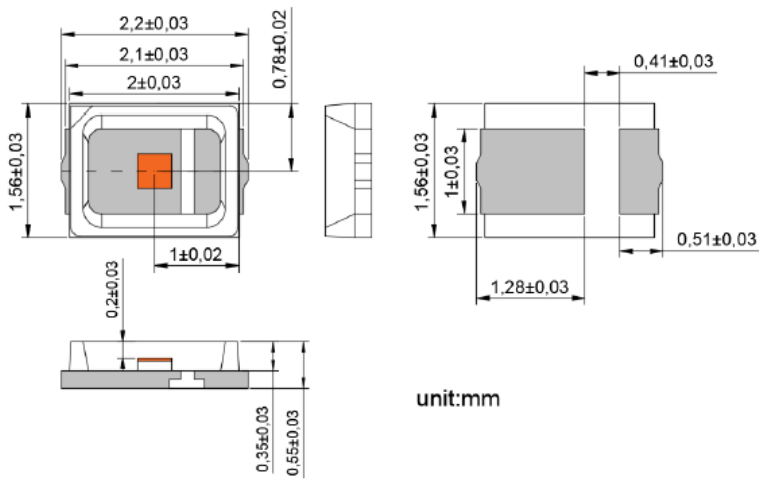

VCT5-850P25WA (TO-56 Package, Substrate NiFe)

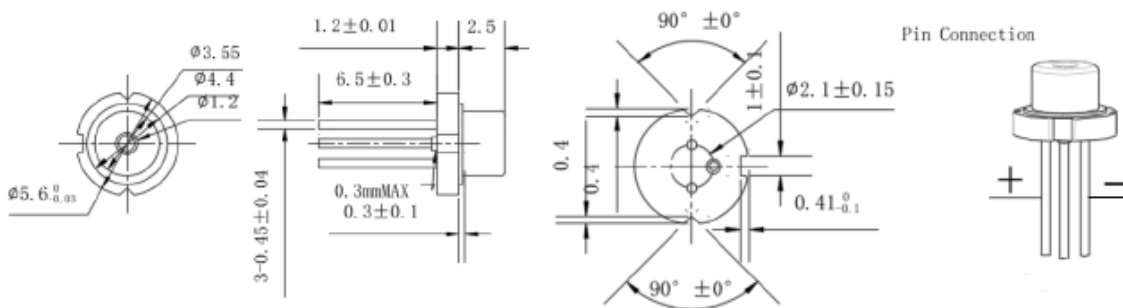

## SMT Reflow Soldering Curve

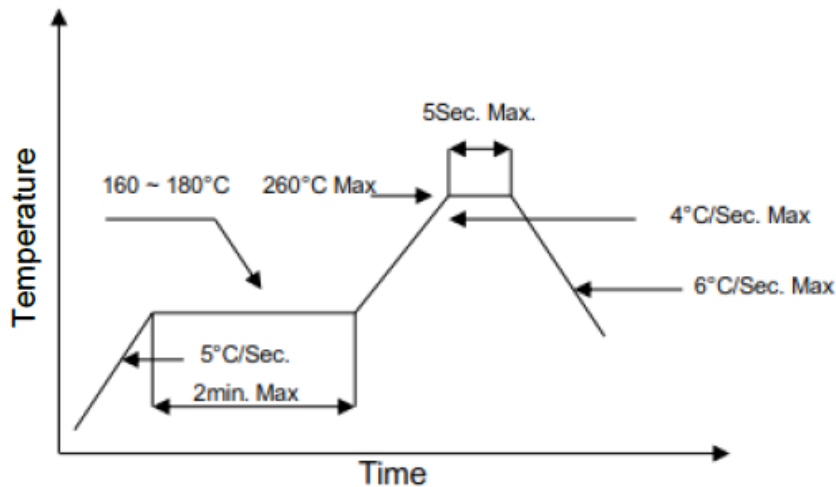

Note: Reflow soldering can be operated only one time. During the temperature ramp-up, no forces may be exerted on the LD which would deform or damage them. After soldering is completed, please do not process until the product temperature ramps down to room temperature.

### Additional Notes

1. Please use solder paste to cure the laser diode.
2. Please make sure that the heat of VCSEL diode has been completely conducted to metal shell to avoid affecting the optical power output.
3. This VCSEL diode can be only used in constant voltage and current.
4. Please do not aim the laser at people or animals.
5. You may observe the laser spot through an image monitoring equipment.
6. Please do not touch VCSEL diode surface by naked hands or squeeze the sealant on VCSEL diode surface. It may cause wrong optical angle and distorted laser spot, and even damage the VCSEL diode.
7. Please use ceramic suction nozzle to absorb the VCSEL diode, so as to avoid VCSEL diode sticking to the nozzle.
8. Please add a 0.02s blowing action after locating the laser diode to aluminum substrate.
9. Specifications are subject to change without notice.



**Lasermate Group, Inc.**  
 19608 Camino De Rosa  
 Walnut, CA 91789 USA  
 Tel: (909)718-0999  
 Fax: (909)718-0998  
[sales@lasermate.com](mailto:sales@lasermate.com)  
[www.lasermate.com](http://www.lasermate.com)