



850nm 20W Pulsed VCSEL Diode

VCx-850P20WA



Description

The Lasermate VCx-850P20WA is an 850nm wavelength, 20W output power, pulsed operating mode, Vertical Cavity Surface Emitting Laser (VCSEL) diode. Available in different package types, the VCSEL features single longitudinal mode, good thermal conduction, short rise time, and high reliability. Ideal for 3D sensor, Lidar, IR illumination, medical, proximity sensors.

Features

- 850nm VCSEL Diode
- Output power: 20W
- Single wavelength
- Good thermal conduction
- Short rise time
- Oxide isolation technology
- High reliability
- Easy to collimate

Applications

- 3D sensor
- Lidars
- IR illumination
- Proximity sensor
- Medical application

Product Overview

The following table lists the available part numbers, as well as the package type of each of the part numbers.

Part Number	Package
VC06A-850P20WA	0613 Package, Substrate AlN
VCTMC-850P20WA	T-Mount Package, Substrate Cu

Specifications

Absolute Maximum Ratings				
Parameters	Symbol	Rating	Unit	Conditions
Case Operating Temperature	Top	-40 to 85	°C	
Storage Temperature	Tstg	-40 to 105	°C	
Reflow Soldering Temperature	Tsol	260	°C	10 seconds
Reverse Voltage	Vr	15	V	
Maximum Continuous Current	I _{max}	8	A	
ESD Exposure (Human Body) Model	ESD	2k-4k (Class 2)	V	
ESD Exposure (Machine) Model	ESD	200-400 (Class B)	V	

Notes:

- Stresses greater than those listed under “Absolute Maximum Ratings” may cause permanent damage to the device. This is a stress rating only and functional operation of the device at these or other conditions above those indicated in the operations section for expanded periods of time may affect reliability.
- In its maximum rating diode laser operation could damage its performance or cause potential safety hazard such as equipment failure.
- Electrostatic discharge is the main reason for laser fault of the diode. Take effective precautions against ESD. When dealing with laser diodes, use wrist strap, grounding work surface and strict antistatic technology.

Electro-Optical Characteristics (T _{op} =25°C, Pulse width 100ms, Duty cycle 10%)							
Parameters	Symbol	Min.	Typ.	Max.	Unit	Conditions	
Optical Output Power	P _o	19	20	-	W	I _F =5A	
Threshold Current	I _{th}	-	1	-	A		
Forward Current	I _F	-	5	-	A		
Slope Efficiency	η	-	1.8	-	W/A		
Power Conversion Efficiency	PCE	-	31	-	%	I _F =5A	
Peak Wavelength	λ _P	840	850	860	nm	P _o =20W	
Laser Forward Voltage	V _F	-	12	-	V	I _F =5A	
Series Resistance	R _S	-	0.5	-	Ω	I _F =5A	
Beam Angle	(1/e ²)	θ	-	25	-	deg	I _F =5A
	FWHM	θ				deg	I _F =5A
Wavelength Temperature Drift	Δλ _P / ΔT	-	-	0.07	nm/°C	I _F =5A	
Emission Area			2.7x8.7		mm		
Illuminance Area			1x1.46		cm ²	At 15mm	
Soldering Temperature				260	°C	10 seconds	
Substrate			Cu				

Note: Electro-optical characteristic with a package or diffuser would require further evaluation. Values are based on limited sample size and estimated values.

Typical Characteristics

LIV Graph

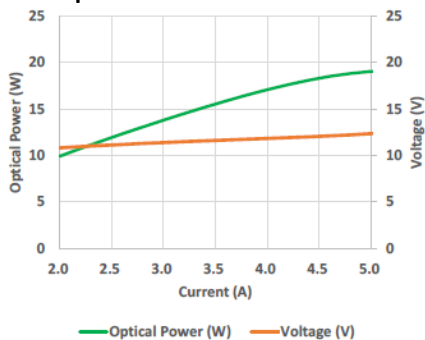

Intensity vs. Wavelength

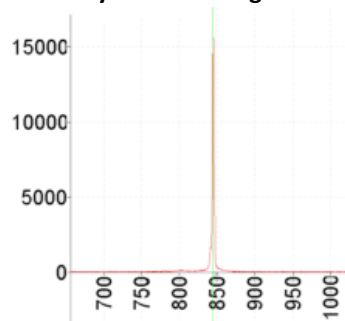

Outline Dimensions (unit: mm)

VC06A-850P20WA (0613 SMD Package, Substrate AlN)

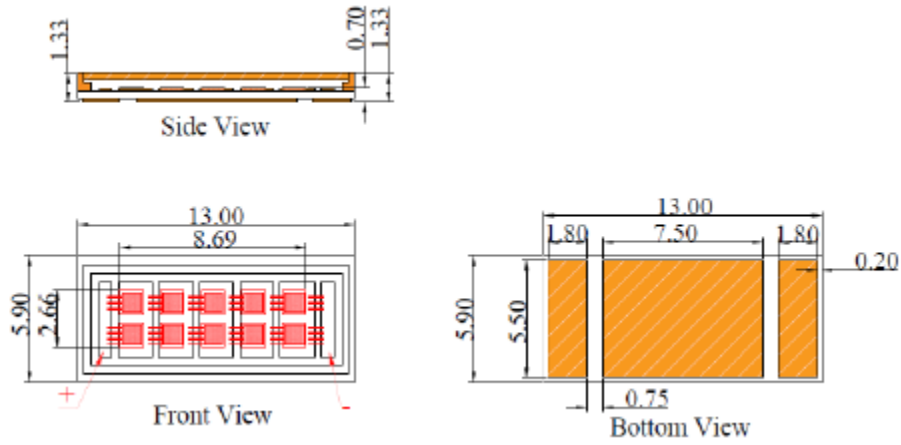

VCTMC-850P20WA (T-mount SMD Package, Substrate Cu)

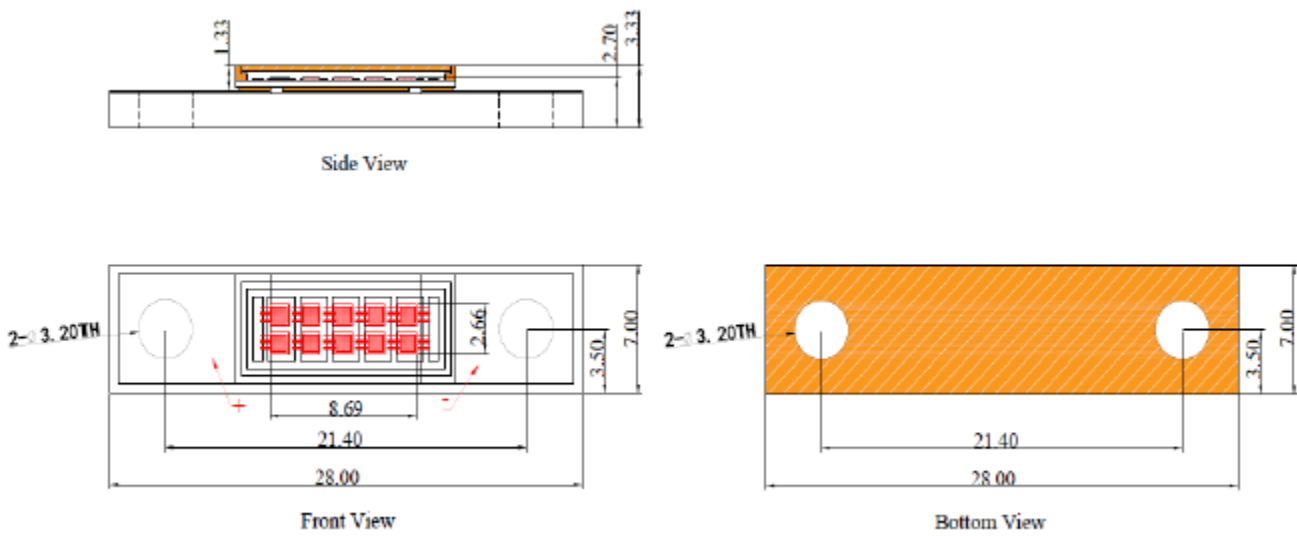

SMT Reflow Soldering Curve

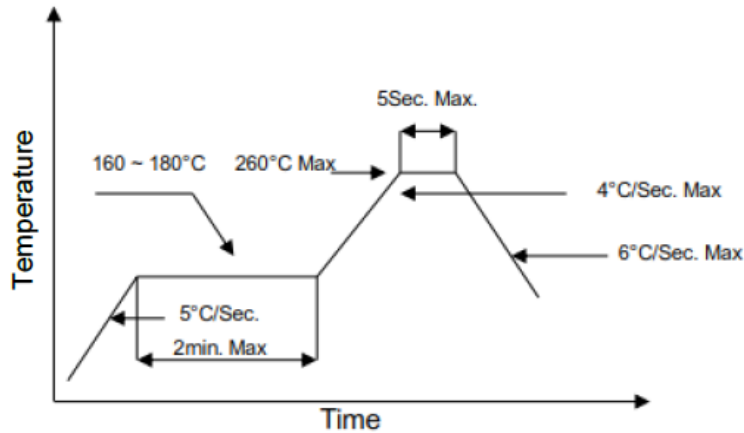

Note: Reflow soldering can be operated only one time. During the temperature ramp-up, no forces may be exerted on the LD which would deform or damage them. After soldering is completed, please do not process until the product temperature ramps down to room temperature.

Additional Notes

1. Please use solder paste to cure the laser diode.
2. Please make sure that the heat of VCSEL diode has been completely conducted to metal shell to avoid affecting the optical power output.
3. This VCSEL diode can be only used in constant voltage and current.
4. Please do not aim the laser at people or animals.
5. You may observe the laser spot through an image monitoring equipment.
6. Please do not touch VCSEL diode surface by naked hands or squeeze the sealant on VCSEL diode surface. It may cause wrong optical angle and distorted laser spot, and even damage the VCSEL diode.
7. Please use ceramic suction nozzle to absorb the VCSEL diode, so as to avoid VCSEL diode sticking to the nozzle.
8. Please add a 0.02s blowing action after locating the laser diode to aluminum substrate.
9. Specifications are subject to change without notice.



Lasermate Group, Inc.
 19608 Camino De Rosa
 Walnut, CA 91789 USA
 Tel: (909)718-0999
 Fax: (909)718-0998
sales@lasermate.com
www.lasermate.com