



1.25Gbps TX:1550nm DFB LD / RX:1310nm PIN WDM Bi-Directional Module Pigtail

T15D-R13-P-FCHCH



Description

The Lasermate T15D-R13-P-FCHCH is a 1550nm MQW-DFB LD, 1310nm PIN receiver, WDM Bi-directional module designed for use in communication applications.

Features

- Single Fiber with Bi-directional Transmission
- Integrated Wavelength Division Multiplexer
- 1550nm MQW-DFB LD
- 1310nm InGaAs PIN Receiver
- Uncooled
- Low threshold current
- Hermetically sealed
- Operating temperature -40 to +85°C

Packaging

- Package in pigtailed module with FC/PC

Applications

- Optical Communication System
- Gigabit Ethernet links
- Fiber Channel Link at 1.06Gbps

Specifications

Absolute Maximum Ratings					
Parameters		Symbol	Value	Unit	Conditions
Storage temperature		Tstg	-40~+85	°C	
Operating case temperature		Top	-40~+85	°C	
TX	Peak optical output power	Po	8	mW	
	Forward current (LD)	IfLD	150	mA	
	Reverse voltage (LD)	VrLD	2	V	
	Reverse current (PD)	IrPD	2	mA	
	Reverse voltage (PD)	VrPD	15	V	
RX	Reverse Voltage	Vr	10	V	
Soldering temperature		Stemp	260	°C	10 seconds

TX Electro-Optical Characteristics (CW @ T _c = 25°C unless otherwise noted)						
Parameters	Symbol	Min.	Typ.	Max.	Unit	Conditions
Threshold current	I _{th}	–	8	15	mA	CW
		–	–	50		CW, T _c = -40~85°C
Operating voltage	V _{op}	–	1.2	1.6	V	CW, Pop, T _c = -40~85°C
Operating power	Pop	1	–	–	mW	Pop = I _{th} +20mA
Peak wavelength	λ _p	1530	–	1570	nm	CW, Pop
Side-mode suppression rate	SMSR	30	–	–	dB	CW, Pop
Spectral Width (-20dB)	Δλ	–	–	1	nm	CW, Pop
Rise time	T _r	–	–	0.3	ns	I _b =I _{th} , 20%~80%, T _c =-40~85°C
Fall time	T _f	–	–	0.3	ns	I _b =I _{th} , 20%~80%, T _c =-40~85°C
Monitor current	I _m	0.1	0.5	–	mA	Pop, V _{rp} =5V
Monitor dark current	I _d	–	–	100	nA	V _{rp} = 5V
Monitor capacitance	C	–	–	10	pF	V _{rp} = 5V, f=1MHZ
Tracking error	TE	–	±0.7	±1.5	dB	APC, -40~85°C

RX Electro-Optical Characteristics (CW @ T _c = 25°C unless otherwise noted)						
Parameters	Symbol	Min.	Typ.	Max.	Unit	Conditions
Detection Range	λ	1260	–	1360	nm	
Saturation Power	P _{sat}	0	–	–	dBm	V _r =5V,λ=1310nm
Responsivity	R	0.65	–	–	A/W	V _r =5V,Pin=100uW
Dark Current	I _d	–	0.1	2.0	nA	V _r =5V
Capacitance	C	–	0.7	1.2	pF	V _r =5V
Bandwidth	BW	1.5	–	–	GHz	V _r =5V

Fiber Pigtail Specifications						
Parameters	Symbol	Min.	Typ.	Max.	Unit	
Fiber type	Single Mode Fiber (Flame Retardant Hytrel Coating)					
Cladding diameter	D _{cl}	122	125	128	um	
Mode field diameter	D _{mf}	-	10	-	um	
Coating diameter	D _{bc}	-	0.9	1	mm	
Pigtail length*	L	0.9	1.0	1.1	m	
Bending radius	R _b	30	-	-	mm	
Connector	FC/PC					
*From the ferrule-end to the bottom of TO-header.						

Outline Dimensions (unit: mm)

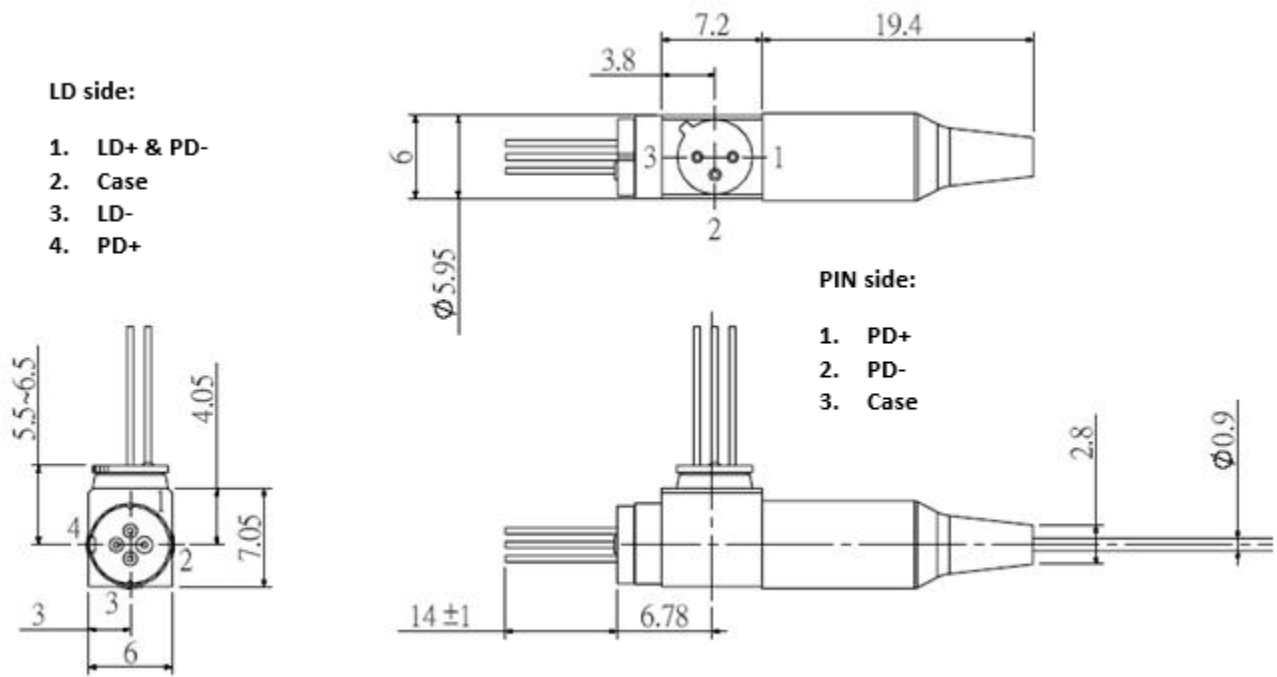

Additional Notes

- Avoid eye or skin exposure to laser radiations.
- The device is sensitive to electro-static discharge (ESD). The device should be handled with ESD proof tools. To assemble the device on PCB, proper grounding is required to prevent ESD.
- Specifications are subject to change without notice.



Lasermate Group, Inc.
 19608 Camino De Rosa
 Walnut, CA 91789 USA
 Tel: (909)718-0999
 Fax: (909)718-0998
sales@lasermate.com
www.lasermate.com