



## 2.5Gbps TX:1490nm/RX:1310nm SMF 60km BiDi SFP LC Optical Transceiver

### CS4T3-48H-3L-Tx-L



#### DESCRIPTION

The CS4T3-48H-3L-Tx-L bi-directional SFP (Small Form Pluggable) transceivers are designed for use in 2.5Gbps links up to 60km over a single strand single-mode fiber.

#### FEATURES

- Compliant with SFF8472 diagnostic monitoring interface
- Simplex LC connector
- Differential inputs and outputs
- Single power supply 3.3V
- Hot pluggable
- Class 1 laser product compliant with EN 60825-1
- Input/Output: AC/AC
- LOS: LVTTTL
- LD Type: 1490 DFB

#### APPLICATIONS

- Single-mode core fiber backbone links up to 60km
- 2500M / OC48 / STM-16

#### PRODUCT OVERVIEW

PART NUMBER	OPERATING TEMPERATURE
CS4T3-48H-3L-TC-L	0°C to 70°C
CS4T3-48H-3L-TI-L	-40°C to 85°C

## DIAGNOSTICS

PARAMETER	RANGE	ACCURACY	UNIT	CALIBRATION
Module Internal Temperature	-40 to 95	±3	°C	External
Module Internal Voltage	3.1 to 3.5	±0.1	V	
Bias Current	0 to 100	±10%	mA	
TX Power	-5 to +6	±3 dB	dBm	
RX Power	-23 to 0	±3 dB	dBm	

## ABSOLUTE MAXIMUM RATINGS

PARAMETER	SYMBOL	MIN	MAX	UNIT	NOTES
Storage Temperature	T <sub>S</sub>	-40	85	°C	
Supply Voltage	V <sub>CC</sub>	-0.5	4.0	V	
Input Voltage	V <sub>IN</sub>	-0.5	V <sub>CC</sub>	V	

## RECOMMENDED OPERATING CONDITIONS

PARAMETER	SYMBOL	MIN	MAX	UNIT	NOTES
Case Operating Temperature	T <sub>C</sub>	0	70	°C	CS4T3-48H-3L-TC-L
		-40	85		CS4T3-48H-3L-TI-L
Supply Voltage	V <sub>CC</sub>	3.1	3.5	V	
Supply Current	I <sub>TX</sub> + I <sub>RX</sub>	-	250	mA	

TRANSMITTER ELECTRO-OPTICAL CHARACTERISTICS (V<sub>CC</sub> = 3.1V to 3.5V, T<sub>C</sub> = 0°C to 70°C, -40°C to 85°C)

PARAMETER	SYMBOL	MIN	TYP.	MAX	UNIT	NOTES
Bit Rate	B	-	2488	-	Mbps	
Output Optical Power 9/125um fiber	P <sub>out</sub>	-2	-	+3	dBm	Average
Extinction Ratio	ER	6	-	-	dB	
Center Wavelength	λ <sub>C</sub>	1480	1490	1500	nm	
Spectral Width (-20dB)	Δλ	-	-	0.6	nm	
Side Mode Suppression Ratio	SMSR	30			dB	
Output Eye	Compliant with Telcordia GR-253-CORE Issue 3 and ITU-T recommendation G-957					
Max. P <sub>out</sub> TX-DISABLE Asserted	P <sub>OFF</sub>	-	-	-45	dBm	
Differential Input Voltage	V <sub>DIFF</sub>	0.4	-	2.0	V	

RECEIVER ELECTRO-OPTICAL CHARACTERISTICS (V<sub>CC</sub> = 3.1V to 3.5V, T<sub>C</sub> = 0°C to 70°C, -40°C to 85°C)

PARAMETER	SYMBOL	MIN	TYP.	MAX	UNIT	NOTES
Bit Rate	B	-	2488	-	Mbps	
Optical Input Power-Maximum	P <sub>IN</sub>	0	-	-	dBm	BER<10 <sup>-10</sup>
Optical Input Power-Minimum (Sensitivity)	P <sub>IN</sub>	-	-	-23	dBm	BER<10 <sup>-10</sup>
Operating Center Wavelength	λ <sub>C</sub>	1260	-	1360	nm	
Optical Return Loss	ORL	14	-	-	dB	λ=1260~1360nm
LOS Asserted	P <sub>A</sub>	-35	-	-	dBm	
LOS Deasserted	P <sub>D</sub>	-	-	-23	dBm	
Differential Output Voltage	V <sub>DIFF</sub>	0.5	-	1.2	V	
Receiver Loss of Signal Output Voltage-Low	RX_LOS <sub>L</sub>	0	-	0.5	V	
Receiver Loss of Signal Output Voltage-High	RX_LOS <sub>H</sub>	2.4	-	V <sub>CC</sub>	V	

**DIMENSIONS**

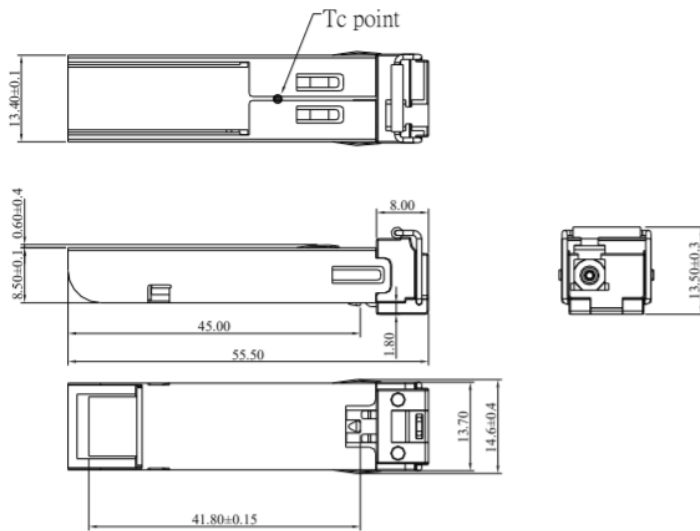

**DIMENSIONS ARE IN MILLIMETERS**

**ALL DIMENSIONS ARE ±0.2mm UNLESS OTHERWISE SPECIFIED**

**SFP HOST BOARD MECHANICAL LAYOUT**

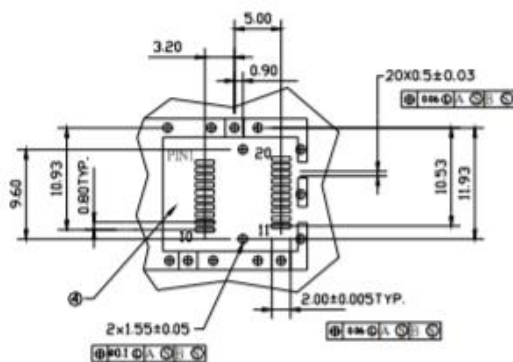
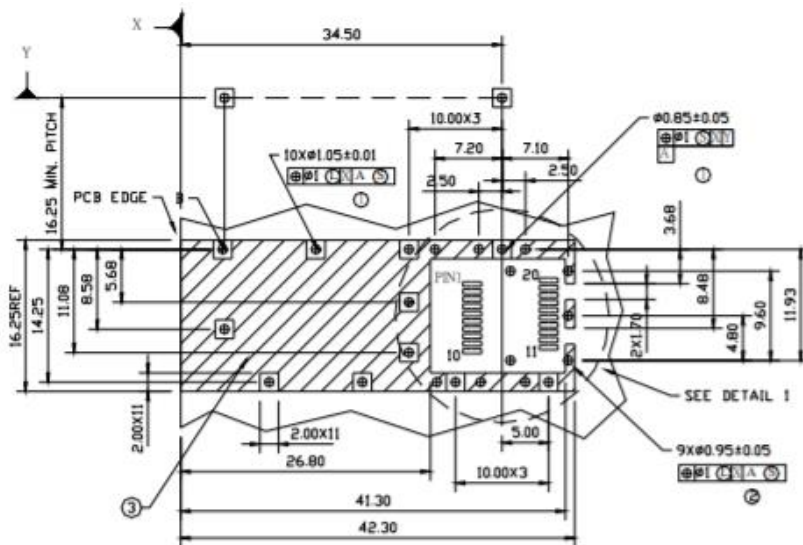

DETAIL 1

**LEGEND**

- 1.PADS AND VIAS ARE CHASSIS GROUND
- 2.THROUGH HOLES, PLATING OPTIONAL
- 3.HATCHED AREA DENOTES COMPONENT AND TRACE KEEPOUT(EXCEPT CHASSIS GROUND)
- 4.AREA DENOTES COMPONENT KEEPOUT (TRACES ALLOWED)

**DIMENSIONS ARE IN MILLIMETERS**

## PIN ASSIGNMENT

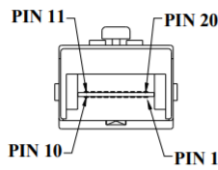

Pin	Signal Name	Description
1	$T_{GND}$	Transmit Ground
2	$TX\_FAULT$	Transmit Fault
3	$TX\_DISABLE$	Transmit Disable
4	$MOD\_DEF (2)$	SDA Serial Data Signal
5	$MOD\_DEF (1)$	SCL Serial Clock Signal
6	$MOD\_DEF (0)$	TTL Low
7	$RATE\_SELECT$	Open Circuit
8	$RX\_LOS$	Receiver Loss of Signal, TTL High, open collector
9	$R_{GND}$	Receiver Ground
10	$R_{GND}$	Receiver Ground
11	$R_{GND}$	Receiver Ground
12	$RX-$	Receive Data Bar, Differential PECL, ac coupled
13	$RX+$	Receive Data, Differential PECL, ac coupled
14	$R_{GND}$	Receiver Ground
15	$V_{CCR}$	Receiver Power Supply
16	$V_{CCT}$	Transmitter Power Supply
17	$T_{GND}$	Transmitter Ground
18	$TX+$	Transmit Data, Differential PECL, ac coupled
19	$TX-$	Transmit Data Bar, Differential PECL, ac coupled
20	$T_{GND}$	Transmitter Ground

## EYE SAFETY MARK

The single-mode transceiver is a class 1 laser product. It complies with EN 60825-1 and FDA 21 CFR 1040.10 and 1040.11. In order to meet laser safety requirements, the transceiver shall be operated within the Absolute Maximum Ratings.

## Required Mark

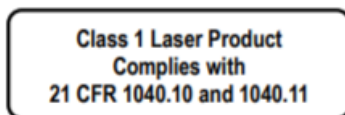

**[Caution]** All adjustments have been done at the factory before the shipment of the devices. No maintenance and user serviceable part is required. Tampering with and modifying the performance of the device will result in voided product warranty.

**ADDITIONAL NOTES**

- Avoid eye or skin exposure to laser radiations.
- The device is sensitive to electro-static discharge (ESD). The device should be handled with ESD proof tools. To assemble the device on PCB, proper grounding is required to prevent ESD.
- Specifications are subject to change without notice.



**Lasermate Group, Inc.**  
19608 Camino De Rosa  
Walnut, CA 91789 USA  
Tel: (909)718-0999  
Fax: (909)718-0998  
[sales@lasermate.com](mailto:sales@lasermate.com)  
[www.lasermate.com](http://www.lasermate.com)