



1.25Gbps TX:1490nm/RX:1310nm SMF 40km BiDi SFP LC Optical Transceiver

CS4T3-24H-3L-Tx-L



DESCRIPTION

The CS4T3-24H-3L-Tx-L bi-directional SFP (Small Form Pluggable) transceivers are designed for use in 1.25Gbps links up to 40km over a single strand single-mode fiber.

FEATURES

- RoHS Compliant
- Compliant with IEEE802.3ah 1000BASE-BX application
- Compliant with SFF8472 Digital Diagnostic Standard
- Industry standard small form pluggable (SFP) package
- Hot pluggable
- Class 1 laser product compliant with EN 60825-1
- LD Type: 1490 DFB

APPLICATIONS

- Single-mode core fiber backbone links up to 40km
- 1000Base-BX

PRODUCT OVERVIEW

PART NUMBER	OPERATING TEMPERATURE
CS4T3-24H-3L-TC-L	0°C to 70°C
CS4T3-24H-3L-TI-L	-40°C to 85°C

DIAGNOSTICS

PARAMETER	RANGE	ACCURACY	UNIT	CALIBRATION
Temperature	-40 to 95	±3	°C	External
Voltage	3.0 to 3.6	±0.1	V	
Bias Current	0 to 100	±10%	mA	
TX Power	-6 to +5	±3 dB	dBm	
RX Power	-23 to -3	±3 dB	dBm	

ABSOLUTE MAXIMUM RATINGS

PARAMETER	SYMBOL	MIN	MAX	UNIT	NOTES
Storage Temperature	T _S	-40	85	°C	
Supply Voltage	V _{CC}	-0.5	4.0	V	
Input Voltage	V _{IN}	-0.5	V _{CC}	V	

RECOMMENDED OPERATING CONDITIONS

PARAMETER	SYMBOL	MIN	MAX	UNIT	NOTES
Case Operating Temperature	T _C	0	70	°C	CS4T3-24H-3L-TC-L
		-40	85		CS4T3-24H-3L-TI-L
Supply Voltage	V _{CC}	3.1	3.5	V	
Supply Current	I _{TX} + I _{RX}	-	300	mA	
Relative Humidity (Non-condensing)	RH	5	95	%	

TRANSMITTER ELECTRO-OPTICAL CHARACTERISTICS (V_{CC} = 3.1V to 3.5V, T_C = 0°C to 70°C, -40°C to 85°C)

PARAMETER	SYMBOL	MIN	TYP.	MAX	UNIT	NOTES
Output Optical Power 9/125um fiber	P _{out}	-3	-	+2	dBm	Average
Extinction Ratio	ER	7	-	-	dB	
Center Wavelength	λ _C	1480	-	1500	nm	
Spectral Width (-20dB)	Δλ			0.88	nm	
Rise/Fall Time (20%~80%)	T _{r, f}	-	-	260	ps	
Relative Intensity Noise	RIN	-	-	-120	dB/Hz	
Total Jitter	TJ	-	-	227	ps	
Output Eye	Compliant with IEEE802.3z					
Max. P _{out} TX-DISABLE Asserted	P _{OFF}	-	-	-45	dBm	
Differential Input Voltage	V _{DIFF}	0.4	-	2.0	V	
Transmit Fault Output-Low	TX_FAULT _L	0.0	-	0.5	V	
Transmit Fault Output-High	TX_FAULT _H	2.4	-	V _{CC}	V	
Time to initialize, include reset of TX_FAULT	t _{init}	-	-	300	ms	
TX_FAULT from fault to assertion	t _{fault}	-	-	100	us	
TX_DISABLE time to start reset	t _{reset}	10	-	-	us	

RECEIVER ELECTRO-OPTICAL CHARACTERISTICS ($V_{CC} = 3.1V$ to $3.5V$, $T_c = 0^{\circ}C$ to $70^{\circ}C$, $-40^{\circ}C$ to $85^{\circ}C$)

PARAMETER	SYMBOL	MIN	TYP.	MAX	UNIT	NOTES
Optical Input Power-Maximum	P_{IN}	0	-	-	dBm	PRBS7, BER10^{-12}
RX Sensitivity	P_{IN}	-	-	-23	dBm	PRBS7, BER10^{-12}
Operating Center Wavelength	λ_c	1260	-	1360	nm	
Optical Return Loss	ORL	14	-	-	dB	$\lambda=1260\sim 1360nm$
Optical Isolation	ISO	-	-	-45	dB	$\lambda=1480\sim 1500nm$
LOS Deasserted	P_D	-	-	-23	dBm	
LOS Asserted	P_A	-35	-	-	dBm	
Differential Output Voltage	V_{DIFF}	0.5	-	1.2	V	
Data Output Rise, Fall Time (20%~80%)	$T_{r,f}$	-	-	0.35	ns	
Receiver Loss of Signal Output Voltage-Low	RX_LOSL	0	-	0.5	V	
Receiver Loss of Signal Output Voltage-High	RX_LOSH	2.4	-	V_{CC}	V	

DIMENSIONS

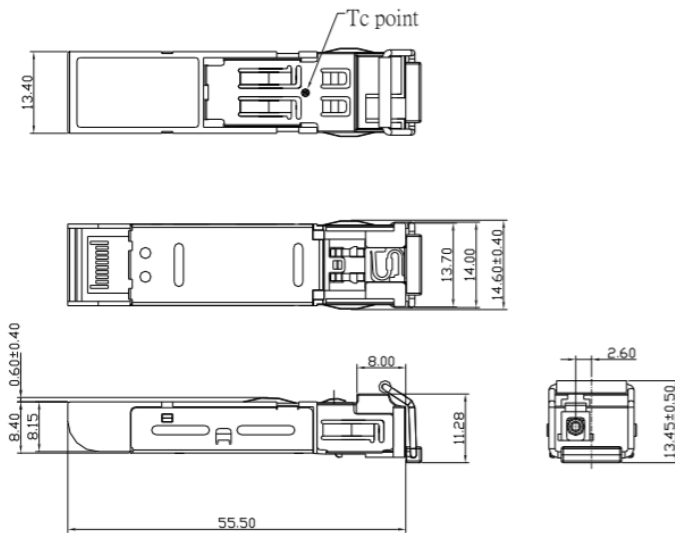

DIMENSIONS ARE IN MILLIMETERS

ALL DIMENSIONS ARE $\pm 0.2mm$ UNLESS OTHERWISE SPECIFIED

SFP HOST BOARD MECHANICAL LAYOUT

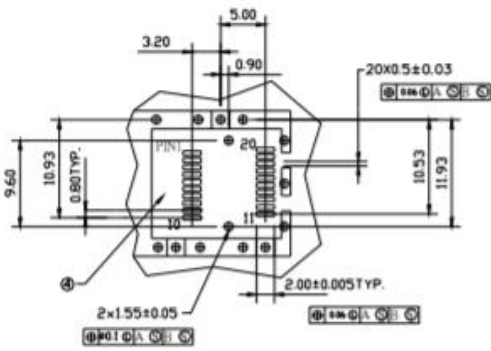
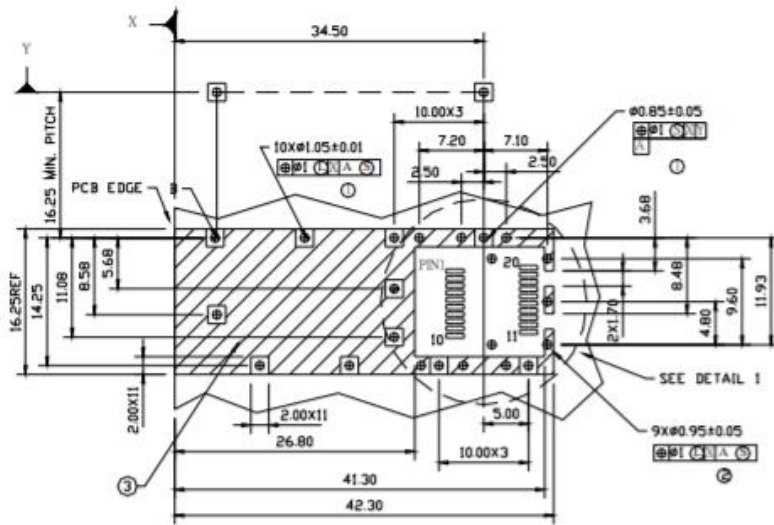

DETAIL 1

LEGEND

1. PADS AND VIAS ARE CHASSIS GROUND
2. THROUGH HOLES, PLATING OPTIONAL
3. HATCHED AREA DENOTES COMPONENT AND TRACE KEEPOUT (EXCEPT CHASSIS GROUND)
4. AREA DENOTES COMPONENT KEEPOUT (TRACES ALLOWED)

DIMENSIONS ARE IN MILLIMETERS

ASSEMBLY DRAWING (unit: mm)

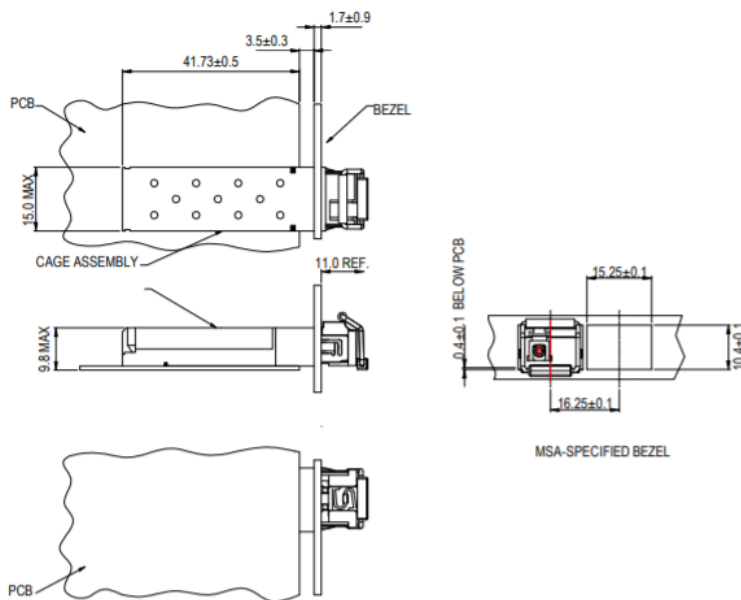

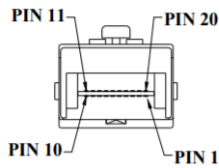
PIN ASSIGNMENT

Pin	Signal Name	Description
1	T_{GND}	Transmit Ground
2	TX_FAULT	Transmit Fault
3	$TX_DISABLE$	Transmit Disable
4	$MOD_DEF (2)$	SDA Serial Data Signal
5	$MOD_DEF (1)$	SCL Serial Clock Signal
6	$MOD_DEF (0)$	TTL Low
7	$RATE_SELECT$	Open Circuit
8	RX_LOS	Receiver Loss of Signal, TTL High, open collector
9	R_{GND}	Receiver Ground
10	R_{GND}	Receiver Ground
11	R_{GND}	Receiver Ground
12	$RX-$	Receive Data Bar, Differential , ac coupled
13	$RX+$	Receive Data, Differential , ac coupled
14	R_{GND}	Receiver Ground
15	V_{CCR}	Receiver Power Supply
16	V_{CCT}	Transmitter Power Supply
17	T_{GND}	Transmitter Ground
18	$TX+$	Transmit Data, Differential , ac coupled
19	$TX-$	Transmit Data Bar, Differential , ac coupled
20	T_{GND}	Transmitter Ground

ADDITIONAL NOTES

- Avoid eye or skin exposure to laser radiations.
- The device is sensitive to electro-static discharge (ESD). The device should be handled with ESD proof tools. To assemble the device on PCB, proper grounding is required to prevent ESD.
- Specifications are subject to change without notice.



Lasermate Group, Inc.
 19608 Camino De Rosa
 Walnut, CA 91789 USA
 Tel: (909)718-0999
 Fax: (909)718-0998
sales@lasermate.com
www.lasermate.com