



1.25Gbps TX:1310nm/RX:1550nm SMF 60km BiDi SFP LC Optical Transceiver

CS3T5-24H-3U-Tx-L



DESCRIPTION

The CS3T5-24H-3U-Tx-L bi-directional SFP (Small Form Pluggable) transceivers are designed for use in 1.25Gbps links up to 60km over a single strand single-mode fiber.

FEATURES

- Compliant with IEEE802.3z Gigabit Ethernet Standard
- Compliant with Fiber Channel 100-SM-LC-L standard
- Multi rate 125Mbps to 1.25Gbps
- Industry standard small form pluggable (SFP) package
- Simplex LC connector
- Single power supply 3.3V
- Differential LVPECL inputs and outputs
- TTL signal detect indicator
- Hot pluggable
- Class 1 laser product compliant with EN 60825-1
- LD Type: 1310 DFB

APPLICATIONS

- Single-mode core fiber backbone links up to 60km
- 1000Base Bidi

PRODUCT OVERVIEW

PART NUMBER	OPERATING TEMPERATURE
CS3T5-24H-3U-TC-L	0°C to 70°C
CS3T5-24H-3U-TI-L	-40°C to 85°C

DIAGNOSTICS

PARAMETER	RANGE	ACCURACY	UNIT	CALIBRATION
Temperature	-40 to 95	±3	°C	External
Voltage	0 to V _{CC}	±0.1	V	
Bias Current	0 to 120	±5	mA	
TX Power	-3 to +7	±3 dB	dBm	
RX Power	-23 to -3	±3 dB	dBm	

ABSOLUTE MAXIMUM RATINGS

PARAMETER	SYMBOL	MIN	MAX	UNIT	NOTES
Storage Temperature	T _S	-40	85	°C	
Supply Voltage	V _{CC}	-0.5	4.0	V	
Input Voltage	V _{IN}	-0.5	V _{CC}	V	
Output Current	I _o	-	50	mA	
Operating Current	I _{OP}	-	400	mA	

RECOMMENDED OPERATING CONDITIONS

PARAMETER	SYMBOL	MIN	MAX	UNIT	NOTES
Case Operating Temperature	T _C	0	70	°C	CS3T5-24H-3U-TC-L
		-40	85		CS3T5-24H-3U-TI-L
Supply Voltage	V _{CC}	3.1	3.5	V	
Supply Current	I _{TX} + I _{RX}		300	mA	

TRANSMITTER ELECTRO-OPTICAL CHARACTERISTICS (V_{CC} = 3.1V to 3.5V, T_C = 0°C to 70°C, -40°C to 85°C)

PARAMETER	SYMBOL	MIN	TYP.	MAX	UNIT	NOTES
Output Optical Power 9/125um fiber	P _{out}	0	-	+5	dBm	Average
Extinction Ratio	ER	9	-	-	dB	
Center Wavelength	λ _c	1290	1310	1330	nm	
Spectral Width (-20dB)	Δλ	-	-	1	nm	
Side Mode Suppression Ratio	SMSR	30			dB	
Rise/Fall Time (20%~80%)	T _{r, f}	-	-	260	ps	
Relative Intensity Noise	RIN	-	-	-120	dB/Hz	
Total Jitter	TJ	-	-	227	ps	
Output Eye	Compliant with IEEE802.3z					
Max. P _{out} TX-DISABLE Asserted	P _{OFF}	-	-	-45	dBm	
Differential Input Voltage	V _{DIFF}	0.4	-	2.0	V	
Transmit Fault Output-Low	TX_FAULT _L	0.0	-	0.5	V	
Transmit Fault Output-High	TX_FAULT _H	2.4	-	V _{CC}	V	
Time to initialize, include reset of TX_FAULT	t _{init}	-	-	300	ms	
TX_FAULT from fault to assertion	t _{fault}	-	-	100	us	
TX_DISABLE time to start reset	t _{reset}	10	-	-	us	

RECEIVER ELECTRO-OPTICAL CHARACTERISTICS ($V_{CC} = 3.1V$ to $3.5V$, $T_c = 0^{\circ}C$ to $70^{\circ}C$, $-40^{\circ}C$ to $85^{\circ}C$)

PARAMETER	SYMBOL	MIN	TYP.	MAX	UNIT	NOTES
Optical Input Power-Maximum	P_{IN}	-1	-	-	dBm	BER< 10^{-12}
RX Sensitivity @GbE	P_{IN}	-	-	-24	dBm	PRBS7, BER< 10^{-12}
RX Sensitivity @1x FC	P_{IN}	-	-	-24	dBm	PRBS7, BER< 10^{-12}
RX Sensitivity @OC-12	P_{IN}	-	-	-24	dBm	PRBS23, BER< 10^{-10}
RX Sensitivity @OC-3	P_{IN}	-	-	-24	dBm	PRBS23, BER< 10^{-10}
RX Sensitivity @125Mbps	P_{IN}	-	-	-24	dBm	PRBS7, BER< 10^{-10}
Operating Center Wavelength	λ_c	1480	-	1580	nm	
Optical Return Loss	ORL	14	-	-	dB	$\lambda=1480\sim 1580nm$
Optical Isolation	ISO	-	-	-45	dB	$\lambda=1260\sim 1360nm$
Signal Detect-Asserted	P_A	-	-	-24	dBm	
Signal Detect-Deasserted	P_D	-35	-	-	dBm	
Differential Output Voltage	V_{DIFF}	0.5	-	1.2	V	
Data Output Rise, Fall Time (20%~80%)	$T_{r,f}$	-	-	0.35	ns	
Receiver Loss of Signal Output Voltage-Low	RX_LOSL	0	-	0.5	V	
Receiver Loss of Signal Output Voltage-High	RX_LOSH	2.4	-	V_{CC}	V	

BLOCK DIAGRAM OF TRANSCEIVER

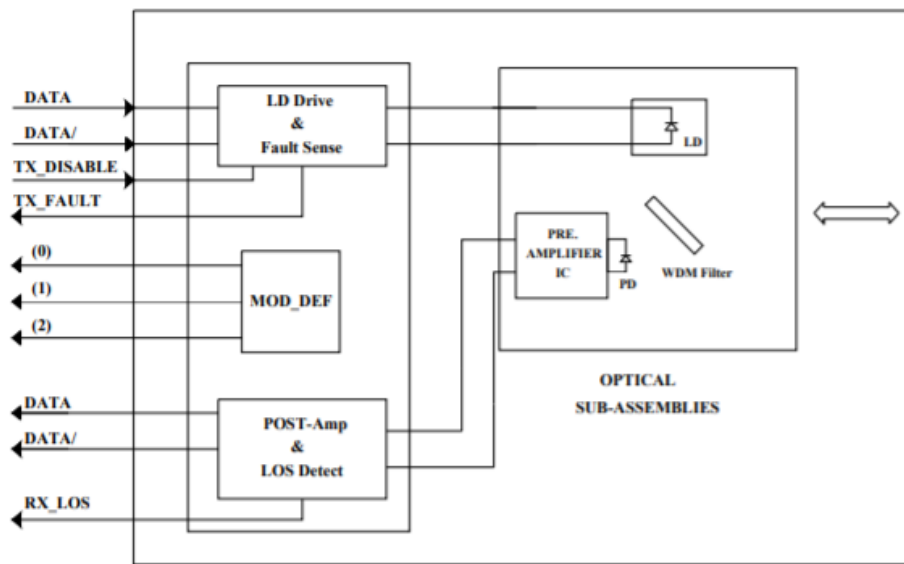

Transmitter and Receiver Optical Sub-Assembly Section - A 1310 nm InGaAsP laser and an InGaAs PIN photodiode integrate with an WDM filter to form a bi-directional single fiber optical subassembly (OSA). The laser of OSA is driven by a LD driver IC which converts differential input LVPECL logic signals into an analog laser driving current. The photodiode of OSA is connected to a circuit providing post-amplification quantization, and optical signal detection.

TX_FAULT - When sensing an improper power level in the laser driver, the SFP set this signal high and turns off the Laser. TX_FAULT can be reset with the TX_DISABLE line. The signal is in TTL level.

TX_DISABLE - The TX_DISABLE signal is high (TTL logic "1") to turn off the laser output.

Receive Loss (RX_LOS) - The RX_LOS is high (logic "1") when there is no incoming light from the companion transceiver. This signal is normally used by the system for the diagnostic purpose. The signal is operated in TTL level.

DIMENSIONS

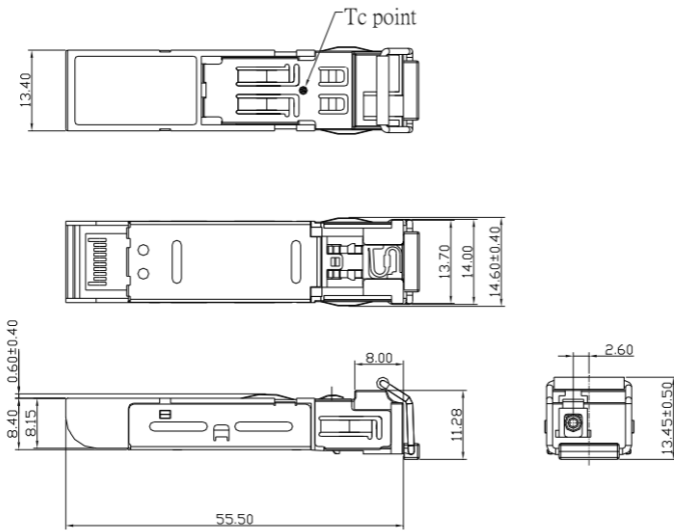

DIMENSIONS ARE IN MILLIMETERS

ALL DIMENSIONS ARE ± 0.2mm UNLESS OTHERWISE SPECIFIED

SFP HOST BOARD MECHANICAL LAYOUT

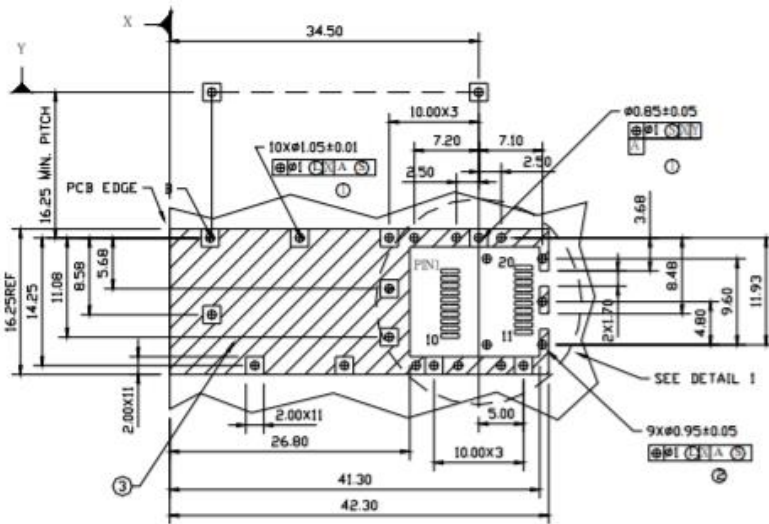

LEGEND

- 1.PADS AND VIAS ARE CHASSIS GROUND
- 2.THROUGH HOLES, PLATING OPTIONAL
- 3.HATCHED AREA DENOTES COMPONENT AND TRACE KEEPOUT(EXCEPT CHASSIS GROUND)
- 4.AREA DENOTES COMPONENT KEEPOUT (TRACES ALLOWED)

DIMENSIONS ARE IN MILLIMETERS

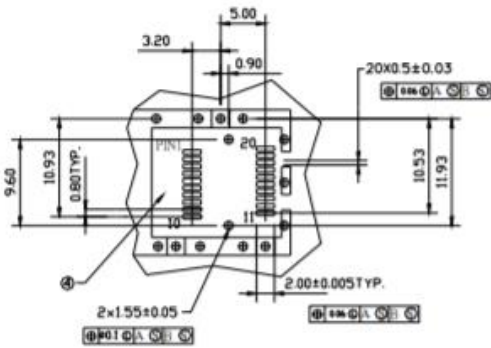

DETAIL I

ASSEMBLY DRAWING (unit: mm)

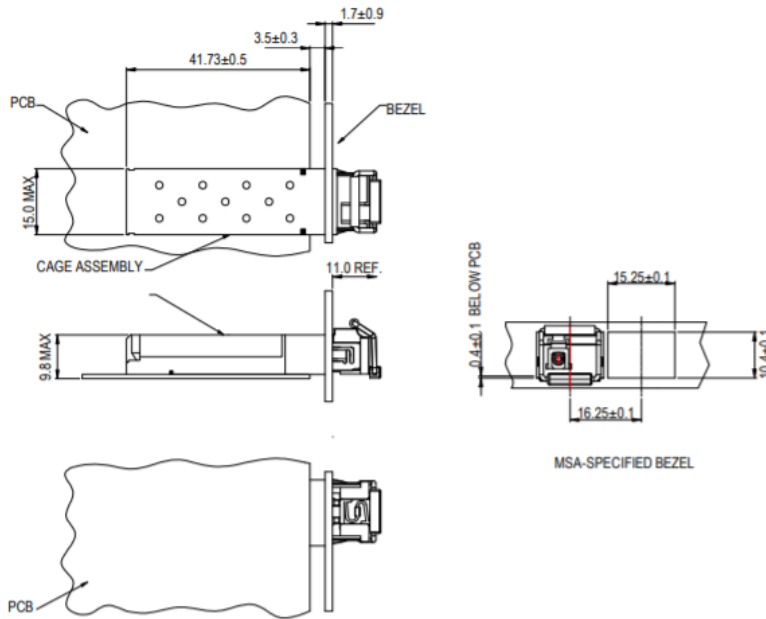

PIN ASSIGNMENT

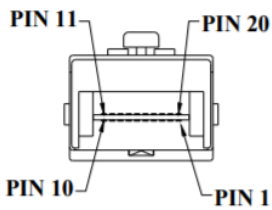

Pin	Signal Name	Description
1	T_{GND}	Transmit Ground
2	TX_FAULT	Transmit Fault
3	$TX_DISABLE$	Transmit Disable
4	$MOD_DEF (2)$	SDA Serial Data Signal
5	$MOD_DEF (1)$	SCL Serial Clock Signal
6	$MOD_DEF (0)$	TTL Low
7	$RATE_SELECT$	Open Circuit
8	RX_LOS	Receiver Loss of Signal, TTL High, open collector
9	R_{GND}	Receiver Ground
10	R_{GND}	Receiver Ground
11	R_{GND}	Receiver Ground
12	$RX-$	Receive Data Bar, Differential PECL, ac coupled
13	$RX+$	Receive Data, Differential PECL, ac coupled
14	R_{GND}	Receiver Ground
15	V_{CCR}	Receiver Power Supply
16	V_{CCT}	Transmitter Power Supply
17	T_{GND}	Transmitter Ground
18	$TX+$	Transmit Data, Differential PECL, ac coupled
19	$TX-$	Transmit Data Bar, Differential PECL, ac coupled
20	T_{GND}	Transmitter Ground

EYE SAFETY MARK

The single-mode transceiver is a class 1 laser product. It complies with EN 60825-1 and FDA 21 CFR 1040.10 and 1040.11. In order to meet laser safety requirements, the transceiver shall be operated within the Absolute Maximum Ratings.

Required Mark

Class 1 Laser Product
Complies with
21 CFR 1040.10 and 1040.11

[Caution] All adjustments have been done at the factory before the shipment of the devices. No maintenance and user serviceable part is required. Tampering with and modifying the performance of the device will result in voided product warranty.

ADDITIONAL NOTES

- Avoid eye or skin exposure to laser radiations.
- The device is sensitive to electro-static discharge (ESD). The device should be handled with ESD proof tools. To assemble the device on PCB, proper grounding is required to prevent ESD.
- Specifications are subject to change without notice.



Lasermate Group, Inc.
19608 Camino De Rosa
Walnut, CA 91789 USA
Tel: (909)718-0999
Fax: (909)718-0998
sales@lasermate.com
www.lasermate.com