

155Mbps 1470nm~1610nm SMF 35dB CWDM SFP Optical Transceiver with Duplex LC Connector

CS15xxD-03F-3U-TC-LD

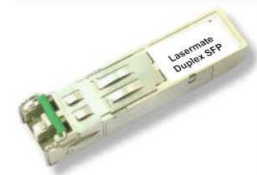

DESCRIPTION

The CS15xxD-03F-3U-TC-LD duplex SFP (Small Form Pluggable) optical transceivers are high performance, cost effective optical transceiver modules support data rates up to 155 Mb/s. They provide 35dB power budget over single mode fiber. There are eight center wavelengths available from 1470nm to 1610nm with 20nm channel spacing.

FEATURES

- RoHS compliant
- Compliant with SONET/SDH application
- Compliant with Fast Ethernet standard
- Compliant with SFF8472 diagnostic monitoring interface
- Industry standard small form pluggable (SFP) package
- Hot pluggable
- Single power supply 3.3V
- Duplex LC connector
- Differential LVPECL inputs and outputs
- TTL signal detect indicator
- Class 1 laser product compliant with EN 60825-1
- Input/Output: AC/AC
- Temperature: 0°C to 70°C
- 35dB power budget

APPLICATIONS

- CWDM Network

PRODUCT OVERVIEW

PART NUMBER	WAVELENGTH	OPERATING TEMPERATURE
CS1547D-03F-3U-TC-LD	1470nm	0°C to 70°C
CS1549D-03F-3U-TC-LD	1490nm	0°C to 70°C
CS1551D-03F-3U-TC-LD	1510nm	0°C to 70°C
CS1553D-03F-3U-TC-LD	1530nm	0°C to 70°C
CS1555D-03F-3U-TC-LD	1550nm	0°C to 70°C
CS1557D-03F-3U-TC-LD	1570nm	0°C to 70°C
CS1559D-03F-3U-TC-LD	1590nm	0°C to 70°C
CS1561D-03F-3U-TC-LD	1610nm	0°C to 70°C

DIAGNOSTICS

PARAMETER	RANGE	ACCURACY	UNIT	CALIBRATION
Module Internal Temperature	-10 to 85	±3	°C	External
Module Internal Voltage	3.0 to 3.6	±0.1	V	
Bias Current	0 to 100	±10%	mA	
TX Power	-3 to +6	±3 dB	dB	
RX Power	-32 to -8	±3 dB	dB	

ABSOLUTE MAXIMUM RATINGS

PARAMETER	SYMBOL	MIN	MAX	UNIT
Storage Temperature	T _S	-40	85	°C
Supply Voltage	V _{CC}	-0.5	4.0	V
Input Voltage	V _{IN}	-0.5	V _{CC}	V

RECOMMENDED OPERATING CONDITIONS

PARAMETER	SYMBOL	MIN	MAX	UNIT
Case Operating Temperature	T _C	0	70	°C
Supply Voltage	V _{CC}	3.1	3.5	V
Supply Current	I _{TX} + I _{RX}	-	300	mA

TRANSMITTER ELECTRO-OPTICAL CHARACTERISTICS (V_{CC} = 3.1V to 3.5V, T_C = 0°C to 70°C)

PARAMETER	SYMBOL	MIN	TYP.	MAX	UNIT	NOTES
Data Rate	B	50	155	200	Mbps	
Output Optical Power 9/125um fiber	P _{out}	0	-	+5	dBm	Average
Extinction Ratio	ER	10	-	-	dB	
Center Wavelength (1470nm)	λ _c	1464.5	-	1477.5	nm	
Center Wavelength (1490nm)		1484.5	-	1497.5	nm	
Center Wavelength (1510nm)		1504.5	-	1517.5	nm	
Center Wavelength (1530nm)		1524.5	-	1537.5	nm	
Center Wavelength (1550nm)		1544.5	-	1557.5	nm	
Center Wavelength (1570nm)		1564.5	-	1577.5	nm	
Center Wavelength (1590nm)		1584.5	-	1597.5	nm	
Center Wavelength (1610nm)		1604.5	-	1617.5	nm	
Spectral Width (-20dB)		Δλ	-	-	1	nm
Side Mode Suppression Ratio	SMSR	30	-	-	dB	
Rise/Fall Time (10~90%)	T _{r,f}	-	1	2	ns	
Max. P _{out} TX-DISABLE Asserted	P _{OFF}	-	-	-45	dBm	
Output Eye	Compliant with Telcordia GR-253-CORE Issue 3 and ITU-T recommendation G-957					
Differential Input Voltage	V _{DIFF}	0.4	-	2.0	V	

RECEIVER ELECTRO-OPTICAL CHARACTERISTICS ($V_{CC} = 3.1V$ to $3.5V$, $T_C = 0^{\circ}C$ to $70^{\circ}C$)

PARAMETER	SYMBOL	MIN	TYP.	MAX	UNIT	NOTES
Data Rate	B	50	155	200	Mbps	
Optical Input Power-Maximum	P_{IN}	0	-	-	dBm	Note 1
Receiver Input Power-Minimum (Sensitivity)	P_{IN}	-	-	-35	dBm	Note 1
Operating Center Wavelength	λ_C	1260	-	1600	nm	
Loss of Signal-Asserted	P_A	-	-	-35	dBm	
Loss of Signal-Deasserted	P_D	-45	-	-	dBm	
Loss of Signal-Hysteresis	$P_A - P_D$	1.0	-	-	dB	
Data Output Rise, Fall time (10~90%)	$T_{r,f}$	-	1	2	ns	
Differential Output Voltage	V_{DIFF}	0.5	-	1.2	V	
Receiver Loss of Signal Output Voltage-Low	RX_LOSL	0	-	0.5	V	
Receiver Loss of Signal Output Voltage-High	RX_LOSH	2.4	-	V_{CC}	V	

Note 1: The input data is at 155.52 Mbps, $2^{23}-1$ PRBS data pattern. The receiver is guaranteed to provide output data with Bit Error Rate (BER) better than or equal to 1×10^{-10} .

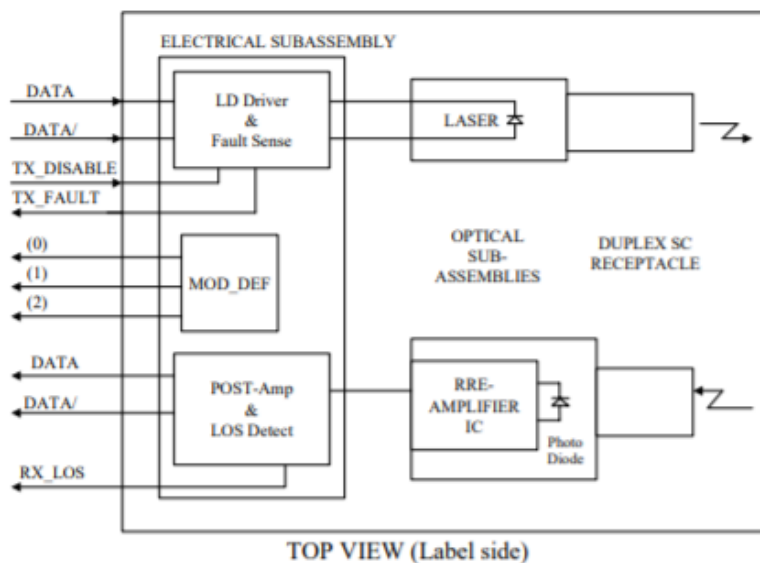
BLOCK DIAGRAM OF TRANSCEIVER

Transmitter Section - The transmitter section consists of a 1550 nm InGaAsP laser in an eye safe optical subassembly (OSA) which mates to the fiber cable. The laser OSA is driven by a LD driver IC which converts differential input LVPECL logic signals into an analog laser driving current.

TX_DISABLE - The TX_DISABLE signal is high (TTL logic "1") to turn off the laser output. The laser will turn on when TX_DISABLE is low (TTL logic "0").

Receiver Section - The receiver utilizes an InGaAs PIN photodiode mounted together with a trans-impedance preamplifier IC in an OSA. This OSA is connected to a circuit providing post-amplification quantization, and optical signal detection.

Receive Loss (RX_LOS) - The RX_LOS is high (logic "1") when there is no incoming light from the companion transceiver. This signal is normally used by the system for the diagnostic purpose. The signal is operated in TTL level.

ASSEMBLY DRAWING (unit: mm)

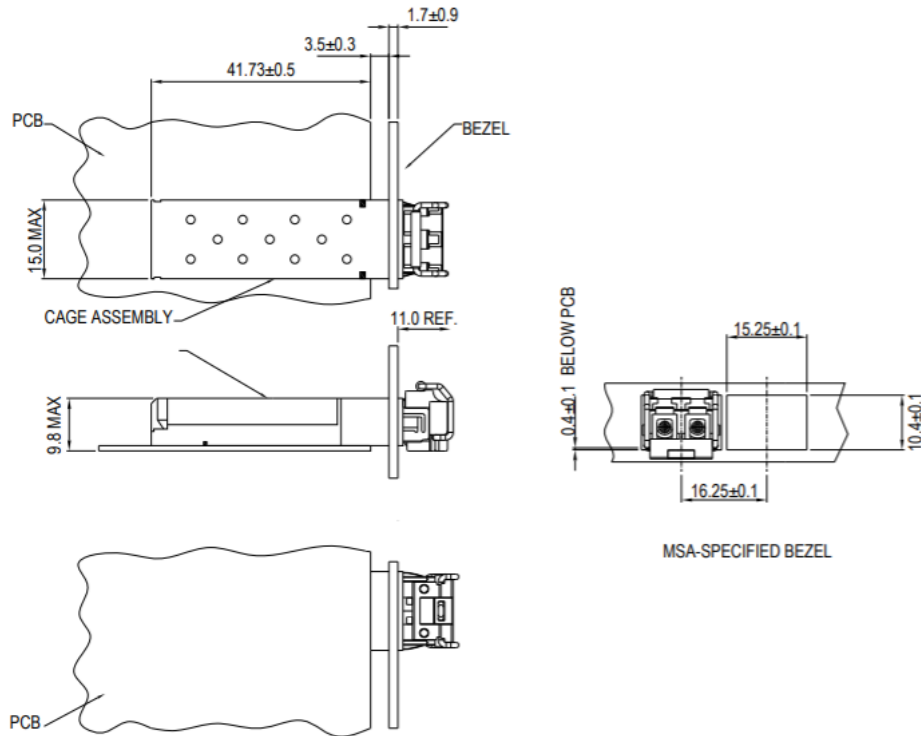

PIN ASSIGNMENT

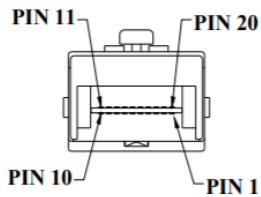

PIN	SIGNAL NAME	DESCRIPTION	PIN	SIGNAL NAME	DESCRIPTION
1	T _{GND}	Transmit Ground	11	R _{GND}	Receiver Ground
2	TX_FAULT	Transmit Fault	12	RX-	Receive Data Bar, Differential PECL, ac coupled
3	TX_DISABLE	Transmit Disable	13	RX+	Receive Data, Differential PECL, ac coupled
4	MOD_DEF (2)	SDA Serial Data Signal	14	R _{GND}	Receiver Ground
5	MOD_DEF (1)	SCL Serial Clock Signal	15	V _{CCR}	Receiver Power Supply
6	MOD_DEF (0)	TTL Low	16	V _{CCT}	Transmitter Power Supply
7	RATE SELECT	Open Circuit	17	T _{GND}	Transmitter Ground
8	RX_LOS	Receiver Loss of Signal, TTL High, open collector	18	TX+	Transmit Data, Differential PECL, ac coupled
9	R _{GND}	Receiver Ground	19	TX-	Transmit Data Bar, Differential PECL, ac coupled
10	R _{GND}	Receiver Ground	20	T _{GND}	Transmitter Ground

EYE SAFETY MARK

The single-mode transceiver is a class 1 laser product. It complies with EN 60825-1 and FDA 21 CFR 1040.10 and 1040.11. In order to meet laser safety requirements, the transceiver shall be operated within the Absolute Maximum Ratings.

Required Mark

Class 1 Laser Product
Complies with
21 CFR 1040.10 and 1040.11

[Caution] All adjustments have been done at the factory before the shipment of the devices. No maintenance and user serviceable part is required. Tampering with and modifying the performance of the device will result in voided product warranty.

ADDITIONAL NOTES

- Avoid eye or skin exposure to laser radiations.
- The device is sensitive to electro-static discharge (ESD). The device should be handled with ESD proof tools. To assemble the device on PCB, proper grounding is required to prevent ESD.
- Specifications are subject to change without notice.



Lasermate Group, Inc.
19608 Camino De Rosa
Walnut, CA 91789 USA
Tel: (909)718-0999
Fax: (909)718-0998
sales@lasermate.com
www.lasermate.com