



# 1.25Gbps TX:1310nm/RX:1550nm MMF 500m BiDi 1x9 SC Optical Transceiver

## CM3T5-24B-4S-xC-C



### DESCRIPTION

The CM3T5-24B-4S-xC-C bi-directional 1x9 transceivers are designed for use in 1.25Gbps links up to 500m over a single strand multi-mode fiber.

### FEATURES

- RoHS compliant
- Multi-mode fiber application
- Industry standard 1x9 footprint
- SC connector
- Single power supply 3.3V/5.0V
- Differential PECL inputs and outputs
- Compatible with solder and aqueous wash processes
- Class 1 laser product compliant with EN 60825-1
- Temperature: 0°C to 70°C

### APPLICATIONS

- Multi-mode core fiber backbone links up to 500m
- Gigabit Ethernet

### PRODUCT OVERVIEW

The following table lists the available part numbers, as well as the form factor, input/output, signal detect, and operating temperature of each of the part numbers.

PART NUMBER	INPUT/OUTPUT	SIGNAL DETECT	OPERATING TEMPERATURE
CM3T5-24B-4S-TC-C	AC/AC	TTL	0°C to 70°C
CM3T5-24B-4S-PC-C	DC/DC	PECL	0°C to 70°C

### ABSOLUTE MAXIMUM RATINGS

PARAMETER	SYMBOL	MIN	MAX	UNIT	NOTES
Storage Temperature	T <sub>S</sub>	-40	85	°C	
Supply Voltage	V <sub>CC</sub>	-0.5	6.0	V	
Input Voltage	V <sub>IN</sub>	-0.5	V <sub>CC</sub>	V	
Output Current	I <sub>O</sub>	-	50	mA	
Operating Current	I <sub>OP</sub>	-	400	mA	
Soldering Temperature	T <sub>SOLD</sub>	-	260	°C	10 seconds on leads

**RECOMMENDED OPERATING CONDITIONS**

PARAMETER	SYMBOL	MIN	MAX	UNIT	NOTES
Case Operating Temperature	$T_C$	0	70	°C	
Supply Voltage	$V_{CC}$	3.1	5.25	V	
Supply Current (5.0V)	$I_{TX} + I_{RX}$	-	400	mA	
Supply Current (3.3V)	$I_{TX} + I_{RX}$	-	300	mA	

**TRANSMITTER ELECTRO-OPTICAL CHARACTERISTICS ( $V_{CC} = 3.1V$  to  $5.25V$ ,  $T_C = 0^\circ C$  to  $70^\circ C$ )**

PARAMETER	SYMBOL	MIN	TYP.	MAX	UNIT	NOTES
Data Rate	B	-	1250	1300	Mbps	
Output Optical Power, 50/125 or 62.5/125um fiber	$P_{out}$	-8	-	0	dBm	Average
Extinction Ratio	ER	9	-	-	dB	
Center Wavelength	$\lambda_C$	1260	1310	1360	nm	
Spectral Width (RMS)	$\Delta\lambda$	-	-	4.0	nm	
Rise/Fall Time, 10%~90%	$T_{r,f}$	-	-	260	ps	
Output Eye	Compliant with IEEE802.3z					
Transmitter Data Input Voltage-High	$V_{IH} - V_{CC}$	-1.1	-	-0.74	V	Note 1
Transmitter Data Input Voltage-Low	$V_{IL} - V_{CC}$	-2.0	-	-1.58	V	Note 1
Transmitter Data Input Differential Voltage	$V_{DIFF}$	0.3	-	2.0	V	Note 1

**Note 1:** These inputs are compatible with 10K, 10KH and 100K ECL and PECL input.

**RECEIVER ELECTRO-OPTICAL CHARACTERISTICS ( $V_{CC} = 3.1V$  to  $5.25V$ ,  $T_C = 0^\circ C$  to  $70^\circ C$ )**

PARAMETER	SYMBOL	MIN	TYP.	MAX	UNIT	NOTES
Data Rate	B	-	1250	1300	Mbps	
Optical Input Power-Maximum	$P_{IN}$	0	-	-	dBm	$BER < 10^{-12}$
Optical Input Power-Minimum (Sensitivity)	$P_{IN}$	-	-	-18	dBm	$BER < 10^{-12}$
Operating Center Wavelength	$\lambda_C$	1500	-	1600	nm	
Return Loss	RL	-	-	-14	dB	$\lambda = 1500 \sim 1600nm$
Signal Detect-Asserted	$P_A$	-	-	-18	dBm	Average
Signal Detect-Deasserted	$P_D$	-35	-	-	dBm	Average
Signal Detect-Hysteresis	$P_A - P_D$	1.0	-	-	dB	
Signal Detect Voltage (LVPECL/PECL)-High	$V_{OH} - V_{CC}$	-1.1	-	-0.74	V	Note 1
Signal Detect Voltage (LVPECL/PECL)-Low	$V_{OL} - V_{CC}$	-2.0	-	-1.58	V	Note 1
Signal Detect Voltage (TTL)-High	$V_{OH}$	$V_{CC} - 0.8$	-	$V_{CC}$	V	
Signal Detect Voltage (TTL)-Low	$V_{OL}$	0	-	0.5	V	
Crosstalk	CRT	-	-	-45	dB	
Data Output Rise, Fall Time (20~80%)	$T_{r,f}$	-	-	0.35	ns	
Data Output Voltage-High	$V_{OH} - V_{CC}$	-1.1	-	-0.74	V	Note 1
Data Output Voltage-Low	$V_{OL} - V_{CC}$	-2.0	-	-1.58	V	Note 1
Data Output Differential Voltage	$V_{DIFF}$	0.5	-	1.8	V	

**Note 1:** These outputs are compatible with 10K, 10KH and 100K ECL and PECL input.

**DRAWING DIMENSIONS**

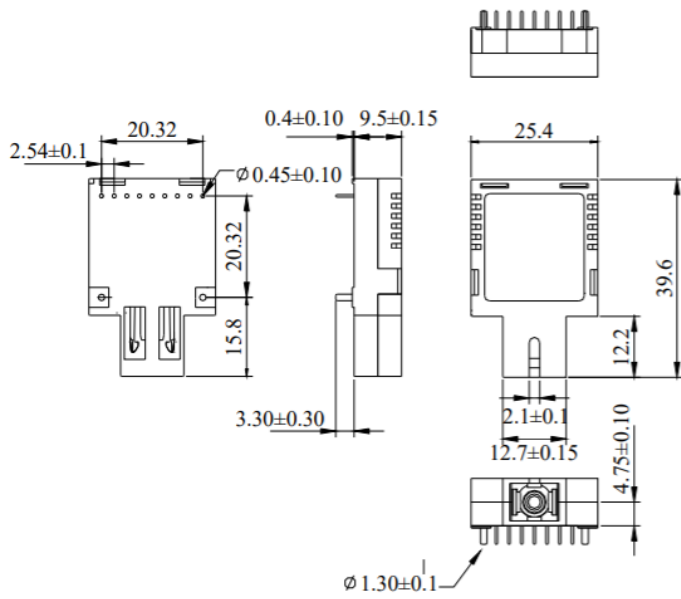

ALL DIMENSIONS ARE ±0.20mm UNLESS OTHERWISE SPECIFIED

Unit : mm

**BLOCK DIAGRAM OF TRANSCEIVER**

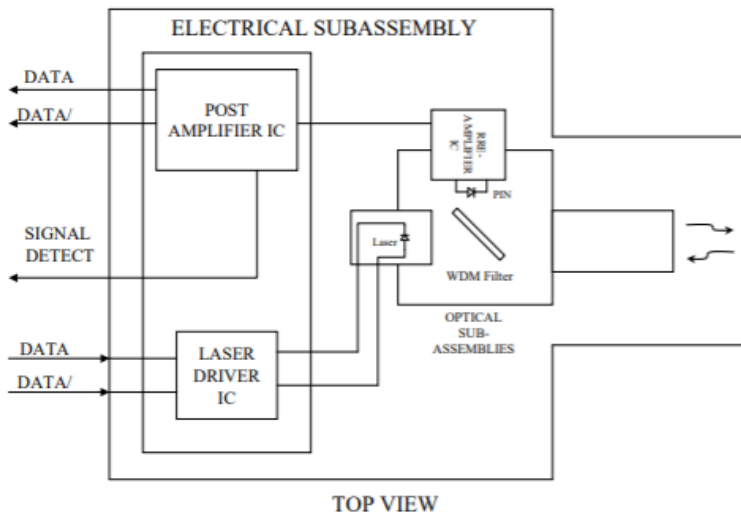

**Transmitter and Receiver Optical Sub-assembly Section** - A 1310 nm InGaAsP laser and an InGaAs PIN photodiode integrate with an WDM filter to form a bi-directional single fiber optical subassembly (OSA). The laser of OSA is driven by a LD driver IC which converts differential input LVPECL logic signals into an analog laser driving current. The photodiode of OSA is connected to a circuit providing post-amplification quantization, and optical signal detection.

**Receiver Signal Detect** - Signal Detect is a basic fiber failure indicator. This is a single-ended LVPECL output. As the input optical power is decreased, Signal Detect will switch from high to low (deassert point) somewhere between sensitivity and the no light input level. As the input optical power is increased from very low levels, Signal Detect will switch back from low to high (assert point). The assert level will be at least 1.0 dB higher than the deassert level.

CONNECTION DIAGRAM

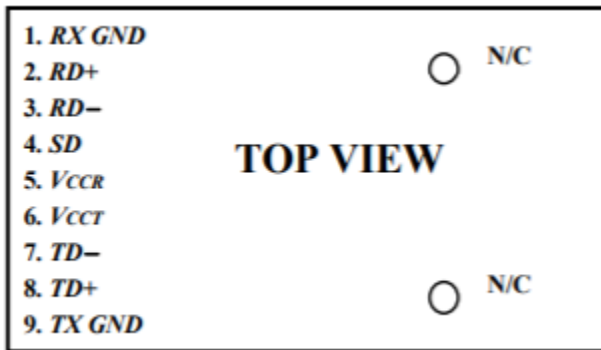

PIN	SYMBOL	DESCRIPTION
1	<i>RX GND</i>	Receiver Signal Ground, Directly connect this pin to the receiver ground plane
2	<i>RD+</i>	<i>RD+</i> is an open-emitter output circuit. Terminate this high-speed differential LVPECL output with standard LVPECL techniques at the follow-on device input pin. (See recommended circuit schematic)
3	<i>RD-</i>	<i>RD-</i> is an open-emitter output circuit. Terminate this high-speed differential LVPECL output with standard LVPECL techniques at the follow-on device input pin. (See recommended circuit schematic)
4	<i>SD</i>	Signal Detect. Normal optical input levels to the receiver result in a logic “1” output, $V_{OH}$ , asserted. Low input optical levels to the receiver result in a fault condition indicated by a logic “0” output $V_{OL}$ , deasserted. Signal Detect is a single-ended LVPECL output. <i>SD</i> can be terminated with LVPECL techniques via $50\ \Omega$ to $V_{CCR} - 2\text{ V}$ . Alternatively, <i>SD</i> can be loaded with a $180\ \Omega$ resistor to <i>RX GND</i> to conserve electrical power with small compromise to signal quality. If Signal Detect output is not used, leave it open-circuited.
5	$V_{CCR}$	Receiver Power Supply. Provide +3.3/5.0 Vdc via the recommended receiver power supply filter circuit. Locate the power supply filter circuit as close as possible to the $V_{CCR}$ pin.
6	$V_{CCT}$	Transmitter Power Supply. Provide +3.3/5.0 Vdc via the recommended transmitter power supply filter circuit. Locate the power supply filter circuit as close as possible to the $V_{CCT}$ pin.
7	<i>TD-</i>	Transmitter Data In-Bar. Terminate this high-speed differential LVPECL input with standard LVPECL techniques at the transmitter input pin. (See recommended circuit schematic)
8	<i>TD+</i>	Transmitter Data In. Terminate this high-speed differential LVPECL input with standard LVPECL techniques at the transmitter input pin. (See recommended circuit schematic)
9	<i>TX GND</i>	Transmitter Signal Ground. Directly connect this pin to the transmitter signal ground plane. Directly connect this pin to the transmitter ground plane.

RECOMMENDED CIRCUIT SCHEMATIC

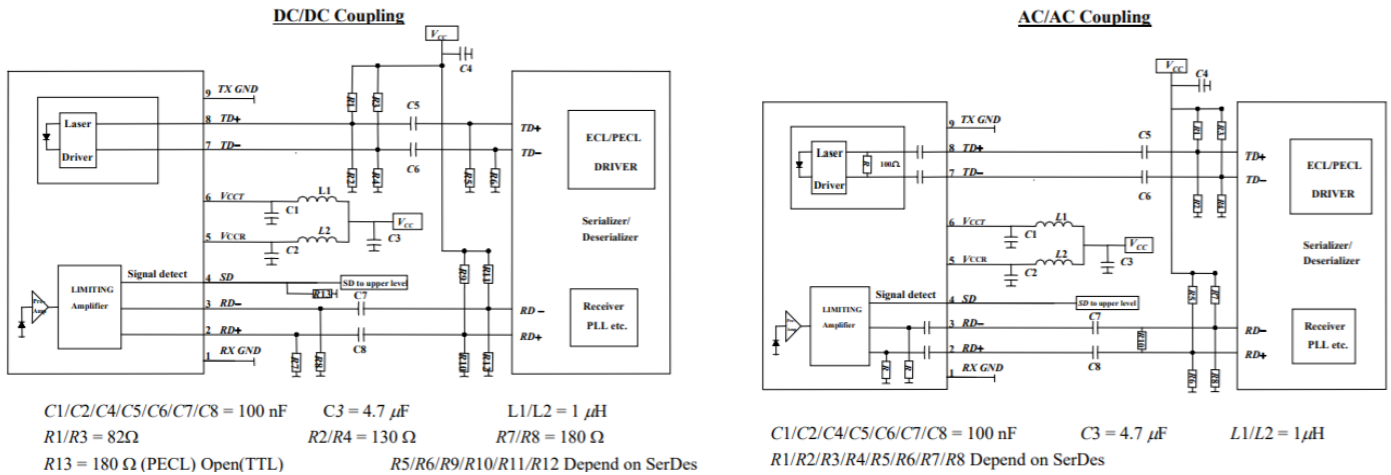

In order to get proper functionality, a recommended circuit is provided in above recommended circuit schematic. When designing the circuit interface, there are a few fundamental guidelines to follow.

- (1) The differential data lines should be treated as 50  $\Omega$  Micro strip or strip line transmission lines. This will help to minimize the parasitic inductance and capacitance effects. Locate termination at the received signal end of the transmission line. The length of these lines should be kept short and of equal length.
- (2) For the high speed signal lines, differential signals should be used, not single-ended signals, and these differential signals need to be loaded symmetrically to prevent unbalanced currents which will cause distortion in the signal.
- (3) Multi layer plane PCB is best for distribution of VCC, returning ground currents, forming transmission lines and shielding. Also, it is important to suppress noise from influencing the fiber-optic transceiver performance, especially the receiver circuit.
- (4) A separate proper power supply filter circuits shown in Figure for the transmitter and receiver sections. These filter circuits suppress VCC noise over a broad frequency range, this prevents receiver sensitivity degradation due to VCC noise.
- (5) Surface-mount components are recommended. Use ceramic bypass capacitors for the 0.1  $\mu\text{F}$  capacitors and a surface-mount coil inductor for 1  $\mu\text{H}$  inductor. Ferrite beads can be used to replace the coil inductors when using quieter VCC supplies, but a coil inductor is recommended over a ferrite bead. All power supply components need to be placed physically next to the VCC pins of the receiver and transmitter.
- (6) Use a good, uniform ground plane with a minimum number of holes to provide a low-inductance ground current return for the power supply currents.

**RECOMMENDED BOARD LAYOUT HOLE PATTERN**

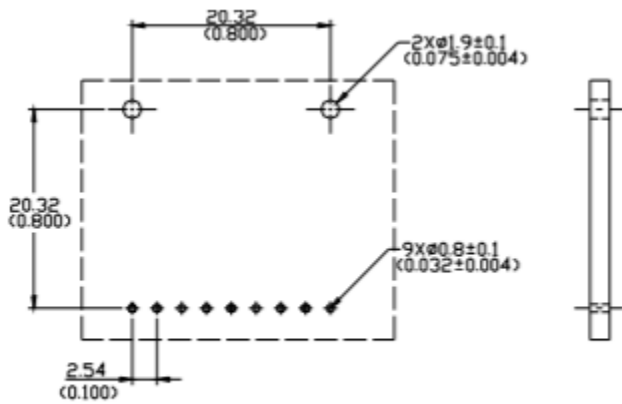

Unit : mm(inches)

This transceiver is compatible with industry standard wave or hand solder processes. After wash process, all moisture must be completely removed from the module. The transceiver is supplied with a process plug to prevent contamination during wave solder and aqueous rinse as well as during handling, shipping or storage.

Solder fluxes should be water-soluble, organic solder fluxes. Recommended cleaning and degreasing chemicals for these transceivers are alcohol's (methyl, isopropyl, isobutyl), aliphatics (hexane, heptane) and other chemicals, such as soap solution or naphtha. Do not use partially halogenated hydrocarbons for cleaning/degreasing.

**EYE SAFETY MARK**

The multi-mode transceiver is a class 1 laser product. It complies with EN 60825-1 and FDA 21 CFR 1040.10 and 1040.11. In order to meet laser safety requirements, the transceiver shall be operated within the Absolute Maximum Ratings.

**Required Mark**

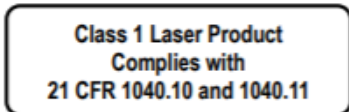

**[Caution]** All adjustments have been done at the factory before the shipment of the devices. No maintenance and user serviceable part is required. Tampering with and modifying the performance of the device will result in voided product warranty.

**ADDITIONAL NOTES**

- Avoid eye or skin exposure to laser radiations.
- The device is sensitive to electro-static discharge (ESD). The device should be handled with ESD proof tools. To assemble the device on PCB, proper grounding is required to prevent ESD.
- Specifications are subject to change without notice.



**Lasermate Group, Inc.**  
19608 Camino De Rosa  
Walnut, CA 91789 USA  
Tel: (909)718-0999  
Fax: (909)718-0998  
[sales@lasermate.com](mailto:sales@lasermate.com)  
[www.lasermate.com](http://www.lasermate.com)