



# 1550nm DFB Laser Diode TO-can with Aspherical Lens

## C15D-5A-C2G



### Description

The Lasermate C15D-5A-C2G is a 1550nm wavelength, DFB laser diode, TO-can, designed for use in telecommunication applications.

### Features

- 1550nm InGaAsP/InP MQW-DFB laser diode (LD)
- Uncooled and Hermetically sealed
- -40 to 85°C operating temperature
- High performance, high speed InGaAs monitor PIN photodiode (PD)
- Packaged in aspherical lens TO-56 type

### Applications

- SONET OC-12/OC-48
- SDH STM-4/STM-16
- Gigabit Ethernet
- Stable emitting source

### Specifications

Absolute Maximum Ratings				
Parameters	Symbol	Value	Unit	Conditions
Storage temperature	Tstg	-40~+95	°C	
Operating case temperature	Top	-40~+85	°C	
Peak optical output power	Po	15	mW	
Forward current (LD)	I <sub>FLD</sub>	120	mA	
Reverse voltage (LD)	V <sub>RLD</sub>	2	V	
Reverse current (PD)	I <sub>RPD</sub>	2	mA	
Reverse voltage (PD)	V <sub>RPD</sub>	15	V	
Soldering temperature	Stemp	260	°C	10 seconds

Electro-Optical Characteristics (CW @ T <sub>c</sub> = 25°C unless otherwise noted)						
Parameters	Symbol	Min.	Typ.	Max.	Unit	Conditions
Threshold current	I <sub>th</sub>	—	10	15	mA	CW
Operating voltage	V <sub>op</sub>	—	—	1.4	V	CW, Pop=5mW
Operating current	I <sub>op</sub>	—	—	40	mA	Pop=5mW
Slope efficiency	η	0.20	—	—	mW/mA	CW, Pop=5mW
Peak wavelength	λ <sub>p</sub>	1290	1310	1330	nm	CW, Pop
Side-mode suppression rate	SMSR	35	—	—	nm	CW, Pop, T <sub>c</sub> =-20~85°C
Fiber Coupling Power	P <sub>f</sub>	1.5	—	—	mW	CW, P <sub>o</sub> =5mW, SMF (10/125)
Focal Length	D <sub>f</sub>	7.0	7.5	8.0	mm	CW, P <sub>o</sub> =5mW, SMF (10/125)
Rise time	T <sub>r</sub>	—	80	120	ps	I <sub>b</sub> =I <sub>th</sub> , 20%~80%
Fall time	T <sub>f</sub>	—	100	150	ps	I <sub>b</sub> =I <sub>th</sub> , 20%~80%
Monitor current	I <sub>m</sub>	80	—	1000	uA	Pop, V <sub>rp</sub> =5V
Monitor dark current	I <sub>d</sub>	—	—	100	nA	V <sub>rp</sub> = 5V
Monitor capacitance	C	—	—	15	pF	V <sub>rp</sub> = 5V, f=1MHZ

**Outline Dimensions (unit: mm)**

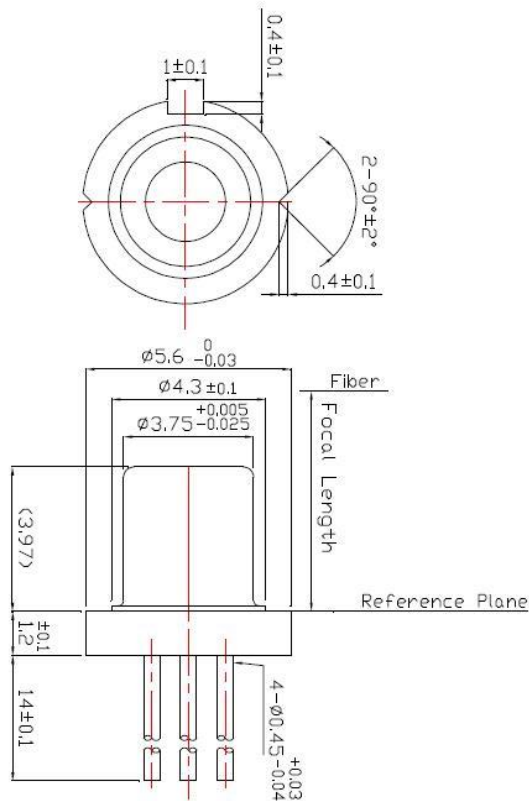

**Pin Assignment**

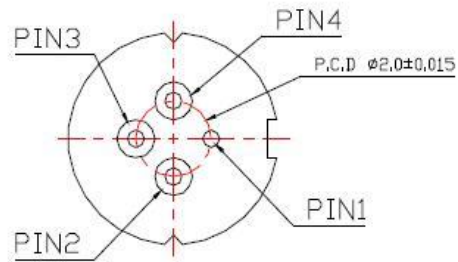

Pin Number	Function
1	Case
2	LD Cathode
3	PD Anode
4	LD Anode, PD Cathode

**Additional Notes**

- Avoid eye or skin exposure to laser radiations.
- The device is sensitive to electro-static discharge (ESD). The device should be handled with ESD proof tools. To assemble the device on PCB, proper grounding is required to prevent ESD.
- Specifications are subject to change without notice.



**Lasermate Group, Inc.**  
 19608 Camino De Rosa  
 Walnut, CA 91789 USA  
 Tel: (909)718-0999  
 Fax: (909)718-0998  
[sales@lasermate.com](mailto:sales@lasermate.com)  
[www.lasermate.com](http://www.lasermate.com)